

PullRite ^{years} 40

CELEBRATING

ISR SERIES Mounting Kits

Our Mounting Kits are better than the “other guy’s” and are constructed from high quality materials made here in the USA. Custom and Universal brackets install center of axle, Custom Brackets require less drilling and install faster, and our Universal kits fit more trucks without ordering extra kits.



NOTE: In order to determine the total tow capacity of a system, you must consider the weight ratings of each component in that system. This includes, but may not be limited to, the rating of the tow vehicle, the fifth wheel hitch, and the hitch's mounting system. Actual tow capacity of the system will be equal to the lowest rated component.

		Universal	Universal HEAVY DUTY	Custom	Custom HEAVY DUTY	SuperRail
		PullRite#	PullRite#	PullRite#	PullRite#	PullRite#
CHEVY / GMC						
2016-2019	2500 & 3500 (NO DRILL) (designed for easier install)			2762		
2011-2019	2500 & 3500 (NO DRILL)			2724	2226	2328
2001-2016	2500 & 3500 HD	2720	2220			
1999-2010	2500 & 3500 HD			2734	2224	2326
2019	1500 (New body style)			2768		
2007-2019	1500 (6-1/2' bed, old body style)	2720		2730		
DODGE						
2013-2019	3500 (NO DRILL)			2742		
2014-2019	2500 (NO DRILL)			2746		2336
2013	2500 (NO DRILL)			2740		
2003-2012	2500 & 3500 (*NO DRILL) (does not fit 3500 w/ overload springs)	2720	2220	2736*	2230*	2330*
2016-2019	1500 (does not fit w/ air bags)			2764		
2009-2015	1500 (does not fit w/ air bags)			2728		
FORD						
2017-2019	F250 & F350 (NO DRILL)			2766		2332
2011-2016	F250 & F350 (NO DRILL)			2738	2228	2324
1999-2016	F250 & F350	2720	2220			2324
1999-2010	F250 & F350			2726	2228	
2015-2019	F150 (NO DRILL)			2760		
2004-2014	F150 (NO DRILL)			2732		
TOYOTA						
2007-2019	Tundra (fits all bed lengths)			2748		

ALL THE ABOVE KITS FIT LONG OR SHORT BED TRUCKS WITH ANY BRAND ISR HITCH. HD KITS ARE RECOMMENDED FOR HITCHES RATED FOR MORE THAN 20K

UNIVERSAL KITS include “L” Brackets, ISR Base Rails & Hardware. Heavy Duty kits include ISR HD Base Rails & Hardware

CUSTOM KITS include Custom Mounting Brackets, ISR Base Rails, & Hardware. Heavy Duty kits include ISR HD Base Rails, & Hardware

SUPERRAIL KITS featuring Clean Bed Technology include totally removable SuperRails & Posts, Mounting Brackets & Hardware for a clean truck bed!

PullRite

CELEBRATING **40** years



TRADITIONAL SERIES Mounting Kits



#4100 - 16K (left)
#4400 - 20K (right)

Universal Mounting Kits
only applicable for
#4100 and #4400
SuperGlide models



#3100 - 12K

SUPER SHORT BED SOLUTION

#3100 SuperRail Mounting Kits
only applicable to the #3100
Traditional Series SuperGlide

NOTE: In order to determine the total tow capacity of a system, you must consider the weight ratings of each component in that system. This includes, but may not be limited to, the rating of the tow vehicle, the fifth wheel hitch, and the hitch's mounting system. Actual tow capacity of the system will be equal to the lowest rated component.

Universal	SuperRail	#3100 SuperRail
PullRite#	PullRite#	PullRite#

CHEVY / GMC		Universal	SuperRail	#3100 SuperRail
Year	Model / Bed	PullRite#	PullRite#	PullRite#
2011-2019	2500 & 3500 (NO DRILL)		4428	
1999-2010	2500 & 3500	3340	3345	
2007-2019	1500 (6-1/2' bed, old body style)		4423	
1999-2007	1500 (6-1/2' bed, except 2007 mid-year body change)	3340	3345	
2019	1500 (5'8", new body style)			3124*
2007-2019	1500 (5'8" bed, old body style only)			3117*
2004-2007	1500 (5'8" Bed, except 2007 current body style)			3114*
DODGE		Universal	SuperRail	#3100 SuperRail
Year	Model / Bed	PullRite#	PullRite#	PullRite#
2013	2500 (NO DRILL)		4440	
2003-2012	2500 & 3500 (NO DRILL)		3349	
2009-2019	1500 (5'7" & 6-1/2' bed. Old body style)			3122*
2002-2008	1500 (NO DRILL)		3349	
1995-2002	(except '02 1500)	3340	3346	
FORD		Universal	SuperRail	#3100 SuperRail
Year	Model / Bed	PullRite#	PullRite#	PullRite#
1999-2016	F250 & F350	3340	4426	
2015-2019	F-150 (5'6" bed)			3123*
2004-2014	F-150 (6-1/2' bed)		3361	
1997-2003	F-150 (6-1/2' bed)	3340	3342	
2009-2014	F-150 (5'7" bed)			3119*
2004-2008	SuperCrew F-150 (5'6" bed)			3113*
2001-2003	SuperCrew F-150 (5'6" bed)			3111*
TOYOTA		Universal	SuperRail	#3100 SuperRail
Year	Model / Bed	PullRite#	PullRite#	PullRite#
2007-2019	Tundra (Double Cab Only, 6-1/2' bed, Universal Rails with Custom Mounting Brackets)	4421		
2001-2006	Tundra (Standard Extra Cab)			3112*
2007-2019	Tundra (Crew Max and 5'8" bed only)			3118*

ALL THE ABOVE KITS FIT 6-1/2' SHORT BED TRUCKS, EXCEPT #3100 SUPERGLIDE WHICH IS DESIGNED FOR SUPER SHORT (5-1/2') BEDS ONLY.
* TO DETERMINE CORRECT #3100 SUPERGLIDE TRUCK/TRAILER COMBINATIONS, GO ONLINE TO PULLRITE.COM/3100_HIW.

UNIVERSAL KITS include "bolt to the bed" Baseraills, Universal "L" Brackets and Hardware

SUPERRAIL KITS featuring *Clean Bed Technology* include totally removable SuperRails & Posts, Mounting Brackets & Hardware for a clean truck bed!

#3100 SUPERRAIL KITS featuring *Clean Bed Technology* include totally removable SuperRails & Posts, Mounting Brackets & Hardware for a clean truck bed!

Super Lite

PullRite's line of SuperLite and our NEW Super 5th single point attachment hitches combine the lightweight design of a SuperLite hitch base with the innovation of an underbed gooseneck mounting system.

Lightweight and stronger than aluminum, the base made from high grade American steel. Mounts directly to your truck's OE puck mounting system or any aftermarket underbed gooseneck with a 2-5/16" ball.

Bed Saver Rails prevent damage to your truck bed through movement of the hitch base because they act independently to insulate your bed from hitch movement. Multiple height adjustments for bed side clearance. All models SAE J2638 tested. **MADE IN USA.**



#2600 - 20K

(SuperLite King Pin Adapter and Handle included)

Super 5th



#3700 - 16K

#3800 - 20K (coming soon)

#3900 - 24K

NOTE: In order to determine the total tow capacity of a system, you must consider the weight ratings of each component in that system. Actual tow capacity of the system will be equal to the lowest rated component, including the vehicle tow rating.

Mounting Hardware

CHEVY / GMC		
2016-2019	2500 & 3500, long and short bed trucks w/ OE tow package	4437
2008-2019	2500 & 3500, long and short bed trucks w/ aftermarket 2-5/16" gooseneck ball	SEE GOOSENECK MANUFACTURER
DODGE		
2008-2019	2500 & 3500, long and short bed trucks w/ OE tow package	4437
2013-2019	2500 & 3500, long and short bed trucks w/ aftermarket 2-5/16" gooseneck ball	SEE GOOSENECK MANUFACTURER
FORD		
2008-2019	F250 & F350, long and short bed trucks w/ OE tow package	4437
2010-2019	F250 & F350, long and short bed trucks w/ aftermarket 2-5/16" gooseneck ball	SEE GOOSENECK MANUFACTURER

GOOSENECK PLATES & ADAPTERS

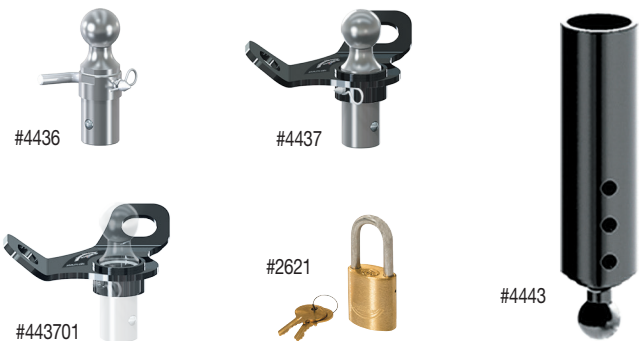

SINGLE POINT ACCESSORIES

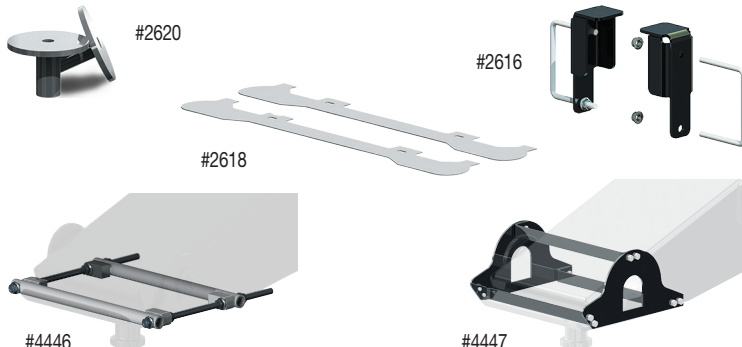

PART#	PRODUCT DESCRIPTION
4436	30K OE CAM-ACTION BALL W/ PIN & CLIP
4437	30K OE CAM-ACTION BALL W/ PLATE
443701	OE CHAIN PLATE ONLY
2621	OE GOOSENECK BALL LOCK KIT
4443	30K SUPERLITE HORSE TRAILER / GOOSENECK ADAPTER

PART#	PRODUCT DESCRIPTION
2620	CHEVY/GMC PUCK PLUG SET (4 PCS)
2616	CHEVY/GMC BED SUPPORT BRACKET KIT
2618	BED SAVER PLASTIC SLIDE SET
4446	ROTA-FLEX PIN BOX ISOLATOR
4447	ROTA-FLEX PIN BOX ISOLATOR

OE PUCK SERIES HITCHES & Accessories

SuperGlide is now available in our expanding OE Puck Series line of fifth wheel hitches, as well as two new Super 5th's for Chevy/GMC trucks! These direct attachment hitches mount directly to your truck's OE mounting points...NO ADAPTER RAILS NEEDED!

The mounting post assemblies on each model are completely removable for easier removal and installation of the hitch. Simply unpin handles, rotate 1/4 turn outward and lift the hitch out of the bed. NO TOOLS NEEDED! Premium hardware, like the use of castle nuts, allow for finer adjustments of the OE puck handles for ease of installation and fit! All models SAE J2638 tested. MADE IN USA.

NEW!

OE PUCK SERIES SUPERGLIDE



PART#	PRODUCT DESCRIPTION
2714	16K OE SERIES SUPERGLIDE FOR FORD
2914	18K OE SERIES SUPERGLIDE FOR FORD
2715	16K OE SERIES SUPERGLIDE FOR CHEVY/GMC
2915	18K OE SERIES SUPERGLIDE FOR CHEVY/GMC
2315	24K OE SERIES SUPERGLIDE FOR DODGE

OE PUCK SERIES SUPER 5TH



PART#	PRODUCT DESCRIPTION
1300	18K OE SERIES SUPER 5 TH FOR FORD
1400	25K OE SERIES SUPER 5 TH FOR FORD
1500	18K OE SERIES SUPER 5 TH FOR CHEVY/GMC
1600	25K OE SEREIS SUPER 5 TH FOR CHEVY GMC

NEW!

NOTE: In order to determine the total tow capacity of a system, you must consider the weight ratings of each component in that system. This includes, but may not be limited to, the rating of the tow vehicle, the fifth wheel hitch, and the hitch's mounting system. Actual tow capacity of the system will be equal to the lowest rated component.

ISR RAIL ADAPTERS PullRite#	OE PUCK SERIES SUPER 5 th	OE PUCK SERIES SUPERGLIDE
--------------------------------	---	------------------------------

CHEVY / GMC				
2016-2019	2500 & 3500 (not compatible with #2300 HD SuperGlide)	4444	1500/1600	2715/2915
DODGE				
2014-2019	2500 & 3500	4439		2315
2013	3500	4439		2315
FORD				
2010-2019	F250, F350 & F450	4442	1300/1400	2714/2914

ISR RAIL ADAPTER KITS featuring *Clean Bed Technology* include totally removable SuperRails, Posts & Hardware for a clean truck bed!

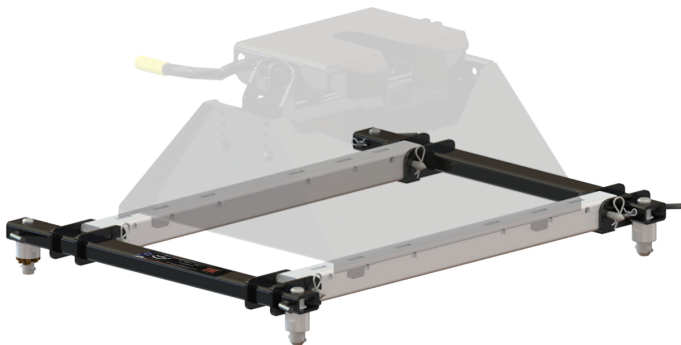

OE SERIES ISR RAIL ADAPTERS

Converts any ISR Series, or any industry standard type, hitch into an OE Puck Mounted system. Quick install/removal with pins and clips, NO TOOLS REQUIRED, leaves you with a clean bed. SAE J2638 tested.

PART#	PRODUCT DESCRIPTION
4439	OE SERIES RAIL ADAPTER FOR DODGE (LEFT)
4442	OE SERIES RAIL ADAPTER FOR FORD
4444	OE SERIES RAIL ADAPTER FOR CHEVY/GMC

Capture Plates are a required component of the SuperGlide hitch system. When the trailer is hooked up to the hitch, the Capture Plate's wedge isolates the king pin from turning in the fifth wheel plate, causing the Cam Assembly to activate and allowing the SuperGlide to move as turns are being made. Most applications slip over the king pin and are held in place by a set screw. Follow the instructions below to determine your correct Capture Plate.

- 1) Find the manufacturer's name and model number located on your pin box.
- 2) Then find the Quick Connect part number that corresponds to that information.
- 3) To ensure correct fit, make the necessary A, B and C measurements:

- A: Measure the king pin plate from side-to-side. This is the most important measurement. Be sure that this measurement is no more than 1/16" less than the measurement listed in the column below.
- B: Measure from the leading edge of the king pin to the leading edge of the king pin plate.
- C: Measure from the rear edge to the leading edge of the king pin plate

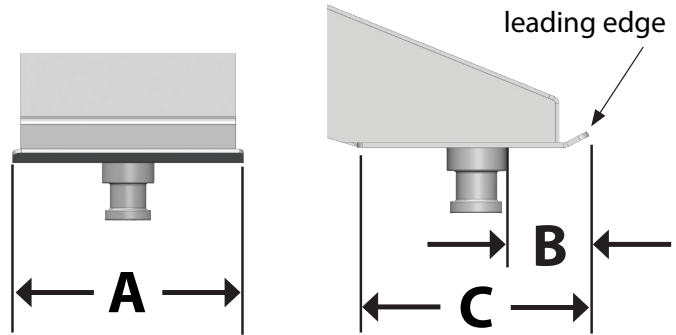

Quick Connect CAPTURE PLATE

Sizing Chart (recommended)

King Pin Box Manufacturer	MFR#	King Pin Box Model #	"A"	"B"	"C"
5th Airborne (medium)	331709	Most Models	10-1/2"	6-7/8"	14-1/4"
5th Airborne	331759	Most Models	12"	7-7/8"	19-7/8"
Demco (not Universal)	331750	Most Models	10-3/4"	5"	11-7/8"
Demco (not Universal)	331751	Most Models	11-1/4"	5-1/8"	12-1/16"
Dexter	331731	Most Models	12"	5-9/16"	12-1/4"
Fabex	331720	500's, 765, 770*	13-1/2"	3-1/4"	9-1/4"
Fabex	331706	Most Models	12"	4-5/8"	11-3/8"
Leland	331730	Most Models	14"	5-1/2"	12-1/4"
Lippert (long)	331704	1621*	12-3/4"	3-3/8"	8-7/8"
Lippert (long)	331711	1621 HD*	12-3/4"	4"	8-7/8"
Lippert (long)	331705	1621*	13-1/4"	3-3/8"	8-7/8"
Lippert (medium)	331705	1116*	13-1/4"	3-1/2"	9-3/16"
Lippert (long)	331705	1716*	13-1/4"	3-1/4"	8-7/8"
Lippert	331710	0719**	12-3/4"	6-3/8"	12-1/4"
Lippert Rhino Box	331723	Rhino	7-3/8"	2-5/16"	7-3/4"
MOR/ryde (not Universal or Multi-fit)	331707	Rubber Cushion	13-1/2"	7-5/16"	17-1/2"
MOR/ryde (not Universal or Multi-fit)	331708	Standard	12-1/2"	4-1/8"	8-7/8"
Trailair Rota-Flex / Road Armor (not Universal or Multi-fit)	331756	Most Models	13-3/8"	5-3/8"	11-7/16"
Trailair Rota-Flex / Road Armor (not Universal or Multi-fit)	331760	Most Models	13-5/8"	5"	11-7/16"
Trailair FlexAir	331761	Most Models	13-1/4"	6-1/8"	12-3/4"
Trailair Tri Glide Airbag/Shock Pin Box	331757	Tri Glide Only	12-3/4"	5-15/16"	ALL
Trailair Airbag/Shock Pin Box	331758	Most Models	13-3/8"	7-3/8"	13-1/2"
Reese Revolution	331721	10K Pin Box	10-1/2"	4-1/4"	11"
Reese Revolution (*for 16K with spacers)	331722	16K or 21K Pin Box	13" or *12-1/2"	4-1/4"	11-3/4"
Multi-fit and Universal Capture Plates					
Multi-fit Capture Plate	3365	* Fits the indicated pin boxes above	12-3/4" through 13-1/2" & 14"	2-9/16" - 4"	ALL
Multi-fit Capture Plate	3366	** Fits the indicated pin boxes above	12, 12-1/4", 12-3/4"	5-3/16" - 6-5/8"	ALL
Universal Capture Plate Kit	3317	INCLUDES: Universal Capture Plate, Fore & Aft Plate Extensions, Knee Braces, & Hardware			