



Gooseneck **OWNER'S MANUAL**

for OE Puck or Single Point Underbed Gooseneck Systems



#4437 30K OE Series Gooseneck Ball w/ Plate

(#4436 30K OE Series Gooseneck, Pin & Clip only)

Gross Trailer Weight (Maximum)	30,000 lbs.
Vertical Load Weight (Max. Pin Weight)	7,500 lbs.

THE FOLLOWING INSTRUCTIONS PROVIDE VALUABLE INFORMATION REGARDING THE FUNCTION AND PROPER USE OF THE OE SERIES FIFTH WHEEL TOWING SYSTEM. PATENT PENDING.

YOU MUST COMPLETELY READ THE INSTRUCTIONS WITHIN THIS MANUAL PRIOR TO OPERATING THE HITCH TO PREVENT UNNECESSARY DAMAGE TO THE HITCH, VEHICLE, OR TRAILER.

ALL PULLRITE HITCHES TESTED TO SAE J2638 STANDARDS • MADE IN THE USA

FOR MORE INFORMATION, PLEASE CALL PULLRITE AT (800) 443-2307.

TABLE OF CONTENTS

SYSTEM WEIGHT RATING vs. COMPONENT WEIGHT RATING.....	3
LUBRICATION	3
GOOSENECK BALL & HITCH PIN.....	3
ANNUAL MAINTENANCE.....	3
HITCHING	4
SAFETY CHECKS	4
GOOSENECK BALL INSTALLATION	5
PARTS SECTION	6
ILLUSTRATION — EXPLODED VIEW	6
PARTS LIST	7

SYSTEM WEIGHT RATING vs. COMPONENT WEIGHT RATING

A towing system includes each vehicle and component involved in towing. Each item in your towing system has a capacity or weight rating. Your trailer has a Gross Vehicle Weight Rating, or GVWR. Your truck has a tow capacity, payload capacity, and possibly more. In addition, your gooseneck hitch has a weight rating. The 30,000 lb. weight rating must be at, or above the GVWR of your trailer for you to tow safely. In addition, if your truck can tow larger loads (has a larger capacity) than the rating of your hitch, your system is only safe to tow loads at the lower rating, that of the hitch.

Your gooseneck puck system also has a weight rating, just like your OE Gooseneck Ball. Many times, these ratings are designed to match one another, but this is not always the case. Your mounting kit may be higher rated than your gooseneck hitch, but it also could be lower depending on the components involved. **The lowest rating of any one component in the system becomes the rating of the entire system.** If your mounting kit is SAE rated for 18,000 lbs., and your hitch is SAE rated at 24,000 lbs., the weight rating of the entire system will not be above 18,000 lbs. Other components in the system could lower the actual system rating further.

It is the end users responsibility to ensure a safe towing experience. To this end, it is your responsibility to ensure that the truck, trailer, hitching components, and all other items involved are rated or have a capacity sufficient for the loads involved.

(insert that WR SHOULD BE TESTED TO THE SAME STANDARDS...THE SAME AS THE HITCH TESTING, SAE J2638...THEN EXPLAIN WHAT SAE J IS...THIS IS A STANDARD OUR INDUSTRY USES FOR RATINGS),

LUBRICATION

DO NOT OPERATE HITCH UNTIL YOU READ THIS SECTION!

The internal mechanism of the Gooseneck Ball should be lubricated with a light lubricant such as WD-40 or 3-in-1 oil, from bottom side of the Gooseneck Ball as needed. Be sure the gooseneck ball is free of dirt and old grease buildup. Lock and unlock the Gooseneck Ball repeatedly so that the lubricant will spread among the moving parts that may not have otherwise been covered sufficiently.

GOOSENECK BALL & HITCH PIN

Be sure the trailer's gooseneck coupler is clean and free from rust. A light coating of axle grease or other similar lubricant should be used on the Gooseneck Ball. Inspect and lubricate the Gooseneck Ball monthly with axle grease when heavily used. A light coating of lubricant on the hitch pins will help you install and reinstall them easily.

ANNUAL MAINTENANCE

Inspect all mounting bracket and gooseneck hardware, that it is securely fastened. Inspect all mounting bolts for tightness and general condition. The Gooseneck Ball should be removed and inspected, checking all moving parts for wear—clean as directed above. We recommend a degrease tank treatment annually or as needed. When storing your Gooseneck Ball, you should be sure that the Gooseneck Ball parts are lubricated to retard the formation of rust. Cover the entire assembly to prevent accumulation of dirt, grime, or rust.

WARNINGS

1. If you are a first time RV'er, we encourage you to go online and educate yourself on towing as it has its own risks. Read [The Trailer Handbook: A Guide to Understanding Trailer and Towing Safety](http://www.natm.com) at their website at www.natm.com. Also be sure to read your trailer's Owners Manual as well as this Manual in its entirety.
2. Failure to use these products for their intended use, and failure to match the kit to the correct application may cause damage and will void the warranty.
3. Be sure you are towing a gooseneck trailer with a 2-5/16" coupler. Failure to do so may result in damage.
4. Most states require safety chains to be used. Make sure that the trailer safety chains are properly connected to the chain plate at the gooseneck ball and trailer.
5. Connect all trailer lighting and check that it is hooked up properly and is in good working order.
6. Check your coupler or trailer's owners manual for correct operation and safety checks. Failure to perform safety checks may result in damages to truck, trailer and other components and will void the warranty.
7. Never exceed the maximum weight ratings of the coupler, hitch/gooseneck and truck and trailer. Exceeding these ratings may result in damage and will void the warranty.
8. Modifications to this product in any manner outside of the guidelines contained within these instructions are prohibited and will void the warranty.
9. Check vehicle, Gooseneck Ball and gooseneck coupler for signs of wear or damage. Ensure that the gooseneck coupler opens, closes, and the handle springs close when released. (Always replace bent, broken, or worn parts before using this product.)

GOOSENECK BALL INSTALLATION

NOTE: The OE Series Gooseneck Ball can only be installed in vehicles equipped with an OE Puck/Single Point Underbed gooseneck system (not compatible with aftermarket underbed gooseneck systems)

1. Check that the OE Gooseneck Ball is in the unlocked position. To do this, hold the Gooseneck Ball Post {F} and rotate Ball counter-clockwise. You will notice the ball bearing is in a recessed position with the wall of the Gooseneck Post and the “flats” on the Post are not aligned with one another...see Figure 1. Place the assembly into the center puck (Figure 2)
2. Lock the Gooseneck Ball into the center puck by holding the Gooseneck Ball Post and rotating the Ball clockwise (Figure 3). The “flats” on the Gooseneck Ball and Post should now be aligned.

CHAIN PLATE INSTALLATION (optional)

If a Chain Plate {B} is required in your area, follow these steps for installation.

1. Install the OE Gooseneck Ball assembly following Steps 1 & 2 above.
2. Slip the Chain Plate over the installed OE Gooseneck Ball Assembly. The truck's puck plastic trim ring may have to be removed for proper fit.
3. Install the Hitch Pin {D} through the Gooseneck Ball Post and secure it with the Pin Clip {E} (see Figure 4).

To deter theft, purchase the PullRite Padlock and Key (#98410574) which replaces the Hitch Pin Clip {E}.

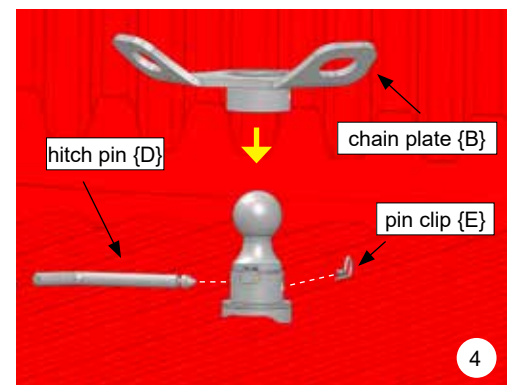
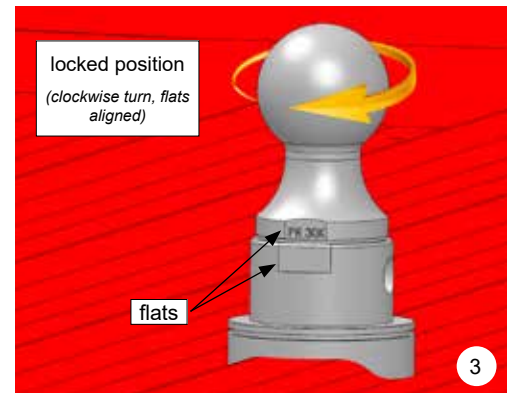
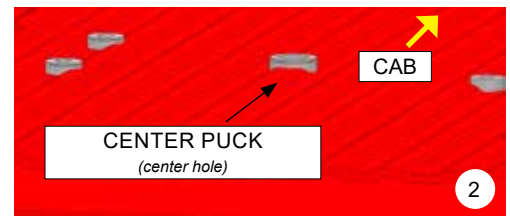
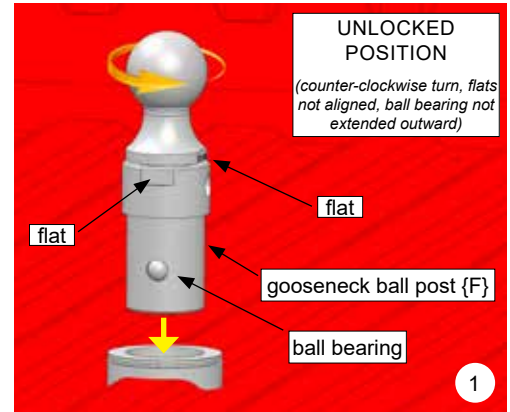
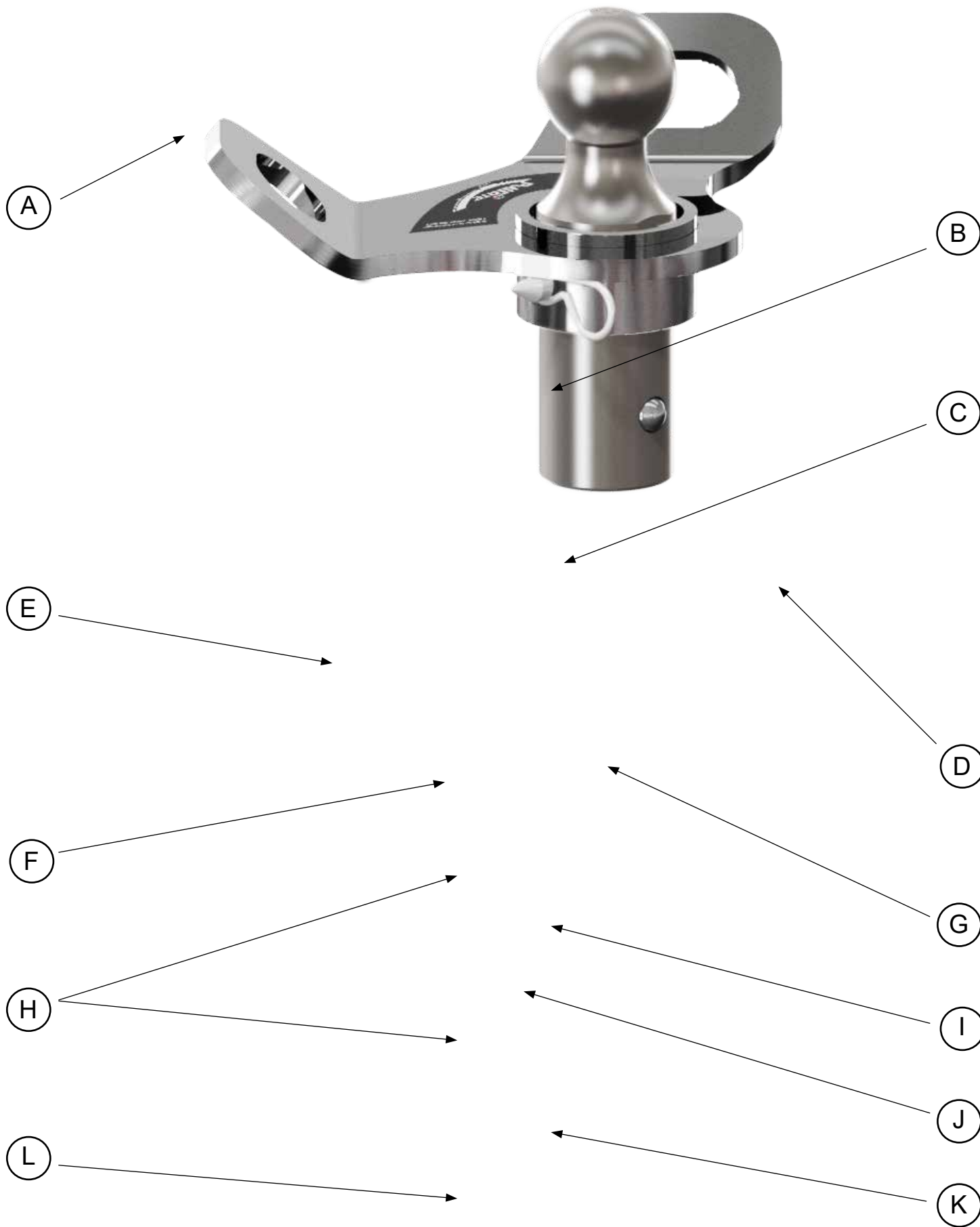

ILLUSTRATION — EXPLODED VIEW



PARTS LIST

ITEM	DESCRIPTION	PART NO.	QTY.	MATERIAL
A	CHAIN PLATE	443701	1	ZINC PLATED STEEL <i>(included in #4437 kits)</i>
B	OE GOOSENECK BALL ASSEMBLY	443602	1	ZINC PLATED STEEL
C	BALL WASHER	44360102	1	NYLON WASHER
D	HITCH PIN	010019	1	5/8" X 6" MANUFACTURED HITCH PIN
E	PIN CLIP	98410143	1	#9 PIN CLIP
F	OE GOOSENECK BALL POST	44360301	1	ZINC PLATED STEEL
G	BALL BEARING	98410569	2	STAINLESS STEEL BALL BEARING
H	CAM WASHER	44350101	2	NYLON CAM WASHER
I	CAM LAMINATION PLATES	44350102	5	STAINLESS STEEL CAM ACTION PLATES
J	ROLL SPRING PINS	98410573	2	3/16" X 1-1/8" SLOTTED SPRING PIN (ROLL PIN) ZINC PLATED
K	CAM BOTTOM PLATE	44350103	1	ZINC PLATED STEEL
L	SOCKET HEAD CAP SCREW	98410235	2	1/4"-20 X 1-3/8" SOCKET HEX HEAD CAP SCREW ZINC PLATED GRD 5

5 YEAR LIMITED WARRANTY

PULLIAM ENTERPRISES, INC. hereinafter referred to as "PULLIAM", warrants to the first retail owner only, this PullRite towing system to be free from defects in materials and workmanship for a period of five (5) years or 31,068 miles (50,000 km) after the installation on purchaser's vehicle, whichever occurs first.

To validate this warranty, the first retail owner must mail the provided warranty card to PULLIAM, or register online at www.pullrite.com, within ten (10) days after installation of said towing system on his vehicle.

The owner is responsible for all normal and preventative maintenance described in the Owner's Manual.

If any defect occurs which the owner believes is covered by this warranty within said five (5) year period, the owner shall contact PULLIAM immediately, either in writing or by telephone call, Attention Customer Service Department. The owner will be instructed to return the hitch at his expense either to an authorized PullRite dealer or to PULLIAM to repair or replace any parts necessary to correct defects in material or workmanship.

Repair or replacement shall be at the sole option of PULLIAM and shall be completed by or on behalf of PULLIAM free of charge for materials and labor.

This warranty gives you specific legal rights, and you may also have other right's which vary from state to state.

THIS WARRANTY SPECIFICALLY *EXCLUDES* EACH OF THE FOLLOWING:

1. Defects in the product resulting from misuse, neglect, accident, loading beyond the vehicle's capacity, failure to comply with instructions contained in the Owner's Manual or unauthorized repairs, replacements, alterations or modifications. "Unauthorized repair, replacements, alterations" are those made without PULLIAM'S prior knowledge and consent.
2. Any incidental or consequential damage including, but not limited to, loss of use of the vehicle, towing charges, vehicle rental, loss of time, inconvenience, travel, gasoline, lodging and telephone expenses, loss of revenue and damages on account of personal injury and property damage. (Some states do not allow the exclusion or limitation of incidental or consequential damages, so these limitations may not apply to you).
3. Repairs or replacements of defects in any PullRite towing system, or part thereof, installed on any vehicle which has been rented, leased or used for any commercial purpose.
4. Any representation, warranty of undertaking made by any dealer or third party beyond the scope of the warranty herein expressed.
5. Any problem resulting in normal deterioration due to wear or exposure.

TO THE EXTENT PERMITTED BY LAW, IMPLIED WARRANTIES OF MERCHANTABILITY AND FITNESS FOR A PARTICULAR PURPOSE ARE LIMITED IN DURATION TO FIVE YEARS FROM THE DATE OF INSTALLATION ON THE FIRST OWNER'S VEHICLE. (SOME STATES, HOWEVER, DO NOT ALLOW LIMITATIONS AS TO DURATION OF IMPLIED WARRANTY, SO THOSE LIMITATIONS MAY NOT APPLY TO YOU)



Product Warranty Registration

As an owner of a PullRite product, you must register your product to be considered for warranty coverage. See Owners Manual for further details.

Please note, that you can also register online at www.pullrite.com/warranty.htm.

Name: _____

Address: _____

City: _____ State: _____ Zip: _____

Email Address: _____

Phone (optional): _____

Purchase Price: _____ Date of Purchase: _____

Dealer's Name: _____

Dealer's Address: _____

Dealer's City: _____ Dealer's State: _____ Dealer's Zip: _____

Dealer's Phone: _____

Model Purchased: _____

Vehicle Make: _____ Vehicle Model: _____ Vehicle Year: _____

Vehicle Year: _____ Vehicle Cab Style: _____ Vehicle Bed Length: _____

Did you receive an Owners Manual from the Dealer? Yes / No

What influenced you to buy your hitch? _____

Comments:



MANUFACTURED BY:

PULLIAM ENTERPRISES, INC.
13790 East Jefferson Blvd.
Mishawaka, IN 46545
(574) 259-1520 • (800) 443-2307
info@pullrite.com • www.pullrite.com