



OWNER'S MANUAL



#4700 #4800 #4900

OEX Series Fifth Wheel Hitch (25K)

#4700 for 2010 to present model Ford trucks

#4800 for 2013 to present model Ram trucks

#4900 for 2020 to present model GM trucks

Gross Trailer Weight (Maximum) 25,000 lbs.

Vertical Load Weight (Max. Pin Weight)...6,000 lbs.

The following instructions provide valuable information regarding the function and proper use of the Super 5th OEX Towing System.

YOU MUST COMPLETELY READ THE INSTRUCTIONS WITHIN THIS MANUAL, PRIOR TO OPERATING THE HITCH TO PREVENT UNNECESSARY DAMAGE TO THE HITCH, VEHICLE, OR TRAILER.

For more information, please call PullRite at (800) 443-2307.

TABLE OF CONTENTS

SYSTEM WEIGHT RATING VS. COMPONENT WEIGHT RATING.....	3
CAB CLEARANCE.....	3
BASE MODEL NUMBERS.....	4
SUPER 5TH COUPLER KIT.....	5
LUBRICATION / ANNUAL MAINTENANCE.....	6
FIFTH WHEEL PLATE OPERATION.....	7,8
ATTACHING ROCKER ARM TO COLUMN.....	9
HEIGHT ADJUSTMENT.....	10
ROCKER ARM COLUMN PLACEMENT.....	11,12
MOUNTING POST DIFFERENCES BETWEEN BASE MODELS.....	13
HITCH INSTALLATION.....	14,15
MOUNTING POST ADJUSTMENTS.....	15
HITCHING.....	16
SAFETY CHECKS PRIOR TO TOWING.....	16
UNHITCHING / CHALLENGE VS SOLUTION	17
TORQUE TABLE.....	18
RELATED ACCESSORIES.....	19
#4700 EXPLODED VIEW / PARTS LIST.....	20,21
#4800 EXPLODED VIEW / PARTS LIST.....	22,23
#4900 EXPLODED VIEW / PARTS LIST.....	24,25
YEAR LIMITED WARRANTY.....	i
PRODUCT REGISTRATION.....	ii

SYSTEM WEIGHT RATING VS. COMPONENT WEIGHT RATING

A towing system includes each vehicle and component involved in towing. Each item in your towing system has a capacity or weight rating. Your trailer has a Gross Vehicle Weight Rating or GVWR. Your truck has a towing capacity, a payload capacity, and possibly more. In addition, your fifth wheel hitch has a weight rating. This weight rating must be at, or above, the GVWR of your trailer for you to tow safely. In addition, if your truck can tow larger loads (has a larger capacity) than the rating of your hitch, your system is only safe to tow loads at the lower rating, that of the hitch.

Your OE puck mounting system will also have a weight rating, just like your fifth wheel hitch. Many times, these ratings are designed to match, but this is not always the case. Your OE puck mounting system may be higher rated than your fifth wheel hitch, but it also could be lower depending on the components involved. The lowest rating of any one component in the system becomes the rating of the entire system. If your system is rated to 18,000 lbs., and your hitch is rated at 24,000 lbs., the weight rating of the entire system will not be above 18,000 lbs. Other components in the system could lower the actual system rating further.

It is the end users responsibility to ensure a safe towing experience. To this end, it is your responsibility to ensure that the truck, trailer, hitching components, and all other items involved are rated or have a capacity sufficient for the loads involved.

CAB CLEARANCE

If you are towing with a short bed truck, you may be aware that adequate cab clearance is needed for sharp angle turns and damage to the truck cab could occur if the clearance is not calculated correctly.

This formula is a guide for checking clearance: (cab to axle) - (half of the trailer width) = cab clearance

Here are a few examples:

BED LENGTH	CAB-TO-AXLE DIST.	CAB-TO-TRAILER CLEARANCE
8 ft.	56"	56" - 48" = 8" of cab clearance
6 ft.	40"	40" - 48" = - 8" negative cab clearance
5-1/2 ft.	28-1/4"	28.25" - 48" = -19.75 negative cab clearance

As you can see, an 8 ft. bed truck provides more clearance than needed, whereas a 6 ft. bed truck does not allow for a full 90 degree turn and does not provide sufficient cab clearance by 8 inches. Not ideal, but manageable provided you watch your tighter turns. The 5-1/2 ft. bed truck provides even less cab clearance.

If towing with a truck bed that is 6 ft. or less, you must take into consideration that most hitch installations are located center over the truck axle. This hitch will provide a maximum of 4 inches of rearward offset to the truck axle, depending on the front to back adjustment, increasing the cab to trailer turn radius.

For short bed truck applications the Pullrite SuperGlide hitch models will always provide better cab clearance, however, OEX Super 5th and SuperLite hitches do provide the option of additional cab clearance greater than any other fixed or stationary hitch. The trade off is that the OEX, particularly the OEX SuperLite, is much lighter, has a smaller footprint in the bed, is easier to hitch up and is less expensive than a SuperGlide hitch.

HITCH BASE MODELS

The Super 5th OEX is available for Ford, Ram, and GM trucks with OE hitch mounting system (years listed below).

NOTE: This manual uses the #4800 as an example for instruction, however all bases listed below are similar in function.



#4700 for FORD 2010-Present

Hitch Base **#4730**
Super 5th coupler kit **#4820**

25K Tow rating

101 lbs. w/ head plate removed



#4800 for RAM 2013-Present

Hitch Base **#4830**
Super 5th coupler kit **#4820**

25K Tow rating

116 lbs. w/ head plate removed



#4900 for GM 2020-Present

Hitch Base **#4930**
Super 5th coupler kit **#4820**

25K Tow rating

94 lbs. w/ head plate removed

SUPER 5TH COUPLER KIT #4820

All base model hitches with the Super 5th OEX coupling method use the same hardware kit as shown below.

Super 5th OEX coupler kit #4820

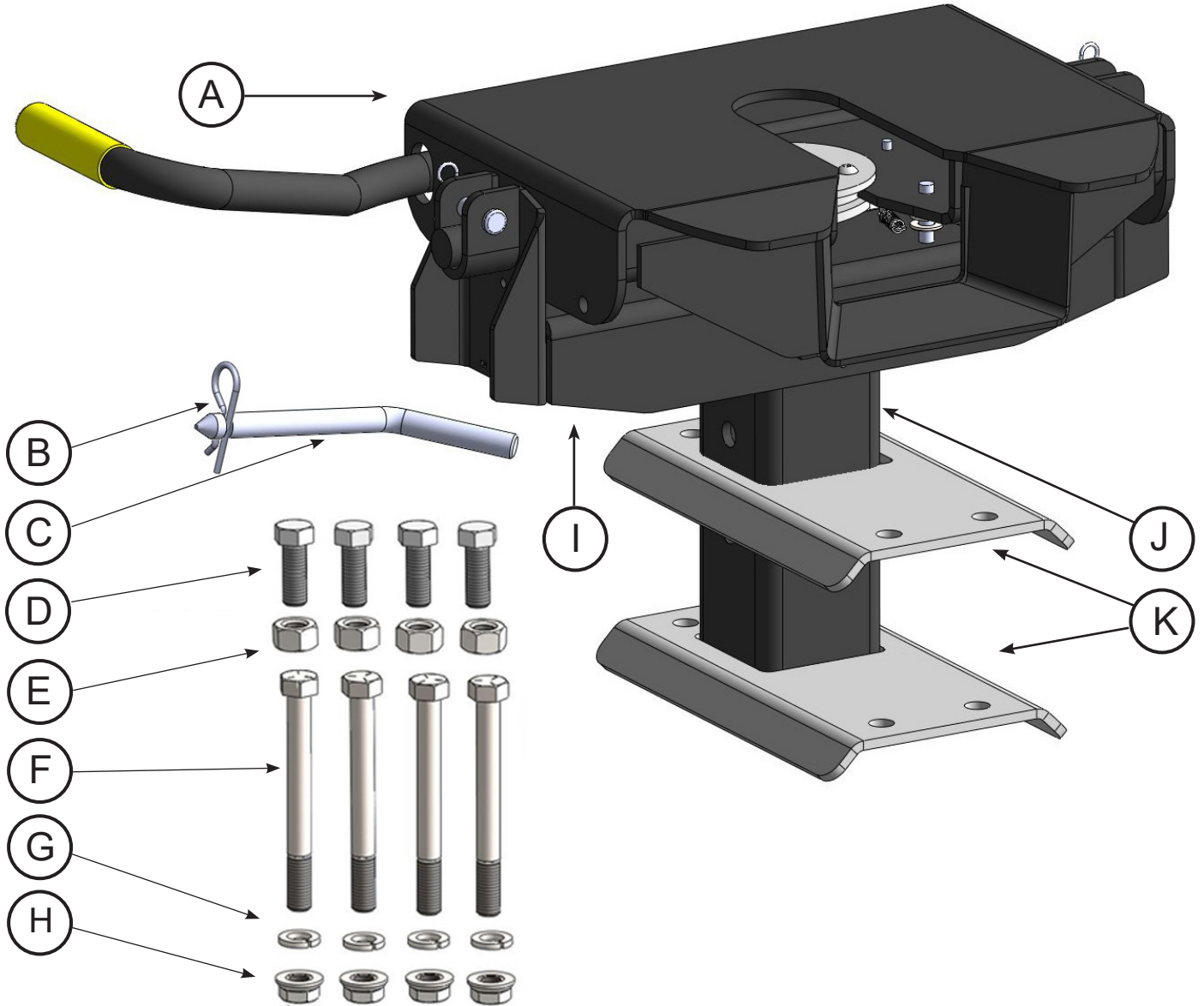

A	HEAD PLATE ASSEMBLY	3601	1
B	# 9 PIN CLIP	98410143	1
C	5/8" DIA. X 4" HITCH PIN	010019	1
D	5/8"-11 X 1.5" TAP BOLT	98010231	4
E	5/8" - 11 HEAVY HEX NUT	98150176	4
F	5/8"-11 X 6" HEX CAP SCREW	98010304	4
G	5/8" LOCK WASHER	98200133	4
H	5/8"-11 SERRATED FLANGE NUT	98150200	4
I	ROCKER ARM ASSEMBLY	4821	1
J	ROCKER ARM COLUMN	4822	1
K	SUPER 5TH OEX COLUMN PLATES	48240001	2

LUBRICATION

DO NOT OPERATE HITCH UNTIL YOU READ THIS SECTION!

HEAD PLATE ASSEMBLY

The Head Plate must be lubricated before each trip or as needed. PullRite recommends using a light lubricant spray such as WD-40 or 3-IN-ONE Oil to prevent the attraction of dust and debris.

Be sure the inside of the Head Plate is free of any obstructions prior to lubrication and before each use, check the Latch System's locking mechanism to ensure it is in working order.

When lubricating the Latch System using a dry graphite spray, place the Latch System in both closed and open positions to cover the spring and pin effectively. If using a wet lube, pull the Release Handle repeatedly between the open and closed positions, so the lubricant is evenly spread among the moving parts. Be sure the King Pin is clean and free from rust. A light coating of wet lubricant should be used before each trip or as needed.

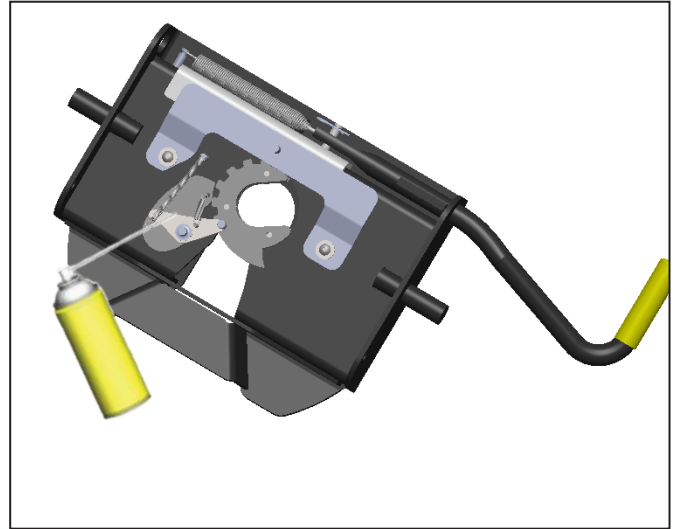

ANNUAL MAINTENANCE

Inspect all hitch hardware to verify that it is securely fastened. Inspect set screws and bolts for tightness and general condition. When storing your OEX Super 5th hitch, you should be sure that the latch mechanism and hitch parts are lubricated with WD-40, or dry graphite spray. Cover the entire assembly to prevent accumulation of dirt, grime, and rust.

FIFTH WHEEL PLATE OPERATION

A better understanding of the plate locking and unlocking operation can be obtained by viewing the working parts from the underside of the plate. The Fifth Wheel Plate can be removed and turned over to view the workings of the mechanism. When operating the Fifth Wheel Plate manually, please be aware that the Lock Jaw Assembly has more movement capability when there is not a king pin present to center the assembly.

1. To open the locking mechanism, lift and pull the Release Handle out until the Lock Catch engages the Lock Jaw Assembly as seen in Fig. 1 & 2 (pages 7,8).
2. As the trailer king pin moves into the plate, it will contact the Lock Lever, in turn forcing the Lock Catch to disengage the Lock Jaw Assembly. This allows the Lock Bar Spring to close the Lock Jaw Assembly behind the King Pin. The King Pin must be fully engaged in the plate slot or the Lock Jaw Assembly will not seat properly, and the Handle Catch will not then engage the inner side wall of the plate. To be certain that the Lock Jaw Assembly has closed fully, attempt to pull the Release Handle without first lifting it.

NOTE: Please note that when lifting the handle to clear the side wall of the plate with the handle catch, it will be necessary to pull with some force to begin the Lock Jaw rotation. Merely lifting the Release Handle will not cause the Handle to “pop” open and rotate the Lock Jaw to the open position.

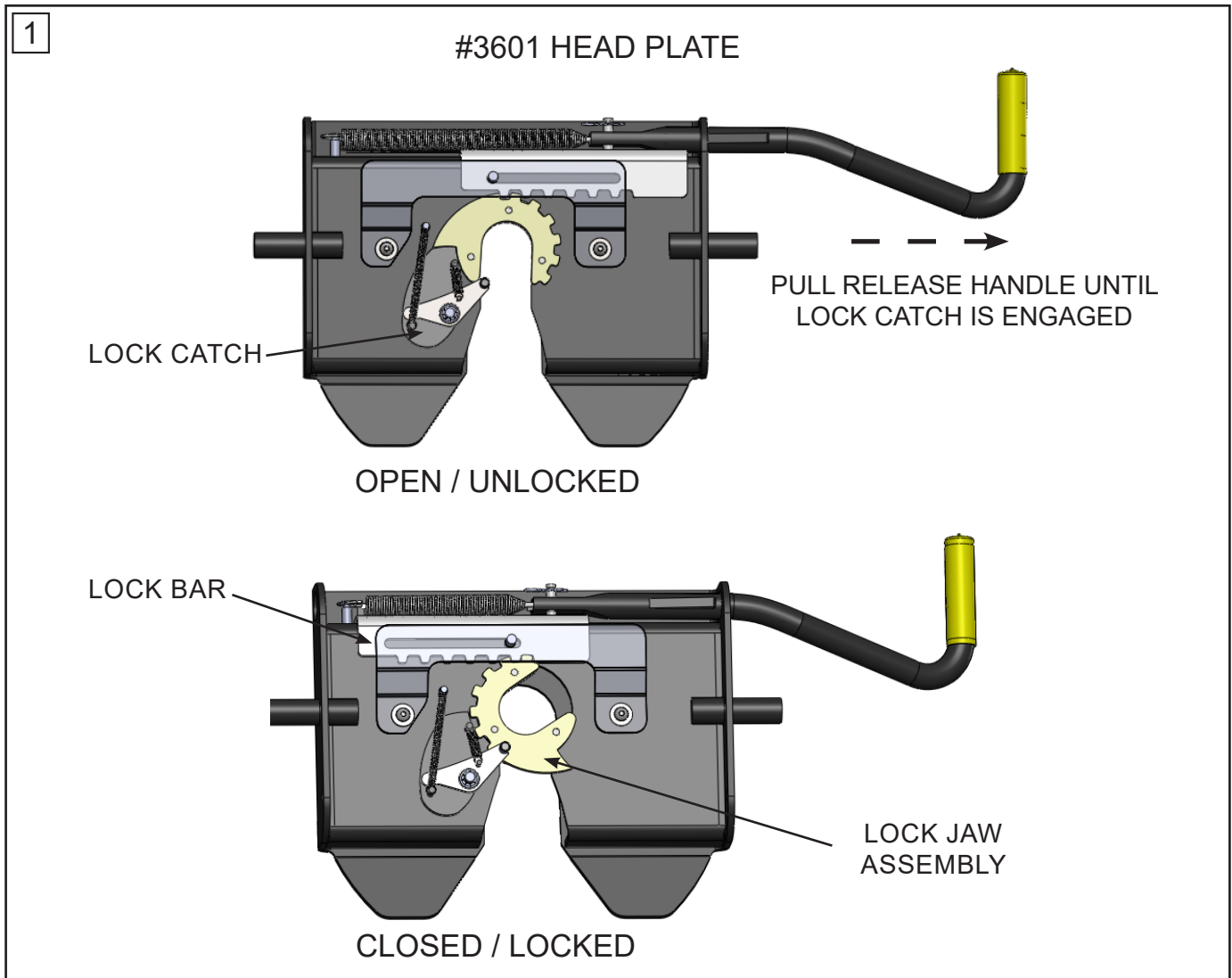

FIFTH WHEEL PLATE OPERATION

CAUTION: DO NOT ATTEMPT TO TRIP THE LOCK MECHANISM WITH YOUR HAND.
USE A PROBE DEVICE TO SIMULATE THE KING PIN ACTION.

2

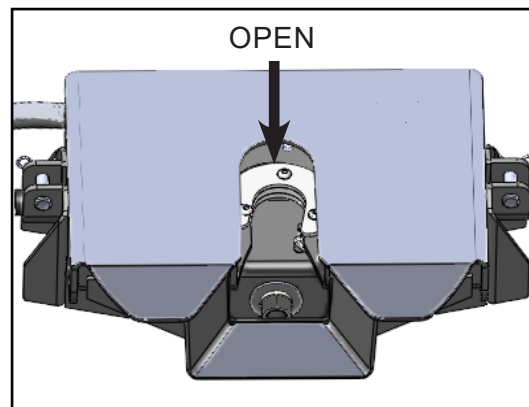
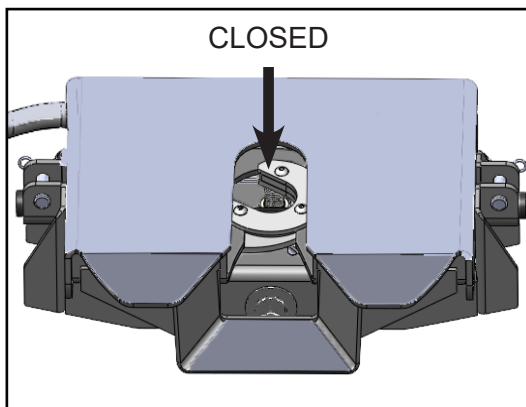
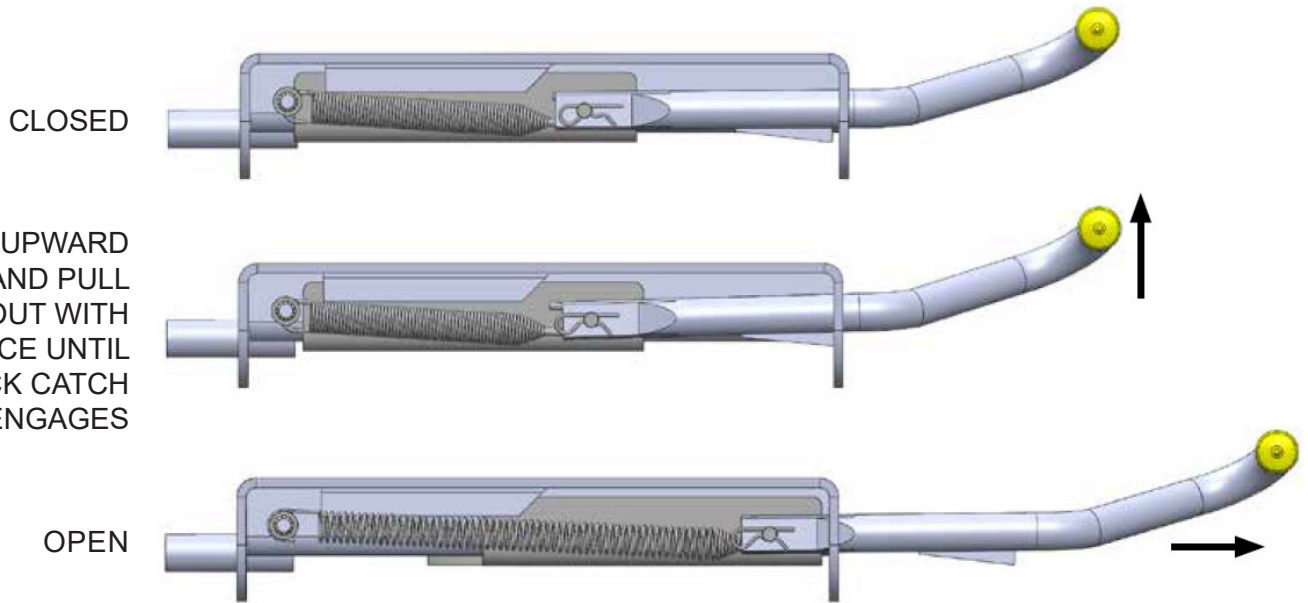

ATTACHING ROCKER ARM TO COLUMN

Attach the Rocker Arm to the Column by following the steps below.

1. Apply a light coat of general purpose grease to the Pivot Bolt shaft and set it aside.

Tip: This step may be easier to assemble with the Rocker Arm upside down as seen below (Fig. 3).

2. Attach the Rocker Arm to the Column by holding the (2) nylon washers flush against the Pivot Bolt holes on both sides of the column (add a little general purpose grease to the nylon washers to adhere them in place on the Column). Sit the Rocker Arm down over top of the Column so that the holes noted below line up (Fig. 3). Nylon washers should not be visible and should still be lined up with the Pivot Bolt holes.

3. Make sure the Pivot Bolt Stop is facing in the direction in which the bolt will be entering the hole (Fig. 4). Press firmly on top of Rocker Arm and push the 7/8" x 6" Pivot Bolt through holes until it emerges out of the opposite side. The bolt head should be flush next to the Pivot Bolt Stop.

4. Slip on the 7/8" flat washer first, then the 7/8" lock washer, and screw on the 7/8" hex nut (hand tighten).

5. Pin the Rocker Arm Column into the hitch base and tighten nut to the point that the Rocker Arm gives resistance when rocking back and forth (Fig. 5). Do not over tighten.

6. Attach the head plate by lining up the Pivot Pins on the Head Plate to the Pivot Locks on Rocker Arm and connect with the clevis pins and clips (Fig. 6).

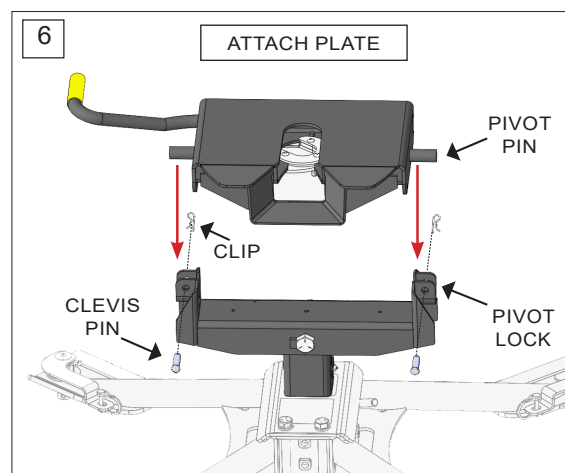
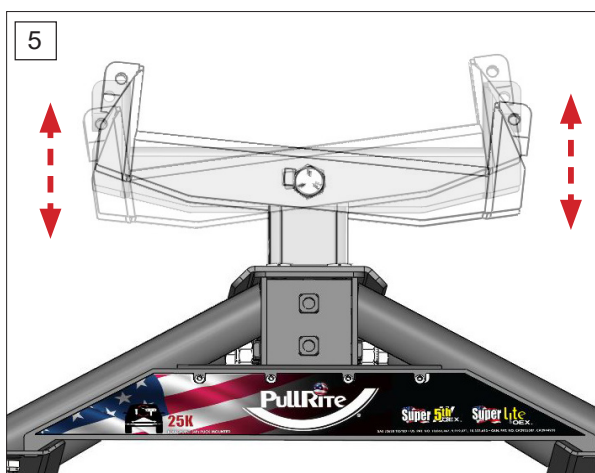
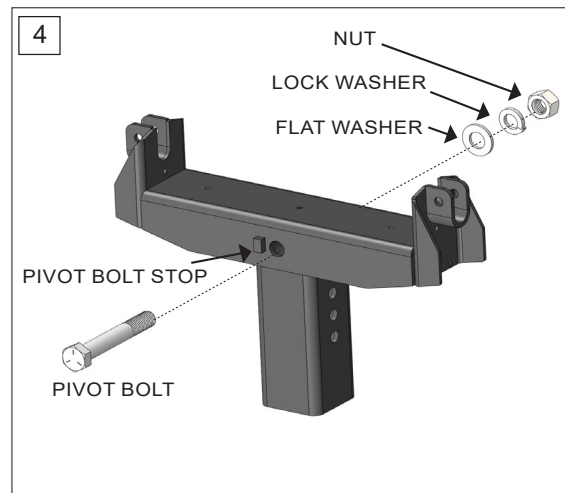
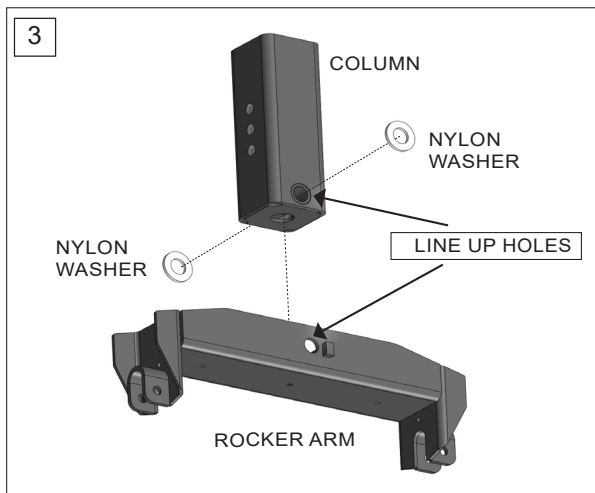

HEIGHT ADJUSTMENT

The Super 5th OEX is height adjustable and can be set in three positions. Refer to the illustration below, and follow each step to adjust your hitch height.

1. Insert column into the hitch base to the desired height by lining up the holes on hitch base and column (Fig.7). Insert hitch pin through hole and clip in place.
2. Take the (4) 5/8 X 1 1/2" Rocker Arm Column set screws with jam nuts fastened on about half way up the threads. Fasten one each into the hitch base directly below the column on the passenger side and driver side, then fasten the other two set screws in either the cab side or tailgate side of hitch base side, whichever is closest to the column.
4. Torque the (4) set screws with a 15/16" socket to 45 foot pounds, then tighten the jam nuts against hitch base with a 15/16" open end wrench.

CAUTION: *Over-tightening these set screws could cause damage to the base. Always torque properly.*

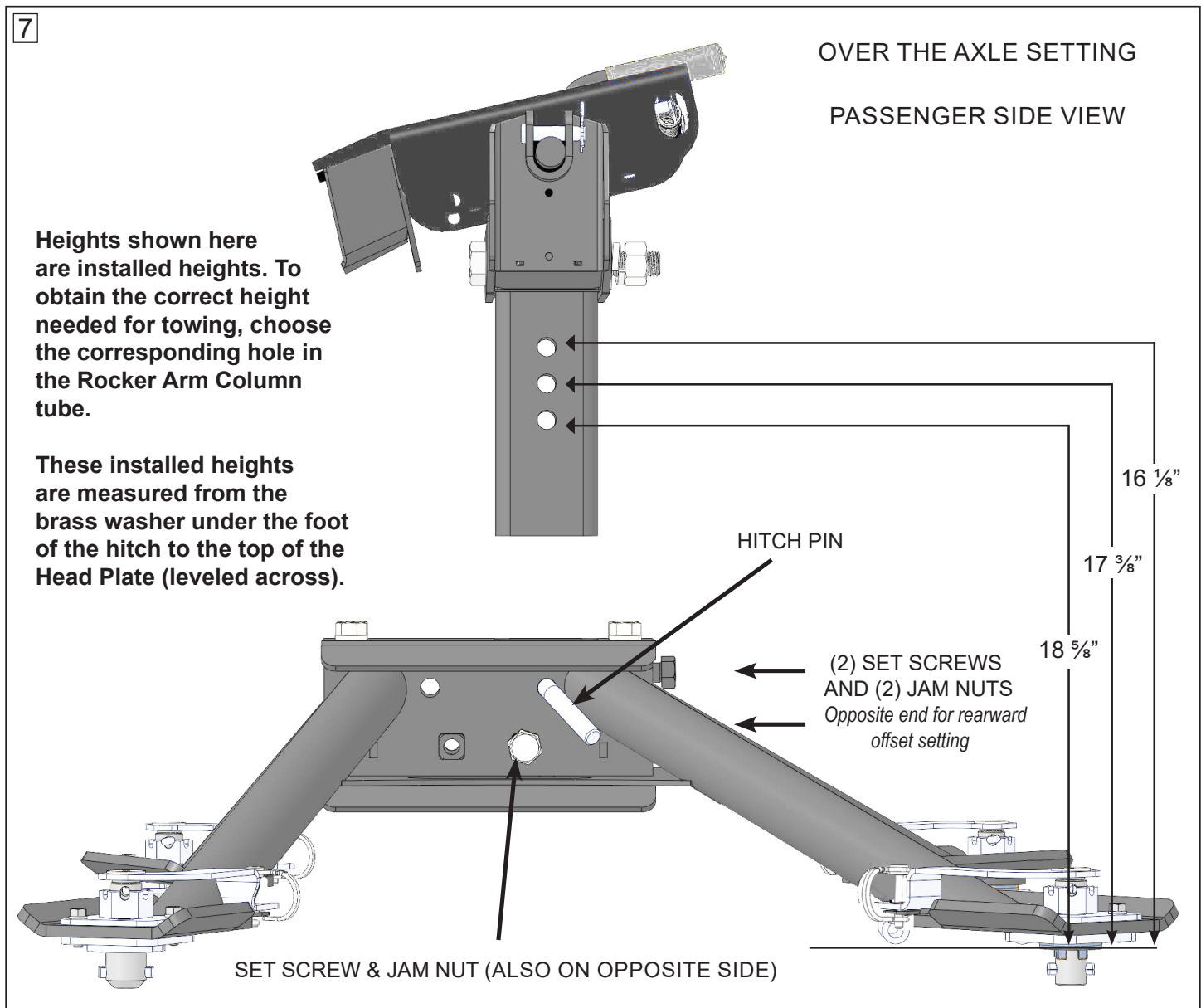

ROCKER ARM COLUMN PLACEMENT

All Super 5th OEX hitches are adjustable. The over the axle position is in Figure 8, but if you would like to add 4" of cab clearance, you can move the Column to the rear position in the base (Fig. 9). Choose the desired setting and follow the steps listed below.

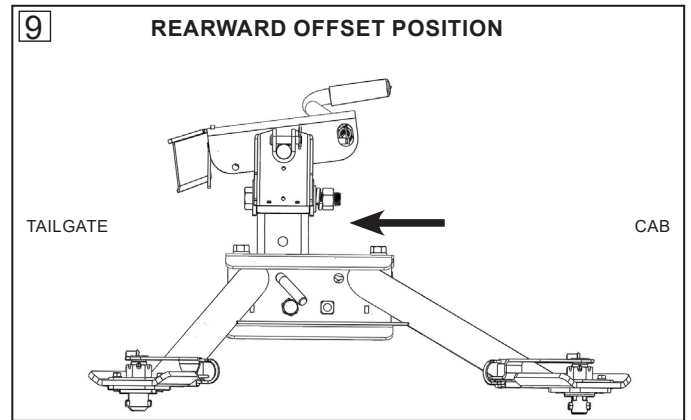
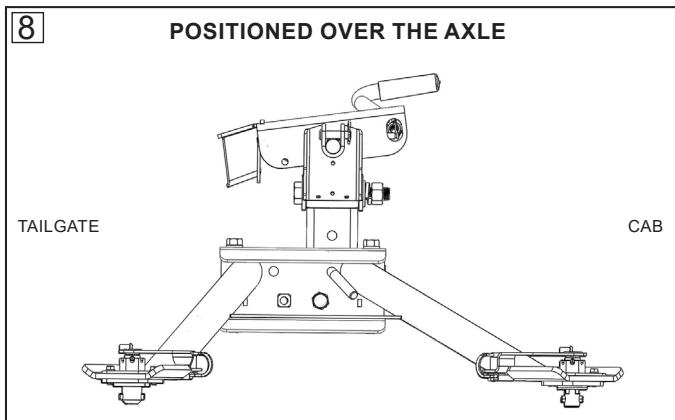

1. After choosing the desired setting from above. Align the holes of the Top Column Plate with the Bottom Column Plate as illustrated in Fig.10 or Fig.11.
2. Insert the (4) 5/8" X 6" Column Location Plate Bolts through the (4) 5/8" Lock Washers and both Column Location Plates. Hand tighten with the (4) 5/8" flange nuts.

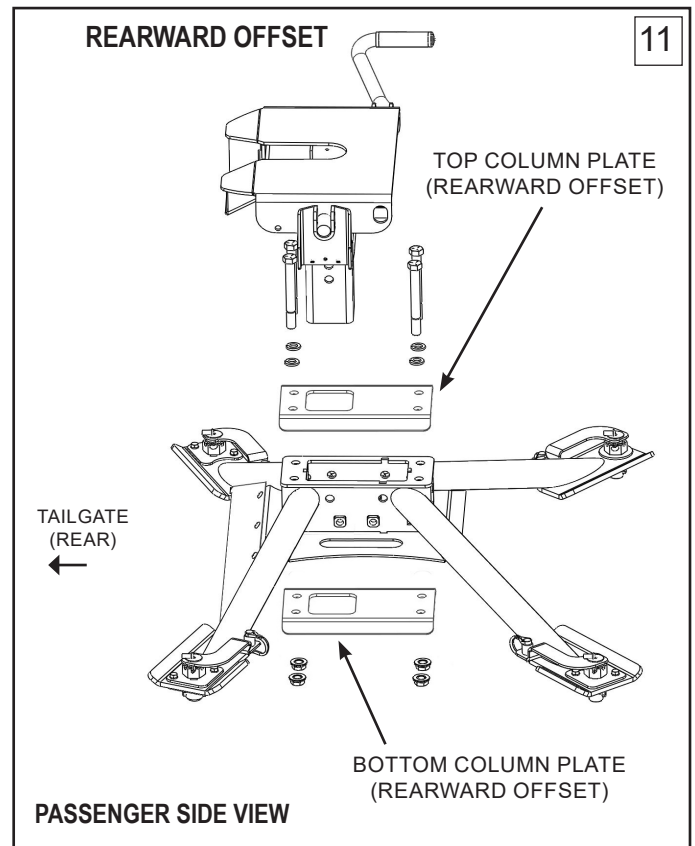
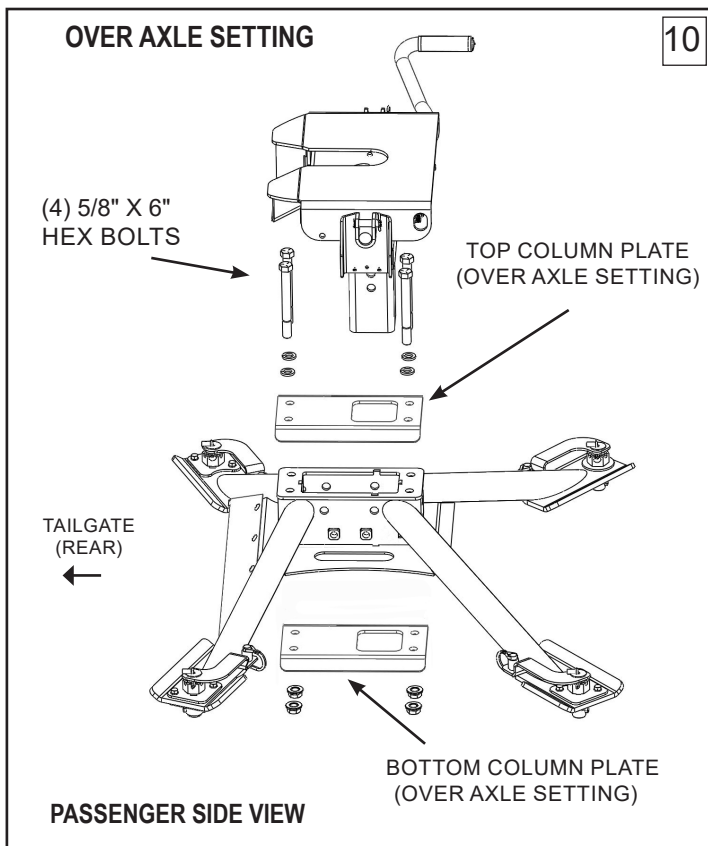

continues next page

ROCKER ARM COLUMN PLACEMENT

8. Insert the Rocker Arm Column through both the top and bottom column plates (Fig.12)
9. Insert Hitch Pin (Fig.13,15) through the height adjustment hole into desired height position and attach clip (see pg.10 for details).
10. Tighten the (4) 5/8" X 6" Column Location Plate Bolts and (4) 5/8 flange nuts with a 15/16" socket to 110 foot pounds.
11. Fasten the (2) 5/8" x 2 1/2" side set screws to the 5/8" jam nuts about half way onto the threads (*do this for the (2) 5/8" X 2" set screws as well for step 12*). Insert into threaded holes on the hitch base on both passenger side and driver side directly below the column (over the axle - Fig.13, rearward offset - Fig.15).
12. - For **over the axle** setting, insert the (2) 5/8"-11X 2" front set screws and jam nuts in the front (cab side) panel (Fig.14).
 - For **rearward offset** setting, insert the (2) 5/8"-11X 2" front set screws and jam nuts to the back (tailgate side) panel (Fig.16).
13. Tighten the set screws with a 15/16" socket to 20 foot pounds and snug tighten the jam nuts with an open end wrench.

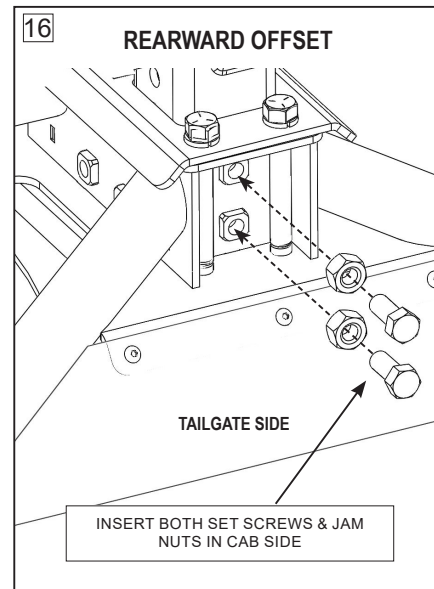
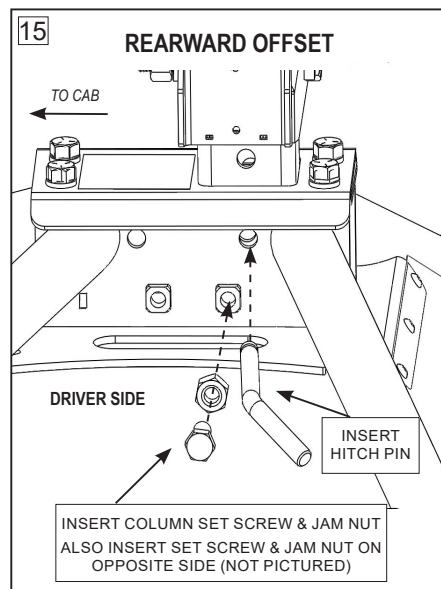
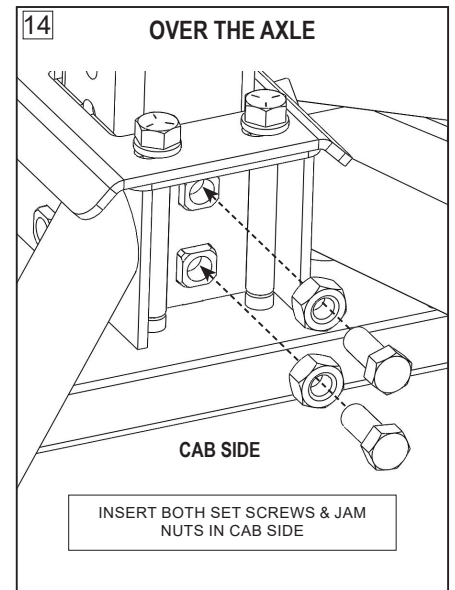
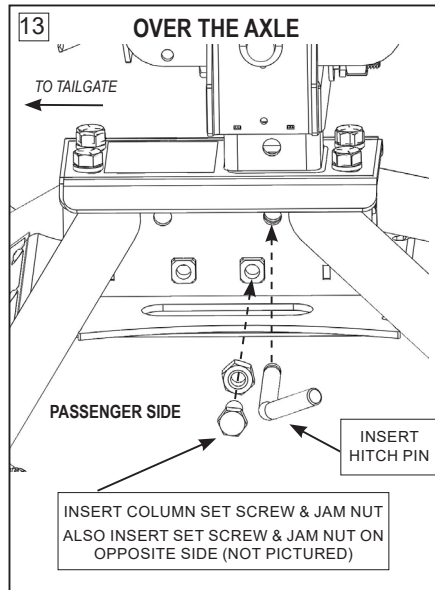
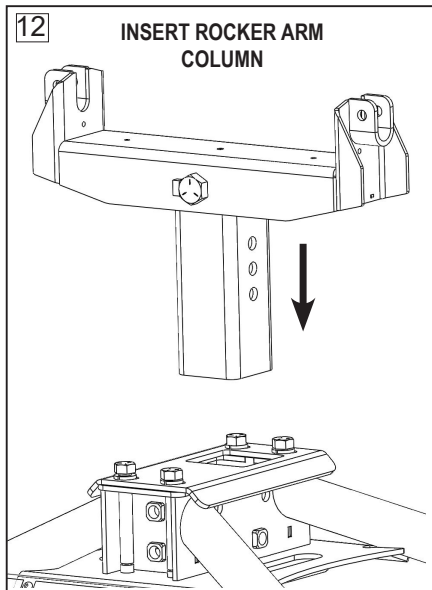

MOUNTING POST DIFFERENCES BETWEEN HITCH BASE MODELS

#4715 for FORD 2010-Present

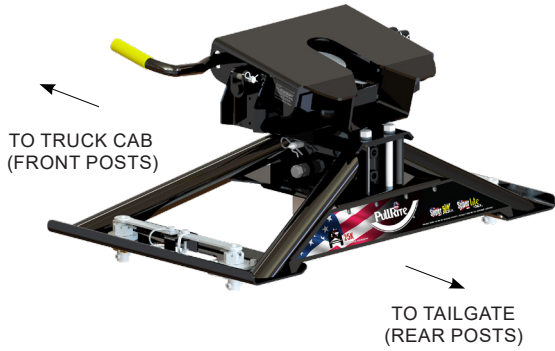

FRONT POSTS

DRIVER SIDE

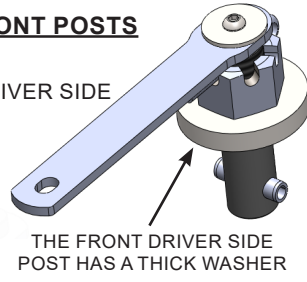

THE FRONT DRIVER SIDE POST HAS A THICK WASHER

PASSENGER SIDE

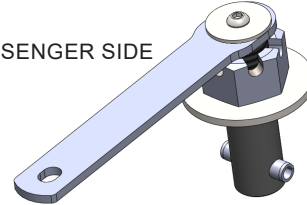

REAR POSTS

DRIVER SIDE SAME AS PASSENGER SIDE

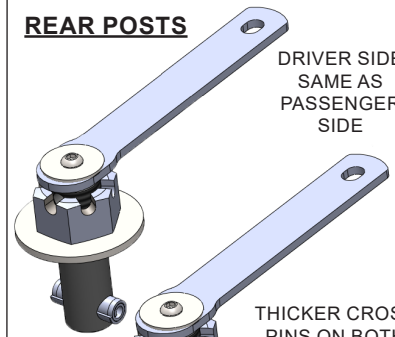

THICKER CROSS PINS ON BOTH REAR POSTS

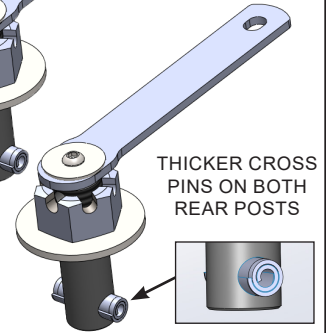

#4815 for RAM 2013-Present

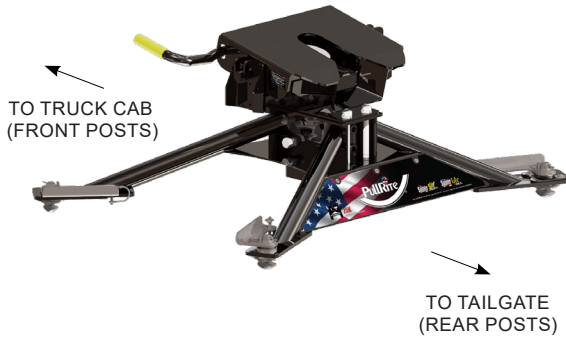

FRONT POSTS

DRIVER SIDE

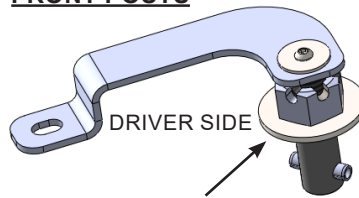

THE FRONT DRIVER SIDE POST HAS A 1" WASHER

PASSENGER SIDE

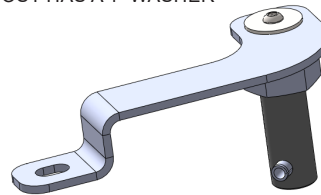

REAR POSTS

DRIVER SIDE

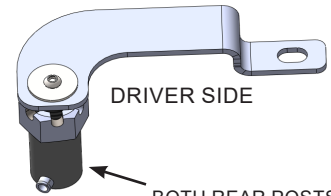

BOTH REAR POSTS ARE LARGER IN DIAMETER

PASSENGER SIDE

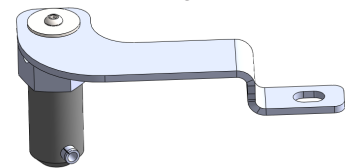

#4915 for GM 2020-Present

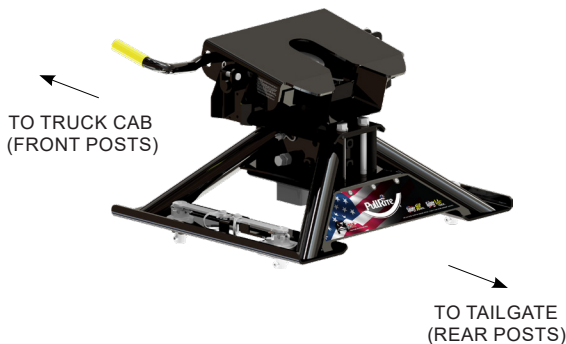

FRONT POSTS

DRIVER SIDE

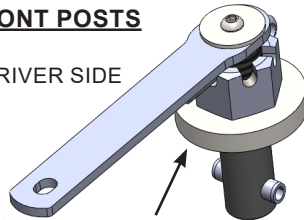

THE FRONT DRIVER SIDE POST HAS A THICK WASHER

PASSENGER SIDE

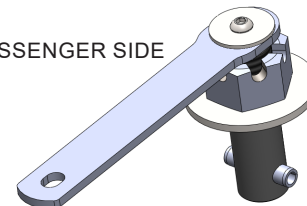

REAR POSTS

DRIVER SIDE SAME AS PASSENGER SIDE

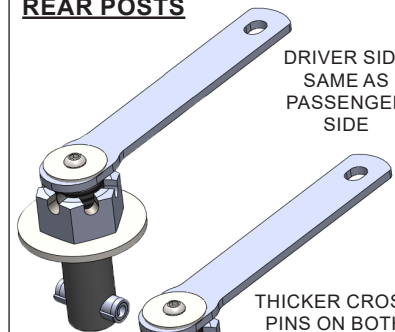

THICKER CROSS PINS ON BOTH REAR POSTS

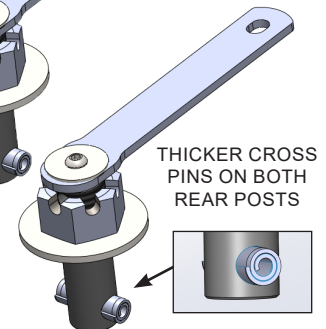

HITCH INSTALLATION

1. Insert the (2) brass washers into the truck bed pucks closest to the cab until they are pressed in snug (Fig.17). Place OEX Super 5th post holes directly over the pucks and drop hitch in place until seated firmly in the Brass Washers. The hitch head opening should be facing the tailgate (Fig.20).

NOTE: Before inserting Mounting Posts for the first time, you will need to adjust them to obtain a custom fit as explained in the MOUNTING POST ADJUSTMENTS section on page 15.

2. To insure the best results for the Mounting Posts to drop into the puck, slightly loosen the 5/16" hex bolts on the mounting post plates with a 1/2" socket so that the plates move freely on the OEX foot as seen below (Fig.18).
3. The OEX foot on the driver side front does not have an Mounting Post Plate; this is where to start inserting the Mounting Posts (Fig.20). Work clockwise over to the front passenger side post and on around the hitch.

NOTE: The front posts (cab side) have smaller cross pins than the rear posts (tailgate side).

4. Insert each Mounting Post assembly handle into the hitch by aligning the post's Cross Pins in line with the post hole slot cut in the OE Mounting Post Plates, as seen below (Fig.19).

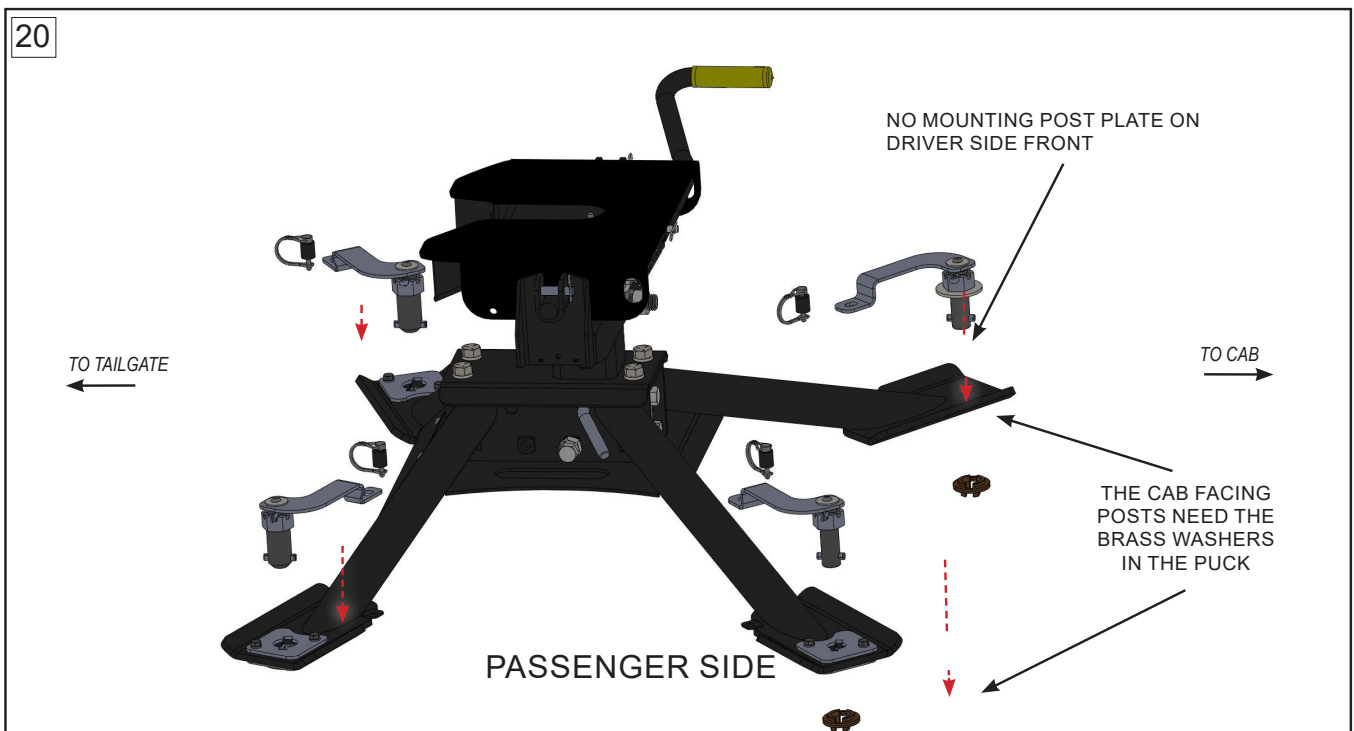
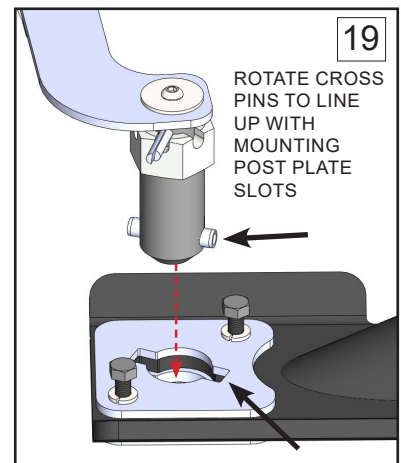
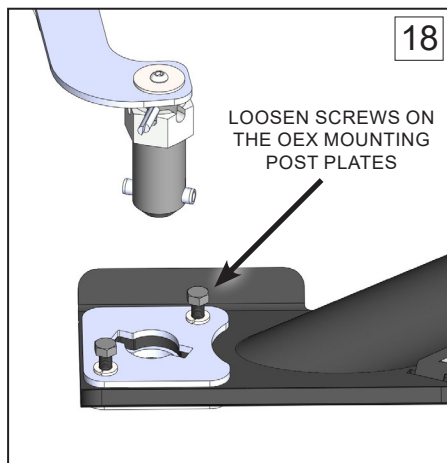
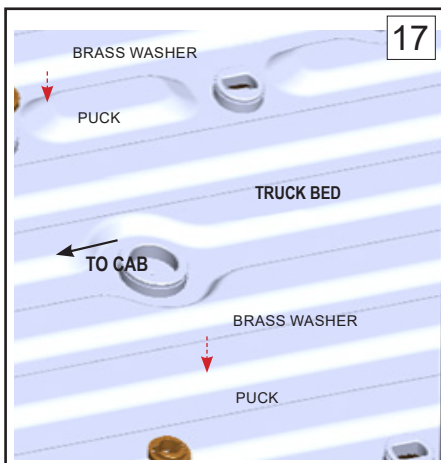

HITCH INSTALLATION

5. Press down while inserting Mounting Posts and rotate 90° (Fig.21), until hole in handle lines up with the hole on tab on hitch base (Fig.22).The Mounting Posts should feel firmly locked in place.
6. Tighten the Mounting Post Plate Hex Bolts on the OEX feet to 13 foot pounds.
7. Slide bail pins in through each lock tab and handle (Fig.22). A padlock can also be used here to help prevent theft.

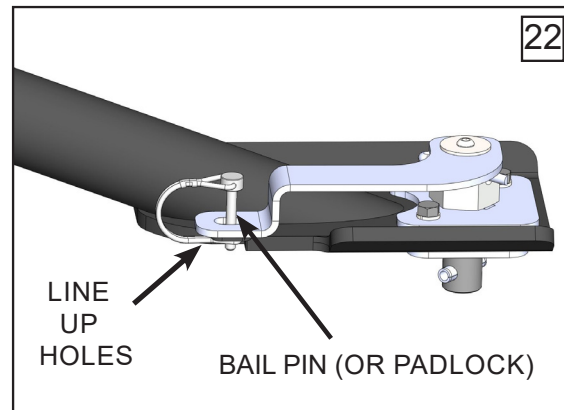
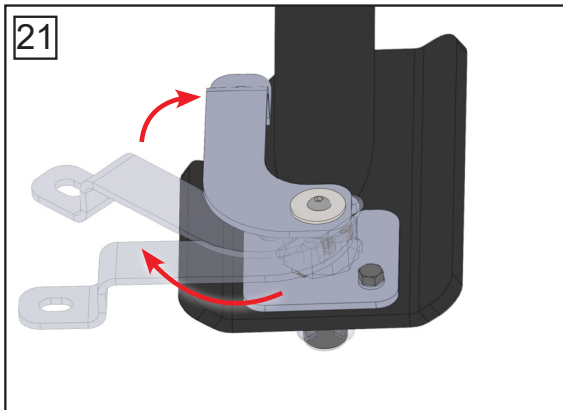

MOUNTING POST ADJUSTMENTS

The OEX Super 5th Mounting Post needs a custom adjustment to fit your pucks. To adjust the Mounting Post, perform the

1. Remove the cotter pin from the Mounting Post Assembly (Fig.23).
2. Rotate the castle nut open until it is near the handle and then insert the assembly through the opening in the hitch base into the puck and rotate the handle to the closed position. Next, lift up on the handle so that the top of the cross pin touches the bottom of the puck. Thread the nut down until it bottoms out against the hitch base.

-If the handle rotates with too much difficulty, then back off the castle nut one crenal and try it again.

-Likewise, if the handle rotation is too easy, rotate the castle nut one additional crenal. Keep repeating this action until you have a snug fit.
3. Once you have a snug fit, remove the post assembly and insert the cotter pin. Bend the end of the cotter pin to secure the nut in the chosen position (Fig.24).
4. Re-latch the Mounting Handles as shown on the HITCH INSTALLATION section above.

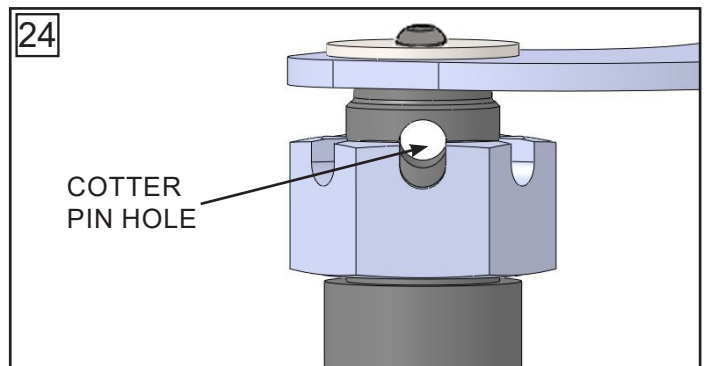
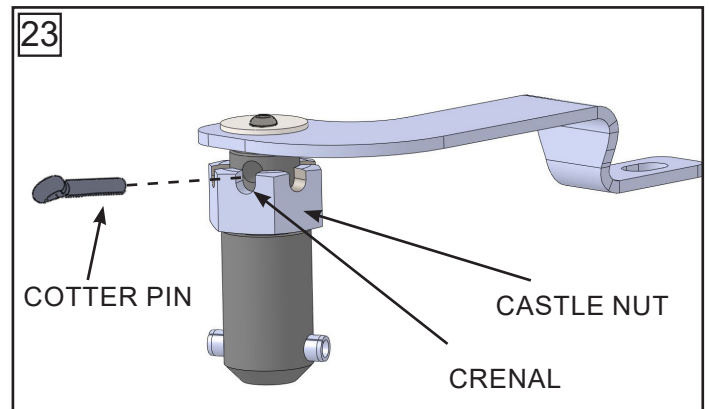

HITCHING

WARNING: Never perform any of the following actions while any part of a person is between the vehicle and trailer.

1. Align your truck with the center of the trailer. The truck should be close to parallel to the centerline of the trailer.
2. Block the trailer wheels so the trailer will not roll back.
3. Lower your tailgate and back up until there is about 6" of clearance between the Super 5th and the end of the fifth wheel plate. Raise or lower the front of the trailer so the bottom of the plate is aligned slightly above the beginning of the ramp area of the Fifth Wheel Plate (Fig. 24). This procedure will cause the front edge of the trailer plate to "ride up" the ramp and flatten or tilt the hitch plate into a parallel position.

CAUTION: If this procedure is not followed, the king pin may bind in the plate mechanism and not lock in properly. Following the procedure as outlined in Step 3 will ensure that you will not "high hook" the king pin on the plate. "High hooking" occurs when backing your hitch into a trailer that is set too high, resulting in the lower flange of the king pin to wedge itself against the metal edge of the lower horseshoe piece or against the Lock Jaw Assembly. Damage to the Lock Jaw Assembly may result and not allow smooth operation of the closing mechanism.

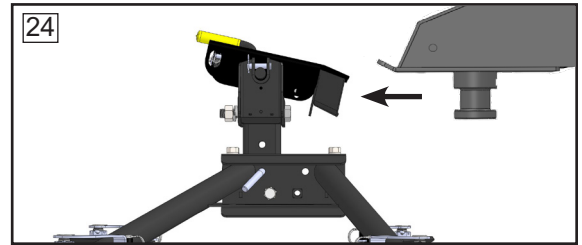

4. The Fifth Wheel Latch must be in the open position (Fig. 25). Also see pages 7,8. Lift and pull out the Release Handle to open the Lock Jaw Assembly.

CAUTION: Damage will result if you attempt to hook up with the Lock Jaw Assembly in the closed position.

5. Back up the truck in one fluid motion and without hesitation, so the king pin enters the center of the Fifth Wheel Plate, activating the Lock Jaw mechanism.

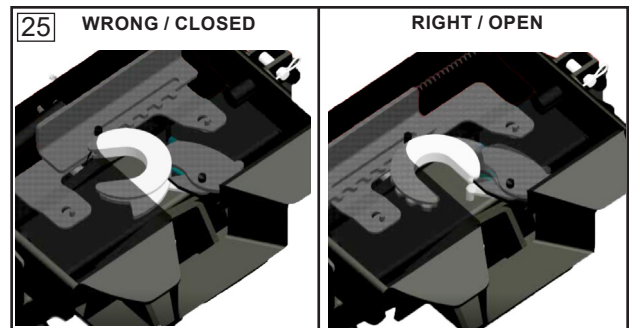

SAFETY CHECKS PRIOR TO TOWING

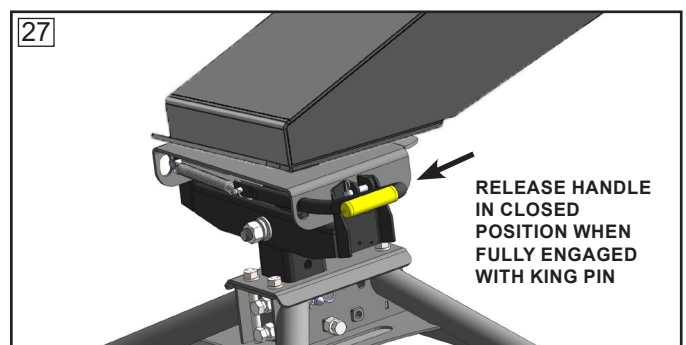
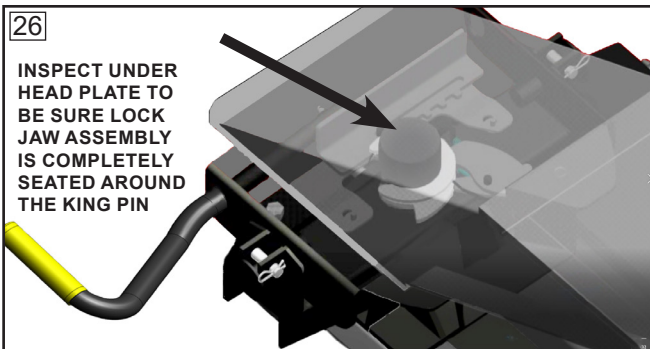

FAILURE TO PERFORM THESE SAFETY CHECKS MAY RESULT IN DAMAGES TO TRUCK AND TRAILER.

1. Prior to towing, it is imperative to know if you are hooked up properly and the king pin is engaged:
 - With a flashlight, visually inspect under the head plate to be sure the Lock Jaw Assembly is completely seated around the king pin (Fig. 26).
 - Give the handle a tug to be sure that the Release Handle has fully returned to the closed position (Fig. 27).
2. Raise the trailer jack base plates just above the ground, lock your trailer brakes, then pull the tow vehicle slowly forward, putting a strain on the trailer.
3. When you are assured that the trailer is safely hooked up, raise your trailer jacks into their fully retracted position.

UNHITCHING

WARNING: *Never perform any of the following actions while any part of a person is between the vehicle and the trailer.*

1. Once you have the trailer located and are ready to unhitch, block the trailer wheels so it will not roll back or forward. Back into the blocked trailer slightly and set the parking brake while you are still in gear. This action will relieve pressure on the lock mechanism before attempting to release the latch mechanism.
2. Lower the trailer jacks to the point of just touching the ground, but do not raise the trailer at this point.
3. Open the Lock Jaw Assembly by first lifting, then pulling the Release Handle towards you.
4. Lower the trailer jacks until the bottom of the king pin box is almost free of the top of the Fifth Wheel Plate. Make certain that the bottom of the king pin is not so high that binding on the hitch Lock Catch would result.
5. After lowering the truck's tailgate, disconnect the trailer electrical cord and break-away switch cable, then pull forward.
6. As the king pin slides from the Fifth Wheel Plate, notice that the locking mechanism remains open once the king pin is removed.

CAUTION: *If it should be necessary to reposition your trailer, you must follow the hitching procedures to ensure the lock mechanism is latched around the king pin before moving the trailer.*

CAUTION: *You may wish to keep the head plate lock mechanism closed until you are ready to re-hitch to avoid injury or accidents to children or adults who attempt to operate the lock mechanism.*

DO NOT ATTEMPT TO TRIP THE LOCK MECHANISM WITH YOUR HAND. USE A PROBE TO SIMULATE THE KING PIN.

CHALLENGE VS. SOLUTION

CHALLENGE	SOLUTION
Cannot open the Release Handle.	You may have too much rearward pressure against the lock mechanism. Back your truck slightly to relieve pressure and continue the unhitching procedures.
Plate seems dry - Can I use a lubrication disk?	Yes.
Trailer overhang is hitting the truck bed rails when the trailer and truck are at sharp angles.	Raise or lower the hitch plate height and/or lower the king pin box. There should be at least 6" between the top of the bed rails and bottom of the trailer.
I need to have a professional evaluate my Super 5th OEX.	Contact PullRite's Customer Service Dept. at (800) 443-2307. Your needs will be assessed and resolved by PullRite or you will be directed to an authorized PullRite Service Center.



TORQUE TABLE

Apply these torque specifications for the corresponding items listed below upon installation and subsequent inspections of the Super 5th OEX. See parts list for identification of items listed on this table.

HARDWARE	SIZE	TORQUE SPECS
COLUMN LOCATION PLATE BOLTS	5/8"	110 FT. LBS. - FOUR BOLTS THROUGH COLUMN PLATES TIGHTEN WITH NUTS
COLUMN SET SCREWS	5/8"	20 FT. LBS. - FOUR SET SCREWS AND JAM NUTS SECURING COLUMN
OEX MOUNTING POST PLATES BOLTS	5/16"	13 FT. LBS. - SIX BOLTS TO TIGHTEN AFTER HITCH IS SET IN TRUCK BED.
OE MOUNTING POST SCREW	1/4"	4 FT. LBS. - ONE BUTTON HEAD SCREW TIGHTEN AT TOP OE MOUNTING POST

RELATED ACCESSORIES

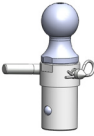
PullRite offers these excellent accessories for towing. These products are American made and available now through PullRite dealers.

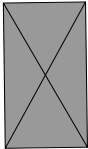
IMAGE	DESCRIPTION	PART #
	<p>30K OE Series Gooseneck Ball</p> <ul style="list-style-type: none"> -Fits truck's factory-equipped Tow Prep Package. -American made with patented TwistLock technology. -Zinc finish 	4436
	<p>30K OE Series Gooseneck Ball w/ Plate</p> <ul style="list-style-type: none"> -Fits truck's factory-equipped Tow Prep Package. -American made with patented TwistLock technology. -Hard Nickel or Zinc finish, resistant to scratches. 	4437
	<p>Pinbox Rubber Isolator 4446</p> <p>When the rubber in your Rotoflex is already working out of place, this isolator will enable you to force it back in place and keep it there.</p>	4446
	<p>Pinbox Rubber Isolator 4447</p> <p>Keeps rubber on Rota-Flex pinboxes from working its way out of place. Easier to install upgrade of the #4446 provided rubber is still in place.</p>	4447
	<p>SlipPlate Dry Graphite Lubricant Spray</p> <p>Case of 12 - 12 ounce cans</p> <p>(Single 12 ounce can - #33040301)</p>	330403

4700 SUPERLITE OEX EXPLODED VIEW

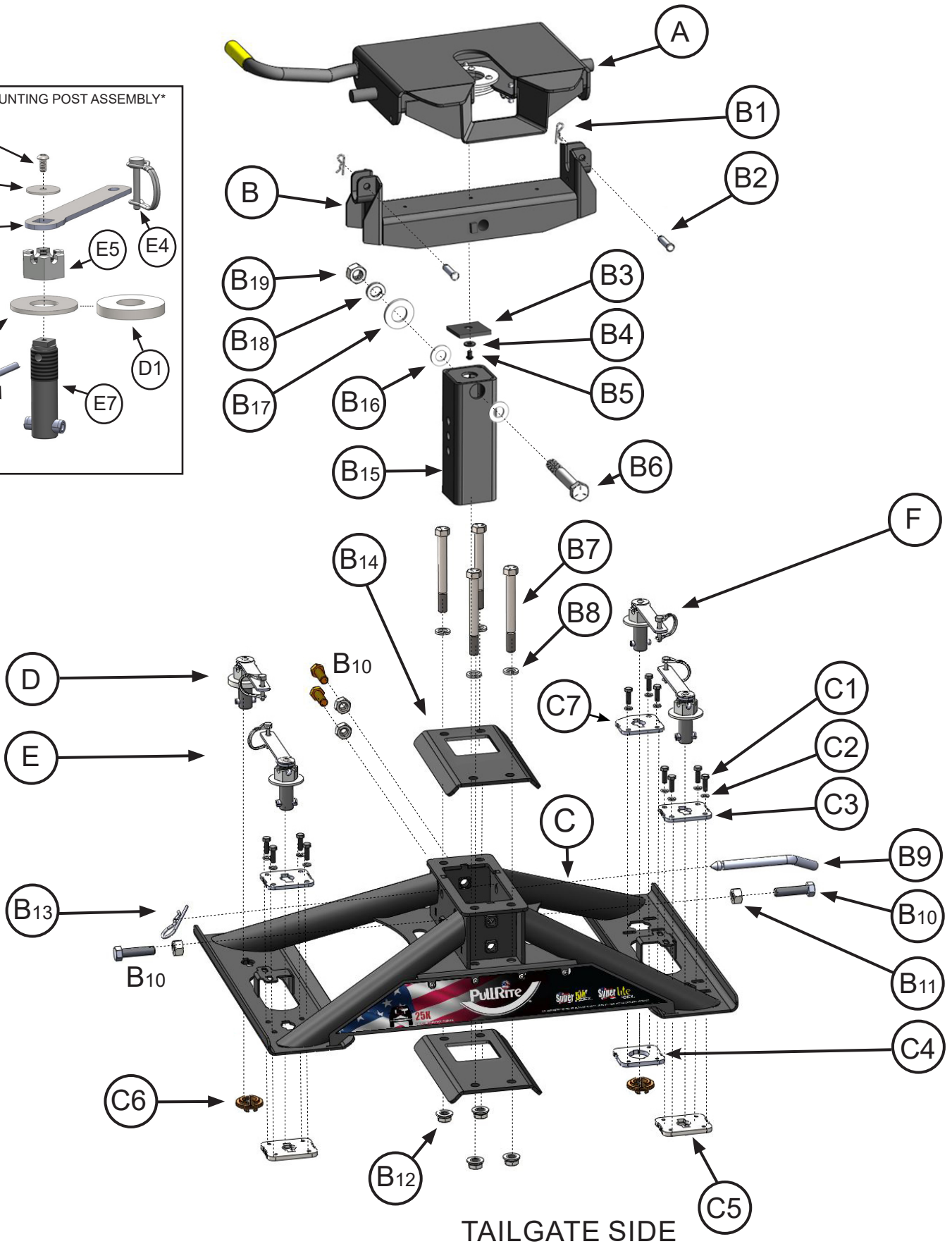
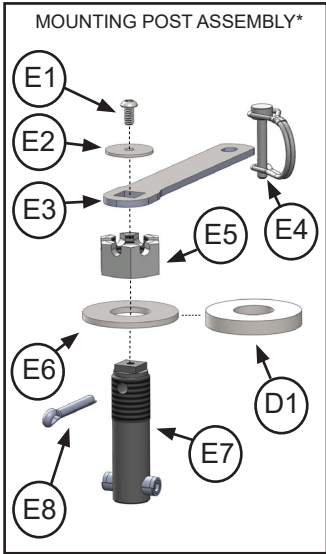

TAILGATE SIDE

#4700 PARTS LIST

	NAME	PART NO.	QTY	DESCRIPTION
A	HITCH PLATE ASSEMBLY	3601	1	
B	ROCKER ARM	4821	1	
C	FORD OEX HITCH BASE	4730	1	
D	OEX DS FRONT MOUNTING POST KIT	47341	1	
E	OEX REAR MOUNTING POST KIT	47343	2	
F	OEX PS FRONT MOUNTING POST KIT	47342	1	
SUPER 5TH COUPLER KIT # 4820 (INCLUDES HITCH PLATE)				
B1	HITCH PIN CLIP	98410127	2	#3 13 GAUGE 1.63" OAL HITCH PIN CLIP
B2	CLEVIS PIN	98410111	2	1/2" X 2" CLEVIS PIN
B3	NEOPRENE SPRING	48210001	1	2' X 2' NEOPRENE RUBBER
B4	5/16" WASHER	98250160	1	5/16" FLAT WASHER
B5	BUTTON HEAD SCREW	98010273	1	5/16"-18 X 3/4" BHSCS
B6	ROCKER ARM BOLT	98010303	1	7/8"-9 X 6" LONG HCS
B7	COLUMN LOCATION PLATE BOLT	98010304	4	5/8"-11 X 6" HCS
B8	COLUMN LOCATION PLATE LOCK WASHER	98200133	4	5/8" LOCK WASHER
B9	HITCH PIN	010019	1	5/8" DIA. X 4" HITCH PIN
B10	COLUMN SET SCREW	98010231	4	5/8"-11 X 1 1/2" TAP BOLT
B11	HEAVY HEX JAM NUT	98150176	4	5/8" - 11 HEAVY HEX NUT
B12	COLUMN LOCATION PLATE FLANGE NUT	98150200	4	5/8"-11 SERRATED FLANGE NUT
B13	PIN CLIP	98410143	1	# 9 PIN CLIP
B14	COLUMN LOCATION PLATE	48142001	2	
B15	ROCKER ARM COLUMN	4822	1	
B16	NYLON WASHER	41030405	2	7/8 NYLON WASHER
B17	ROCKER ARM WASHER	98200175	1	7/8" WASHER
B18	ROCKER ARM LOCK WASHER	98200174	1	7/8" LOCK WASHER
B19	ROCKER ARM BOLT NUT	98150215	1	7/8" - 9 HEX NUT
BASE HARDWARE KIT #260204				
C1	COLUMN LOCATION PLATE BOLT	98010304	4	5/8"-11 X 6" HCS
C1	MOUNTING POST PLATE BOLT	98010244	11	5/16"-18 X 1"
C2	5/16" LOCK WASHER	98200159	11	5/16" LOCK WASHER
C3	DS & PS BACK TOP MOUNTING POST PLATES	47330002	2	
C4	PS FRONT BOTTOM MOUNTING POST PLATE	47330004	1	
C5	DS & PS REAR BOTTOM MOUNTING POST PLATE	47331001	2	
C6	MOUNTING WASHER	13070001	2	
C7	PS FRONT TOP MOUNTING POST PLATE	47330003	1	
*MOUNTING POST ASSEMBLY				
D1	DS FRONT TOP MOUNTING POST WASHER	47330001	1	WASHER FOR DRIVER SIDE FRONT MOUNTING POST
E1	1/4-20 BUTTON HEAD SCREW	98410241	1	1/4-20 X 1/2" LONG BHSCS
E2	1/4 FLAT WASHER	98250150	1	1/4" OVERSIZED FLAT WASHER
E3	MOUNTING POST HANDLE RAM	48354001	1	
E4	BAIL PIN	98410581	1	1/4" DIA. x 1 1/2" BAIL PIN
E5	SLOTTED NUT	98150121	1	1"-14 SLOTTED NUT
E6	DS FRONT BASE FOOT FLAT WASHER	98250100	1	1" USS FLAT WASHER
E7	MOUNTING POST	18050101	1	
E8	COTTER PIN	98410567	1	1/4" X 2" COTTER PIN

4800 SUPERLITE OEX EXPLODED VIEW

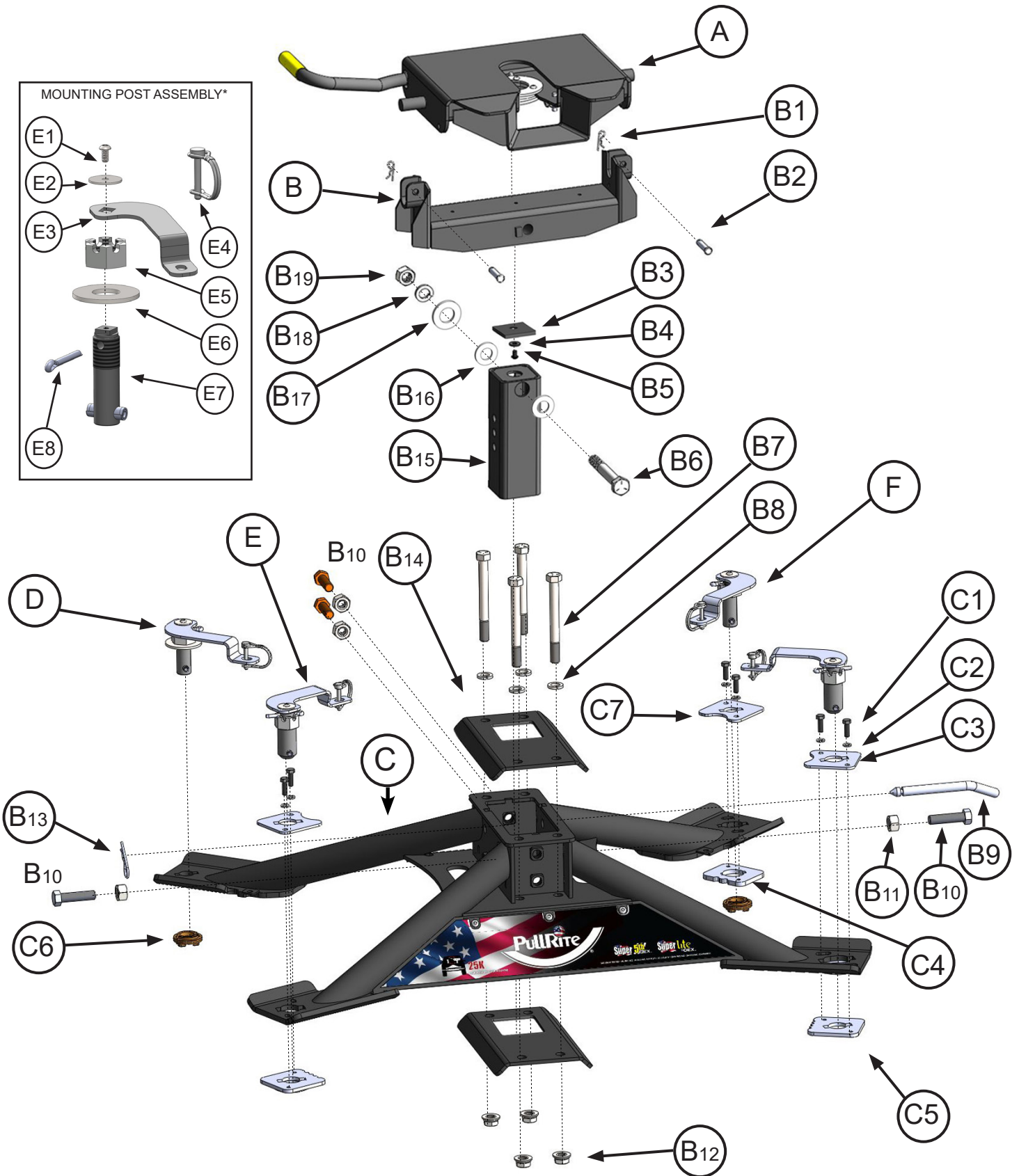
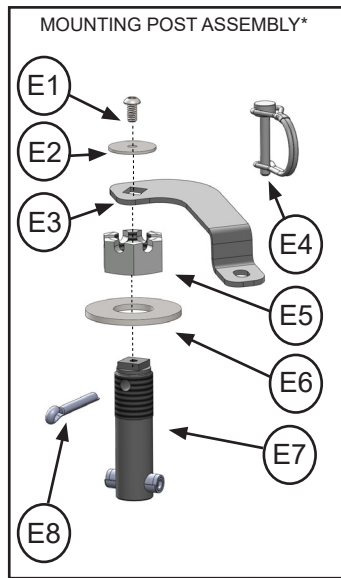

TAILGATE SIDE

#4800 PARTS LIST

	NAME	PART NO.	QTY	DESCRIPTION
A	HITCH PLATE ASSEMBLY	3601	1	
B	ROCKER ARM	4821	1	
C	RAM OEX HITCH BASE	4830	1	
D	OEX DS FRONT MOUNTING POST	48341	1	
E	OEX REAR MOUNTING POSTS	48343	2	
F	OEX PS FRONT MOUNTING POST	48342	1	
SUPER 5TH COUPLER KIT # 4820 (INCLUDES HITCH PLATE)				
B1	HITCH PIN CLIP	98410127	2	#3 13 GAUGE 1.63" OAL HITCH PIN CLIP
B2	CLEVIS PIN	98410111	2	1/2" X 2" CLEVIS PIN
B3	NEOPRENE SPRING	48210001	1	2" X 2" NEOPRENE RUBBER
B4	5/16" WASHER	98250160	1	5/16" FLAT WASHER
B5	BUTTON HEAD SCREW	98010273	1	5/16"-18 X 3/4" BHSCS
B6	ROCKER ARM BOLT	98010303	1	7/8"-9 X 6" HCS
B7	LOCATION PLATE BOLT	98010304	4	5/8"-11 X 6" HCS
B8	LOCATION PLATE LOCK WASHER	98200133	4	5/8" LOCK WASHER
B9	HITCH PIN	010019	1	5/8" DIA. X 4" HITCH PIN
B10	COLUMN SET SCREW	98010231	4	5/8"-11 X 1 1/2" TAP BOLT
B11	HEAVY HEX JAM NUT	98150176	4	5/8" - 11 HEAVY HEX NUT
B12	LOCATION PLATE FLANGE NUT	98150200	4	5/8"-11 SERRATED FLANGE NUT
B13	PIN CLIP	98410143	1	
B14	LOCATION PLATE	48142001	2	
B15	ROCKER ARM COLUMN	4822	1	
B16	NYLON WASHER	41030405	2	7/8" NYLON WASHER
B17	ROCKER ARM WASHER	98200175	1	7/8" WASHER
B18	ROCKER ARM LOCK WASHER	98200174	1	7/8" LOCK WASHER
B19	ROCKER ARM BOLT NUT	98150215	1	7/8" - 9 HEX NUT
BASE HARDWARE KIT #260204				
C1	COLUMN LOCATION PLATE BOLT	98010304	4	5/8"-11 X 6" HCS
C1	MOUNTING POST PLATE BOLT	98010244	11	5/16"-18 X 1"
C2	5/16" LOCK WASHER	98200159	11	5/16" LOCK WASHER
C3	PS FRONT TOP MOUNTING POST PLATE	48341001	1	
C4	PS FRONT BOTTOM MOUNTING POST PLATE	48341002	1	
C5	DS & PS REAR BOTTOM MOUNTING POST PLATE	48342101	2	
C6	MOUNTING WASHER	13070001	2	
C7	DS & PS REAR TOP MOUNTING POST PLATE	48342001	2	
*MOUNTING POST ASSEMBLY				
E1	1/4-20 BUTTON HEAD SCREW	98410241	1	1/4-20 X 1/2" LONG BHSCS
E2	1/4 FLAT WASHER	98250150	1	1/4" OVERSIZED FLAT WASHER
E3	MOUNTING POST HANDLE RAM	48353001	1	
E4	BAIL PIN	98410581	1	1/4" DIA. x 1 1/2" BAIL PIN
E5	SLOTTED NUT	98150121	1	1"-14 SLOTTED NUT
E6	DS FRONT BASE FOOT FLAT WASHER	98250100	1	1" USS FLAT WASHER
E7	MOUNTING POST	18050101	1	
E8	COTTER PIN	98410567	1	1/4" X 2" COTTER PIN

4900 SUPERLITE OEX EXPLODED VIEW

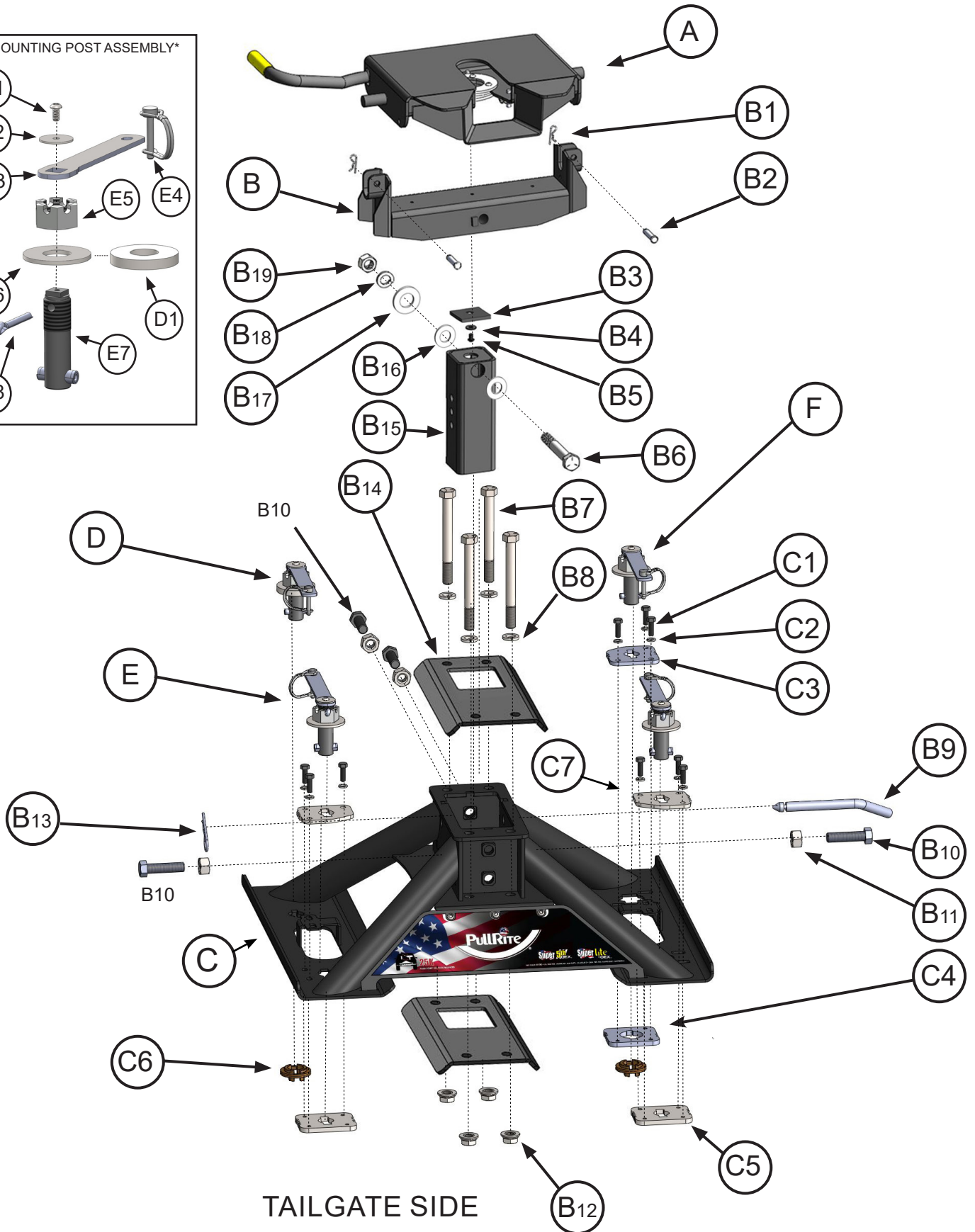
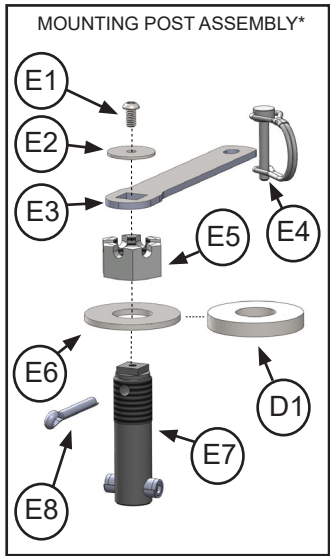

TAILGATE SIDE

#4900 PARTS LIST

	NAME	PART NO.	QTY	DESCRIPTION
A	HITCH PLATE ASSEMBLY	3601	1	
B	ROCKER ARM	4821	1	
C	GM OEX HITCH BASE	4730	1	
D	OEX DS FRONT MOUNTING POST KIT	49341	1	
E	OEX REAR MOUNTING POST KIT	49343	2	
F	OEX PS FRONT MOUNTING POST KIT	49342	1	
SUPER 5TH COUPLER KIT # 4820 (INCLUDES HITCH PLATE)				
B1	HITCH PIN CLIP	98410127	2	#3 13 GAUGE 1.63" OAL HITCH PIN CLIP
B2	CLEVIS PIN	98410111	2	1/2" X 2" CLEVIS PIN
B3	NEOPRENE SPRING	48210001	1	2" X 2" NEOPRENE RUBBER
B4	5/16" WASHER	98250160	1	5/16" FLAT WASHER
B5	BUTTON HEAD SCREW	98010273	1	5/16"-18 X 3/4" BHSCS
B6	ROCKER ARM BOLT	98010303	1	7/8"-9 X 6" HCS
B7	COLUMN LOCATION PLATE BOLT	98010304	4	5/8"-11 X 6" HCS
B8	COLUMN LOCATION PLATE LOCK WASHER	98200133	4	5/8" LOCK WASHER
B9	HITCH PIN	010019	1	5/8" DIA. X 4" HITCH PIN
B10	COLUMN SET SCREW	98010231	4	5/8"-11 X 1 1/2" TAP BOLT
B11	HEAVY HEX JAM NUT	98150176	4	5/8" - 11 HEAVY HEX NUT
B12	COLUMN LOCATION PLATE FLANGE NUT	98150200	4	5/8"-11 SERRATED FLANGE NUT
B13	PIN CLIP	98410143	1	
B14	COLUMN LOCATION PLATE	48142001	2	
B15	ROCKER ARM COLUMN	4822	1	
B16	NYLON WASHER	41030405	2	7/8" NYLON WASHER
B17	ROCKER ARM WASHER	98200175	1	7/8" WASHER
B18	ROCKER ARM LOCK WASHER	98200174	1	7/8" LOCK WASHER
B19	ROCKER ARM BOLT NUT	98150215	1	7/8" - 9 HEX NUT
BASE HARDWARE KIT #260204				
C1	COLUMN LOCATION PLATE BOLT	98010304	4	5/8"-11 X 6" HCS
C1	MOUNTING POST PLATE BOLT	98010244	11	5/16"-18 X 1"
C2	5/16" LOCK WASHER	98200159	11	5/16" LOCK WASHER
C3	PS FRONT TOP MOUNTING POST PLATE	47330003	1	
C4	PS FRONT BOTTOM MOUNTING POST PLATE	47330004	1	
C5	DS & PS REAR BOTTOM MOUNTING POST PLATE	47331001	2	
C6	MOUNTING WASHER	13070001	2	
C7	DS & PS REAR TOP MOUNTING POST PLATE	49330001	2	
*MOUNTING POST ASSEMBLY				
D1	DS FRONT TOP MOUNTING POST WASHER	47330001	1	WASHER FOR DRIVER SIDE FRONT MOUNTING POST
E1	1/4-20 BUTTON HEAD SCREW	98410241	1	1/4"-20 X 1/2" LONG BHSCS
E2	1/4 FLAT WASHER	98250150	1	1/4" OVERSIZED FLAT WASHER
E3	MOUNTING POST HANDLE RAM	48354001	1	
E4	BAIL PIN	98410581	1	1/4" DIA. x 1 1/2" BAIL PIN
E5	SLOTTED NUT	98150121	1	1"-14 SLOTTED NUT
E6	DS FRONT BASE FOOT FLAT WASHER	98250100	1	1" USS FLAT WASHER
E7	MOUNTING POST	18050101	1	
E8	COTTER PIN	98410567	1	1/4" X 2" COTTER PIN

5 YEAR LIMITED WARRANTY

PULLIAM ENTERPRISES, INC. hereinafter referred to as "PULLIAM", warrants to the first retail owner only, this PullRite towing system to be free from defects in materials and workmanship for a period of five (5) years or 31,068 miles (50,000 km) after the installation on purchaser's vehicle, whichever occurs first.

To validate this warranty, the first retail owner must mail the provided warranty card to PULLIAM, or register online at www.pullrite.com, within ten (10) days after installation of said towing system on his vehicle.

The owner is responsible for all normal and preventative maintenance described in the Owner's Manual.

If any defect occurs which the owner believes is covered by this warranty within said five (5) year period, the owner shall contact PULLIAM immediately, either in writing or by telephone call, Attention Customer Service Department. The owner will be instructed to return the hitch at his expense either to an authorized PullRite dealer or to PULLIAM to repair or replace any parts necessary to correct defects in material or workmanship.

Repair or replacement shall be at the sole option of PULLIAM and shall be completed by or on behalf of PULLIAM free of charge for materials and labor.

This warranty gives you specific legal rights, and you may also have other rights which vary from state to state.

THIS WARRANTY SPECIFICALLY *EXCLUDES* EACH OF THE FOLLOWING:

1. Defects in the product resulting from misuse, neglect, accident, loading beyond the vehicle's capacity, failure to comply with instructions contained in the Owner's Manual or unauthorized repairs, replacements, alterations or modifications. "Unauthorized repair, replacements, alterations" are those made without PULLIAM'S prior knowledge and consent.
2. Any incidental or consequential damage including, but not limited to, loss of use of the vehicle, towing charges, vehicle rental, loss of time, inconvenience, travel, gasoline, lodging and telephone expenses, loss of revenue and damages on account of personal injury and property damage. (Some states do not allow the exclusion or limitation of incidental or consequential damages, so these limitations may not apply to you).
3. Repairs or replacements of defects in any PullRite towing system, or part thereof, installed on any vehicle which has been rented, leased or used for any commercial purpose.
4. Any representation, warranty of undertaking made by any dealer or third party beyond the scope of the warranty herein expressed.
5. Any problem resulting in normal deterioration due to wear or exposure.

TO THE EXTENT PERMITTED BY LAW, IMPLIED WARRANTIES OF MERCHANTABILITY AND FITNESS FOR A PARTICULAR PURPOSE ARE LIMITED IN DURATION TO FIVE YEARS FROM THE DATE OF INSTALLATION ON THE FIRST OWNER'S VEHICLE. (SOME STATES, HOWEVER, DO NOT ALLOW LIMITATIONS AS TO DURATION OF IMPLIED WARRANTY, SO THOSE LIMITATIONS MAY NOT APPLY TO YOU).



Product Warranty Registration

As an owner of a PullRite product, you must register your product to be considered for warranty coverage. See Owners Manual for further details.

Please note, that you can also register online at www.pullrite.com/warranty.htm.

Name: _____

Address: _____

City: _____ State: _____ Zip: _____

Email Address: _____

Phone (optional): _____

Purchase Price: _____ Date of Purchase: _____

Dealer's Name: _____

Dealer's Address: _____

Dealer's City: _____ Dealer's State: _____ Dealer's Zip: _____

Dealer's Phone: _____

Model Purchased: _____

Vehicle Make: _____ Vehicle Model: _____ Vehicle Year: _____

Vehicle Year: _____ Vehicle Cab Style: _____ Vehicle Bed Length: _____

Did you receive an Owners Manual from the Dealer? Yes / No

What influenced you to buy your hitch? _____

Comments:



MANUFACTURED BY:

PULLIAM ENTERPRISES, INC.
13790 East Jefferson Blvd.
Mishawaka, IN 46545
(574) 259-1520 • (800) 443-2307
info@pullrite.com • www.pullrite.com