

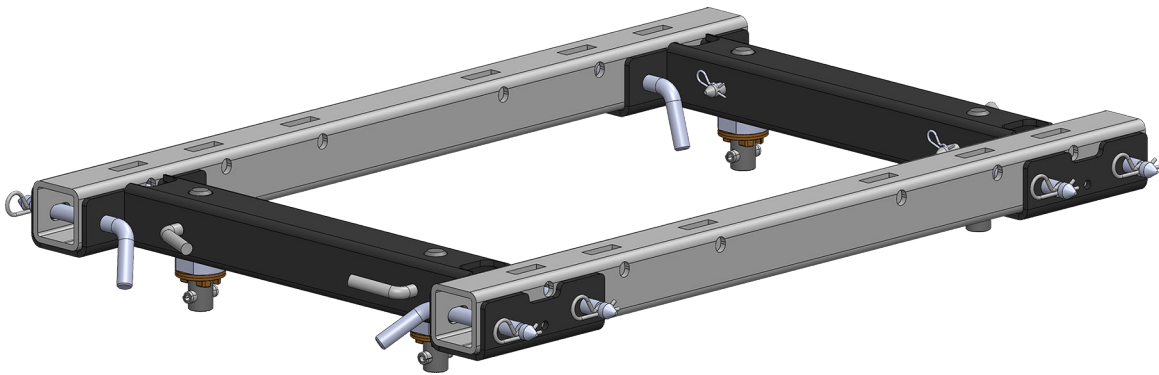

FORD

20K OE Series Industry Standard Adapter

#4442



Gross Trailer Weight (Maximum).....20,000 lbs.

Vertical Load Weight (Max. Pin Weight).....4,500 lbs.

SYSTEM TOW CAPACITY

Please note, in order to determine the **total tow capacity** of a system, you must consider the weight ratings of each component in that system. This includes, but may not be limited to, the capacity/rating of the **tow vehicle**, the **fifth wheel hitch**, and the hitch's **mounting system**. Actual tow capacity of the system will be equal to the lowest rated component.

Installation Instructions

SPECIFICATIONS

- Fits 2010-2020 Ford F250, F350 & F450 with Fifth Wheel/Gooseneck OE Tow Prep Kit
 - ISR mounting rails are located center of the axle
 - SAE J2638 tested and rated to 20K capacity

ADAPTER KIT EXPLODED VIEW & PARTS LIST

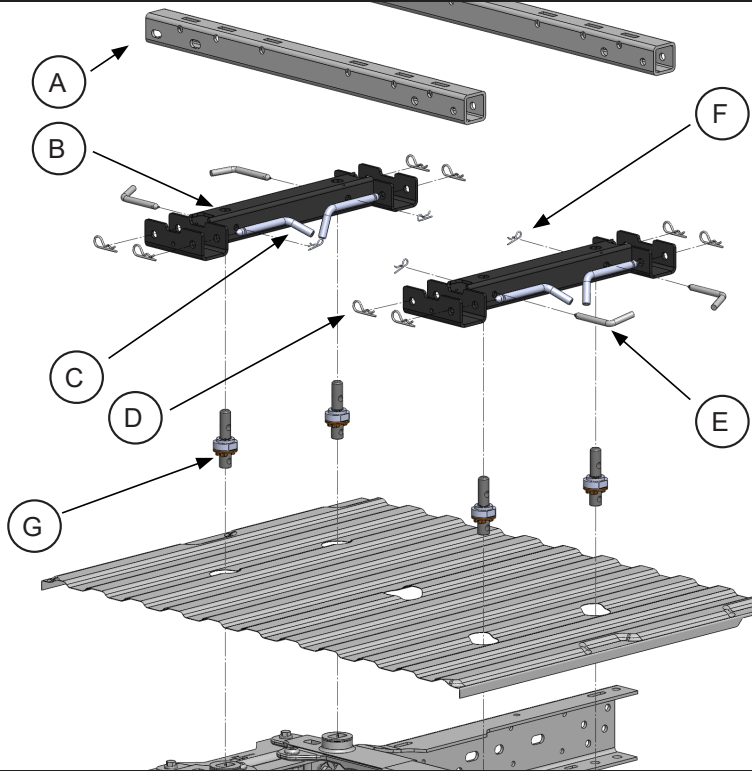

| #4442 FORD OE SERIES ADAPTER KIT | | | |
|----------------------------------|---------------------------------------|----------|------|
| item | description | part no. | qty. |
| A | FORD OE SERIES BASERAIL | 444203 | 2 |
| B | BASERAIL SIDE SUPPORT | 444201 | 2 |
| C | STANDARD SHACK PIN | 010019 | 8 |
| D | HITCH PIN CLIP | 98410143 | 4 |
| E | BASERAIL PIN | 08060001 | 4 |
| F | PIN CLIP | 98410127 | 4 |
| G | FORD OE SERIES MOUNTING POST ASSEMBLY | 444204 | 4 |

| #444204 MOUNTING POST ASSEMBLY (pre-assembled from factory) | | | |
|--|-------------------|----------|------|
| item | description | part no. | qty. |
| H | MOUNTING POST NUT | 44420402 | 1 |
| I | MOUNTING WASHER | 13070001 | 1 |
| J | MOUNTING POST | 44420401 | 1 |

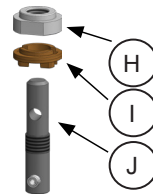

INSTALLATION

NOTE: Factory installed towing prep kits installed by the manufacturer are not perfectly square to the vehicle's frame and may not be parallel to the back of the cab. To account for these variations in manufacturing, our baserails include an obround hole on each end to account for these tolerances, but in rare cases, may not allow the hitch to fit into the baserails properly.

The basic steps of this installation is as follows:

- Install mounting post assemblies
- Install the base rails to the mounting posts
- Install your PullRite fifth wheel hitch

This adapter works with any PullRite ISR Series hitch or any other manufacturer's ISR-style hitch.

Detailed Installation Instructions

1. Insert a Mounting Post Assembly {G} into each mounting post location (figure 1).
2. Rotate each Mounting Post Assembly 90° or give ¼ of a turn (figure 2).
3. Lightly tighten the Mounting Post Nuts {H} down by hand, securing the posts into position (figure 3).
4. Place both Baserail Side Supports {B} onto the Mounting Posts in their correct orientation, and secure in place using the 1/2" hitch pins {E} and pin clips {F} (figure 4).
5. Place a Baserail {A} into each Baserail Side Support (figure 5). (Note there is a set of round holes on one end of each baserail, and a set of obround holes on the other end. You should match both baserail orientations in the bed with the obround holes on the same side of the truck bed).
6. Place two Standard Shack Pins {C} through each Baserail Side Support and Mounting Post, and lock each Baserail {A} into place with a Pin Clip {D}.
7. Set your fifth wheel hitch in the corresponding mounting locations and secure with 1/2" hitch pins and clips included with your hitch.
8. Hand tighten each Mounting Post Nut {H} down firmly.

