

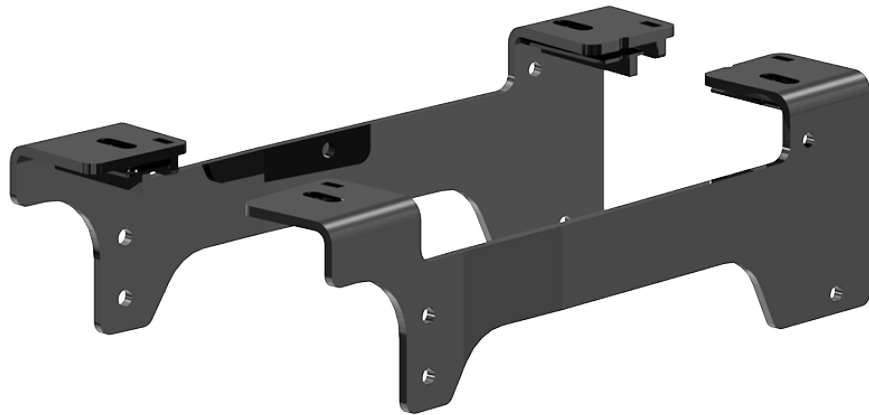

CHEVY/GMC 2500-3500

20K Industry Standard Rail Custom Mounting Kit

#2770



Gross Trailer Weight (Maximum).....20,000 lbs.
Vertical Load Weight (Max. Pin Weight)5,000 lbs.

SYSTEM TOW CAPACITY

Please note, in order to determine the total tow capacity of a system, you must consider the weight ratings of each component in that system. This includes, but may not be limited to, the capacity/rating of the tow vehicle, the fifth wheel hitch, and the hitch's mounting system. Actual tow capacity of the system will be equal to the lowest rated component.

Installation Instructions

SPECIFICATIONS

- Fits 2020 Chevy/GMC 2500-3500 pickup with and without overload brackets.
- King pin is located three inches ahead of the axle.

TABLE OF CONTENTS

PREPARATION / BRACKET NUT TAB.....	3
MOUNTING KIT EXPLODED VIEW.....	4
MOUNTING KIT PARTS LIST.....	5
MARKING THE TRUCK BED FOR DRILLING.....	6
LAYOUT METHOD.....	6
TEMPLATE METHOD.....	7
INSTALLATION.....	8
PART 1 — PLACEMENT & BED HOLE LOCATIONS.....	8
PART 2 — BRACKET INSTALLATION.....	9
PART 3 — HITCH ALIGNMENT.....	10
PART 4 — FINAL INSTALLATION PROCEDURES.....	10

PLEASE VISIT OUR YOUTUBE CHANNEL
FOR PRODUCT VIDEOS

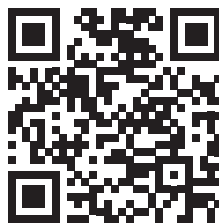

<https://www.youtube.com/user/pullritevideo>

PREPARATION

1. Remove the hitch from the shipping carton and check the part quantities using the Parts List on page 5.
2. Block vehicle wheels. Some vehicles may require you to raise the rear of the truck in order to make it easier to drill for installing the mounting brackets on the truck frame.
3. You may wish to remove the wheels to give yourself greater working room.
4. Read all instructions.

ISR RAILS

This PullRite mounting kit is designed to be used with ISR rails. ISR or Industry Standard Rails are a universal hitch mounting rail system used in the RV industry. Once installed, the ISR can be a cost-effective way to replace or upgrade your hitch without having to install new rails and bracket kit.

Note: Your tow package is only as strong as its weakest link, therefore If you have a 24K hitch in your truck on a 20K rail system, you can only safely tow a 20K trailer.

BRACKET NUT TAB

The Bracket Nut Tabs are a feature built into PullRite mounting brackets. They hold the 5/8" flange nuts locked in place, making it easier to install the rail kit. It eliminates the need for a wrench on the nut when tightening down the rail bolts. The bracket and tab both feature an oblong slot which allows for some tolerance left to right when installing the rails.

Instructions for the (4) tabs are as follows:

1. Bend open the tabs by pulling down with hand or pliers. (Fig. 1)
2. Place 5/8" flange nut face up to oblong slot in bracket. Make sure nut is firmly seated in the tab. (Fig. 2)
3. Bend tab back into place with nut inside. (Fig. 3)

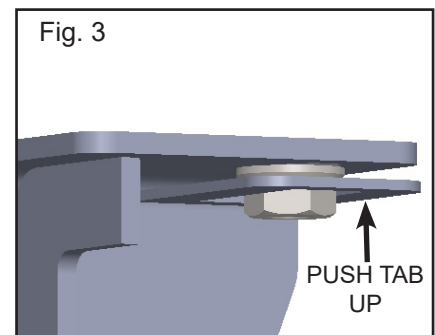
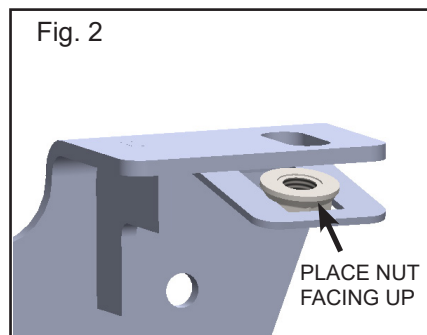
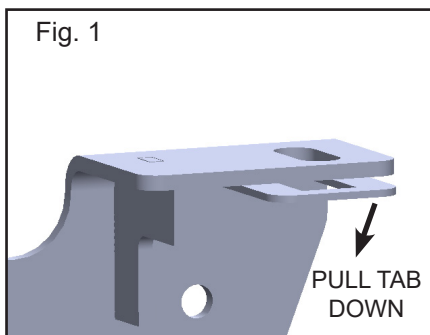

MOUNTING KIT EXPLODED VIEW

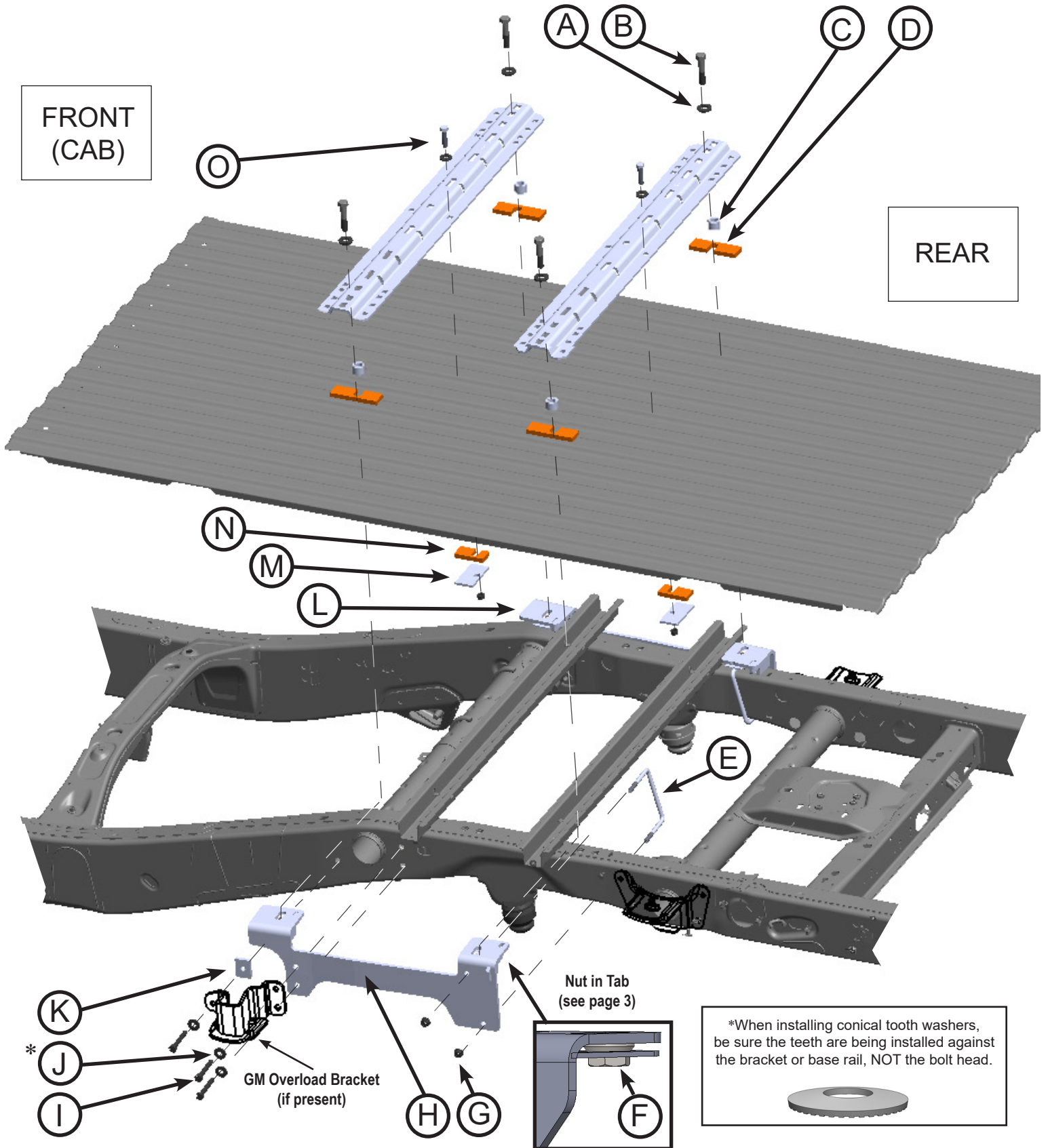

PARTS LIST

#2770 ISR CUSTOM MOUNTING KIT

Item	Description	Part No.	Qty.	Material
A	* CONICAL SERRATED WASHER	98200171	4	5/8" X 1 1/2" EXT TOOTH CON WSHR
B	BASE RAIL BOLT	98010217	4	5/8-11 X 3" HEX BOLT GR 5
C	SPACER TUBE	27210204	2	.88 ID X 1.25 OD X .22 THK
D	LARGE SHIM	27670116	4	LEXAN MATERIAL
E	1/2" U-BOLT	98050181	2	1/2" X 5 3/8" X 4.41 U-BOLT
F	5/8"-11 SERRATED FLANGE NUT	98150200	4	5/8"-11 SERRATED FLANGE NUT ZIN
G	1/2"-13 SERRATED FLANGE NUT	98150201	10	1/2"-13 SERRATED FLANGE NUT ZINC
H	DS MOUNTING BRACKET	27710101	1	DRIVER SIDE BRACKET
I	M12 HEX BOLT	98010113	6	.M12 - 1.75 X 90MM
J	* CONICAL SERRATED WASHER	98200172	8	.531 ID X 1.25 OD X .144 THK GR5 ZN
K	OVERLOAD SPACER	27710002	2	.53 ID X 2.13 L. X 1.63 W. X.38 THK
L	PS MOUNTING BRACKET	27710102	1	PASSENGER SIDE BRACKET
M	CENTER LINE BACK-UP PLATE	05070303	2	.53 ID X 4.00 L. X 2.00 W. X..25 THK
N	SMALL SHIM	27670117	2	LEXAN MATERIAL
O	CENTER LINE BASE RAIL BOLT	98010175	2	1/2"-13 X 2" HEX CAP SCREW GR 5
*P	ANTI-ROTATION BOLT	44270401	4	MODIFIED 1/2"-13 X 1 1/2" HEX BOLT

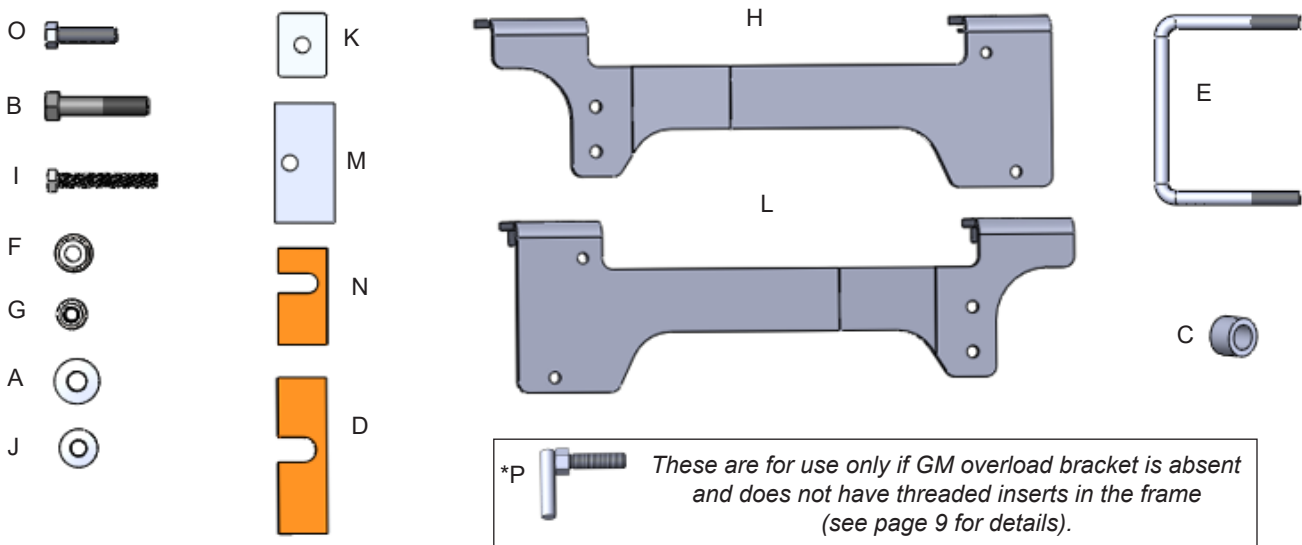

MARKING THE BED FOR DRILLING

LAYOUT METHOD

If you purchased an installation template, please proceed "Template Method." Templates are sold separately.

1. Referencing "Truck Bed Dimension Table" below, measure and mark from the back of the bed forward, the values for "A" and "B". Do this at any point on both sides of the bed.
2. Draw a line across the bed from mark to mark.
3. Find the centerline of the bed.
4. Draw a line down the middle of the bed from front-to-rear.
5. Center the measurement of "C" across the center line at the front-most line you made in step 2 and mark the measurement on each side (parallel to the center line). This will locate the 4 drill holes.

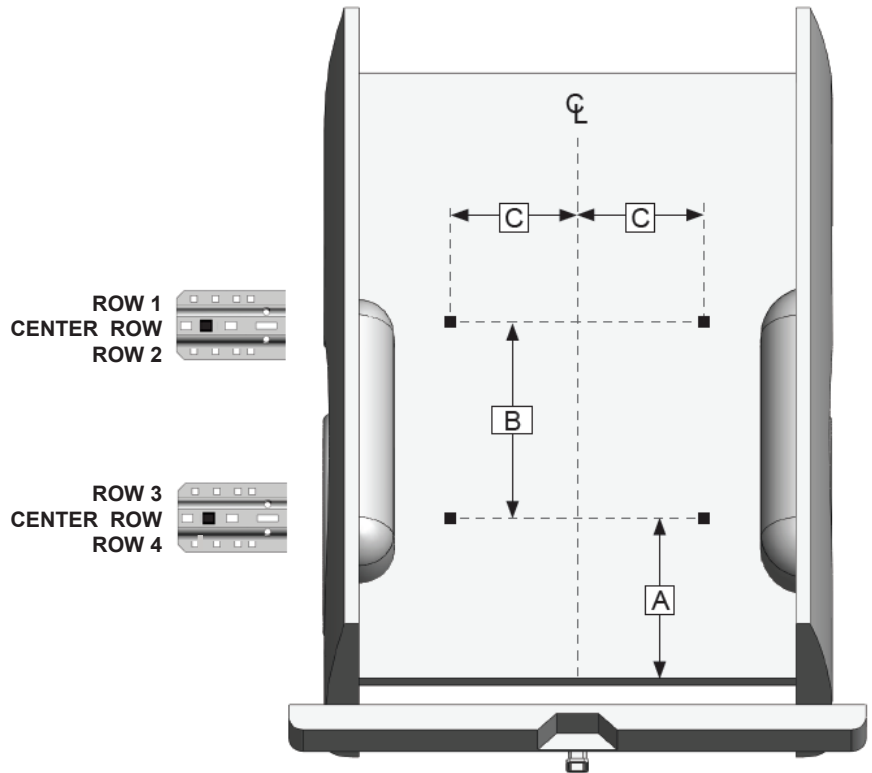

NOTE: *The center line bolts will not be marked at this time unless using the template method. They should be attached after both rails are set (see page 10).*

TRUCK BED DIMENSION TABLE					
BED LENGTH	LAYOUT METHOD			TEMPLATE METHOD	
	"A"	"B"	"C"	"X"	TEMPLATE PART#
6'6"	34 3/4"	22"	19 7/16"	31-7/8"	27200000
* 8'	37 3/4"	22"	19 7/16"	34-7/8"	27200000

* Before drilling bed holes - validate measurements with chassis mounted bracket (see steps 1- 4 on page 8).

TEMPLATE METHOD

1. Lay the template in the truck bed, centering it from side-to-side, and parallel to the end of the truck bed using the dimension "X" listed below (Fig.5).
2. Mark the 4 holes as indicated below, making sure the template does not move (see Installation Tip).

INSTALLATION TIPS: The *TEMPLATE* should be orientated as shown in the drawing below. To avoid drilling holes in error from out of tolerance bed-to-frame dimensions, mark the hole locations as lightly as possible if a center or transfer punch is used. Then use a very small diameter drill bit to drill a location on one side of the bed. Place the Mounting Brackets against the frame to determine the correctness of the bed hole locations relative to the pre-punched holes in the Mounting Bracket and existing frame holes. Use transparent tape to cover the mounting hole on the top of each mounting bracket (when the pilot hole is drilled through the bed, the tape will be pierced by the small drill; which should be positioned in the center of the mounting bracket hole). The template has a tendency to move when placed on the slick paint of new truck beds, and it may be helpful to place a small piece of NON-SKID matting, such as "SCOOT-GARD"™ or simply use duct tape on each corner to help keep the template from moving.

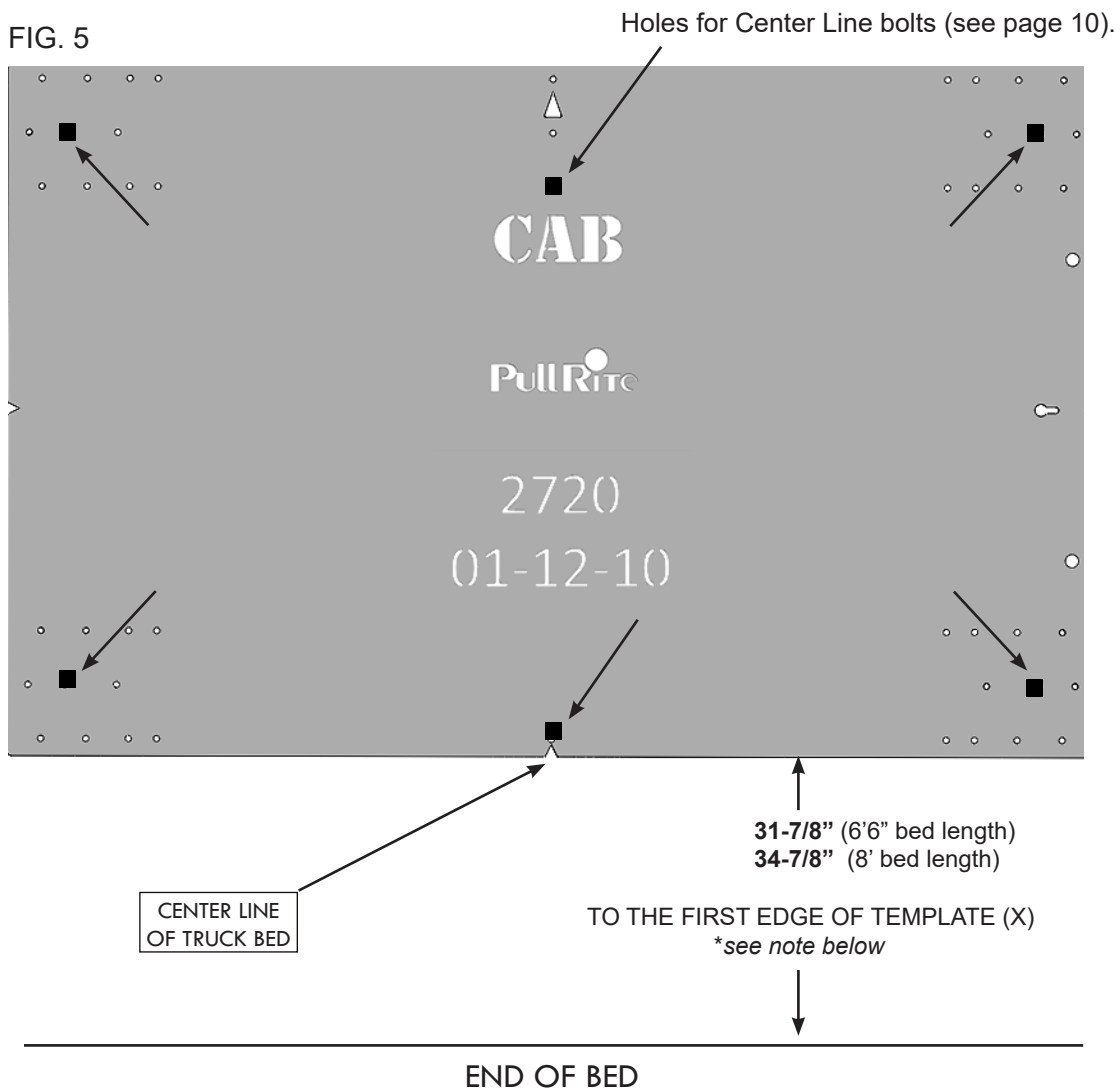

***NOTE:** To insure accuracy of bed holes, follow all steps on pages 8-9 before drilling into the truck bed.

INSTALLATION

Mounting Bracket Installation

Part 1: Bracket Placement & Bed Hole Locations

Since most truck beds are not installed square to the frame or are the same distance from the back of the cab, the installer will need to make sure the bed holes line up properly with the center of each frame bracket mounting hole by following the instructions below.

Detailed Installation Instructions

NOTE: There are two possible installation variations, one with the GM overload bracket present, and one without. Use the Overload Spacer only if GM overload bracket is present.

1. Use transparent tape to cover the mounting hole on the top of each mounting bracket (when the pilot hole is drilled through the bed, the tape will be pierced by the small drill; which should be positioned in the center of the mounting bracket hole).
2. Use the threaded holes on the truck frame to hand tighten the front side of the Mounting Bracket to the truck frame with the provided M12 bolts (FIG.6). If a GM overload bracket is present, pull out the bolts holding the GM overload bracket and place Mounting Bracket flush to the truck frame. Insert the M12 bolts and hand tighten. Set aside GM overload bracket until after "Drilling the Bed" procedures (page 9) when the Mounting Bracket is ready to torque down permanently.
3. Use a clamp to fasten the bracket to the truck frame and remove the M12 bolts.
4. Drill the first 1/16" pilot hole through the truck bed over the rear mark on the driver side where you made the mark during the "Marking Bed for Drilling." The bit should come down through the bracket hole, piercing the transparent tape, aiding the centering of the bracket front-to-rear and side-to-side.
5. If the pilot hole is off-center to the bracket hole, remember to adjust **all** the pilot hole locations accordingly.

FIG.6

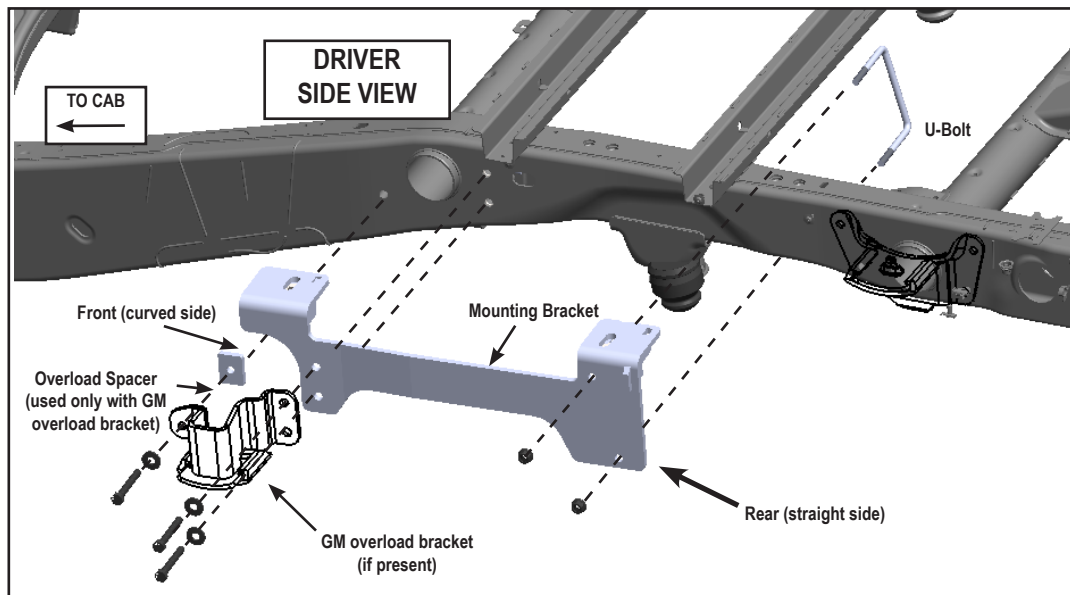

INSTALLATION

NOTE: Some truck beds are not installed square on their frame by the manufacturer. To ensure your pilot holes are aligned properly, it is important that you use the measurements provided only as a starting point and make adjustments as needed.

Once you have one pilot hole centered, you will use this hole as a point of reference for all remaining pilot hole adjustments. If you are using the Template Method, simply use the properly drilled hole as a pivot point to square the remaining holes to the frame. If you are using the Layout Method, you may accomplish the same thing by using a framing square and straight edge.

6. Repeat steps for the passenger side mounting bracket, checking carefully for proper centering.

NOTE: Final bed hole placement is dependent on the fixed position of the brackets, due to the fixed location of the front bracket holes in the frame.

WARNING: Before proceeding to "Part 2, "Drilling the Bed...", you must verify that each pilot hole is centered left to right over the hole on each mounting bracket before the larger bolt holes are drilled through the bed.

Part 2: Drilling the Bed & Bracket Installation

1. Remove the mounting brackets and use a 3/4" drill centered over the 1/16" pilot hole and drill through the truck bed.
2. De-bur the inside of the drilled bed holes.

Bracket Installation

1. Replace and fasten the mounting brackets to the frame with the M12 Bolts. If GM overload brackets are present, use the Overload Spacer flush to frame and place GM overload bracket over the Overload Spacer & Mounting Bracket and insert M12 bolts and hand tighten (See Fig.7).
2. Fasten the 1/2" U-Bolt around truck frame so that the threads go outward through the holes in the rear (straight side) of the Mounting Bracket. Fasten with 1/2" serrated nuts. Tighten all bracket fasteners using the torque table on page 10. Repeat operation for both Mounting Brackets.

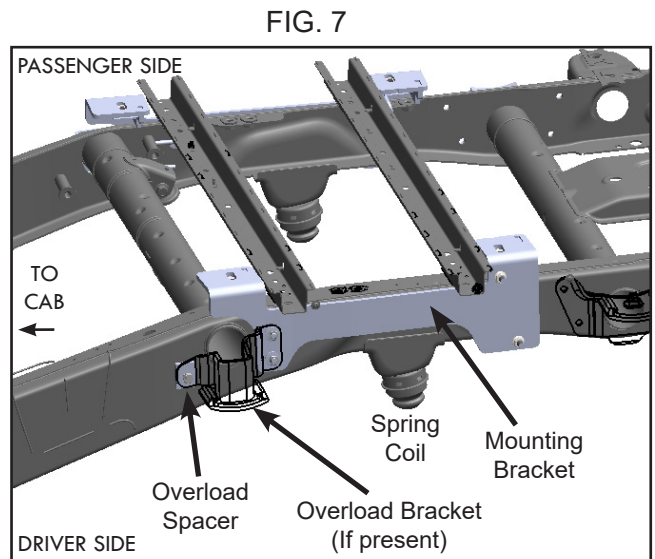

NOTE: Use a hand wrench to tighten the flange nut onto the bolts. DO NOT use an impact wrench, this can easily strip the connection.

Anti-Rotation Bolts

Some truck frames that do not have the GM overload bracket are also missing the corresponding threaded inserts inside the truck frame. In this instance, use the included Anti-Rotation Bolts to attach the bracket to the truck. It can be tricky to install these because they must be placed inside the truck frame with threads protruding through the bracket holes. Also included in this kit are Bolt Leaders (FIG A) to aid in directing the bolts through the truck frame.

To install, it may be helpful to use a separate piece of wire fashioned into a hook to fish through the bracket holes to exit the obround hole. Use tape to attach the wire to the Bolt Leader. Insert the bolt threads into the coiled end of the leader and pull wire and leader through the obround hole. Pull into the bracket hole until the bolt threads are protruding (FIG B). Repeat with lower bolt. Position the bracket and slide the bracket over the bolt leaders and bolt threads until bracket is flush to the frame. Remove coiled end of leader from the bolt threads being careful not to push threads back into the frame. Hold tension on the bolt while tightening the flange nut. Tighten according to the Torque Table on page 10.

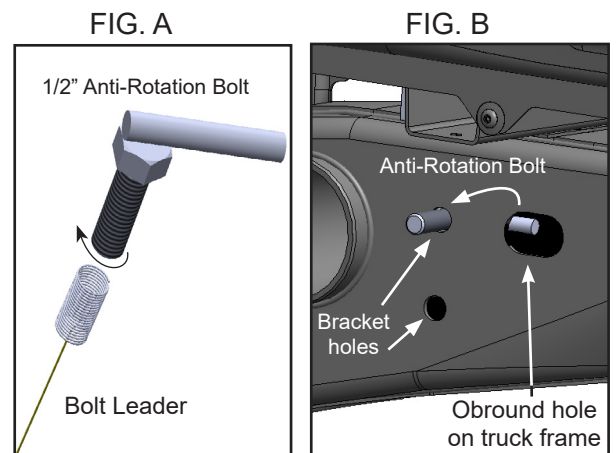

INSTALLATION

Part 3: Hitch Alignment

1. Install ISR rails onto the truck bed. Use the supplied 5/8" x 3" bolt placing it first through the Conical Washer (teeth down) and the rail into the Tube Spacer under the rail, and into the drilled bed hole.
2. Align nut with pencil or drift pin. If needed, add the Large Lexan Shim between the Tube Spacer and the top of the truck bed (see Fig. 8). Hand tighten the (4) bolts into the 5/8" Flange Nuts seated in the mounting bracket nut tabs.

Part 4: Install Center Line Bolts

1. Add the Center Line Bolts on the rails after the rails are installed. These bolt locations will have been marked if the template was used. If not already marked, match drill the center holes on the flush edge of the rails closest to the tailgate into the truck bed (see the locations shown on FIG.9).
2. Configure the Center Bolt, Conical Washer (teeth down), Small Lexan Shim, and Backing Plate as shown in FIG.10. Tighten the (2) 1/2" Bolts with Flange nuts according to the torque table below.

Part 5: Final Installation Procedures

1. Place the hitch spades into ISR rail slots and install the hitch pins and clips to secure the hitch frame to the rails. Tighten 5/8" bolts according to the Torque Table below.
2. Make sure the hitch spade can be set down in rail slots without binding. You may need to loosen the bolts on the rails if binding occurs. Adjust as needed and re-tighten the bolts.

FIG. 8

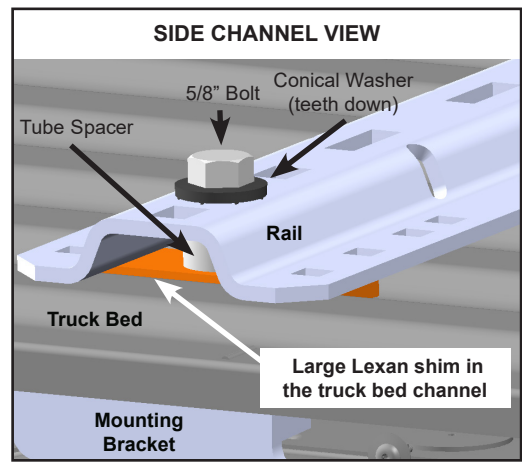

FIG. 9

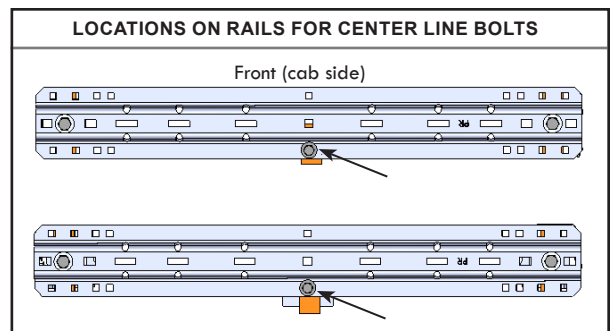
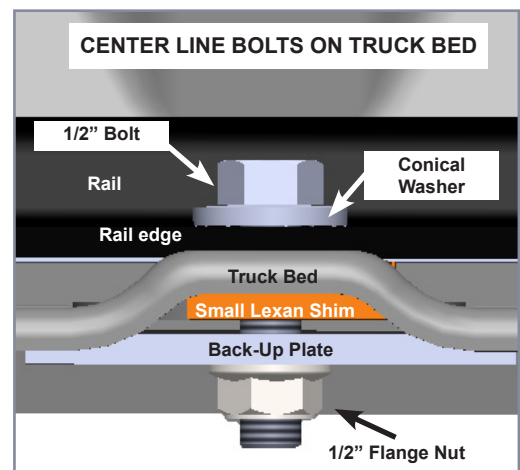

FIG. 10



TORQUE TABLE	
3/8" Bolt	31 ft. lbs.
1/2" Bolt	75 ft. lbs.
5/8" Bolt	151 ft. lbs.
3/4" Bolt	266 ft. lbs.



MANUFACTURED BY:

PULLIAM ENTERPRISES, INC.
13790 East Jefferson Blvd.
Mishawaka, IN 46545
(574) 259-1520 • (800) 443-2307
info@pullrite.com • www.pullrite.com