

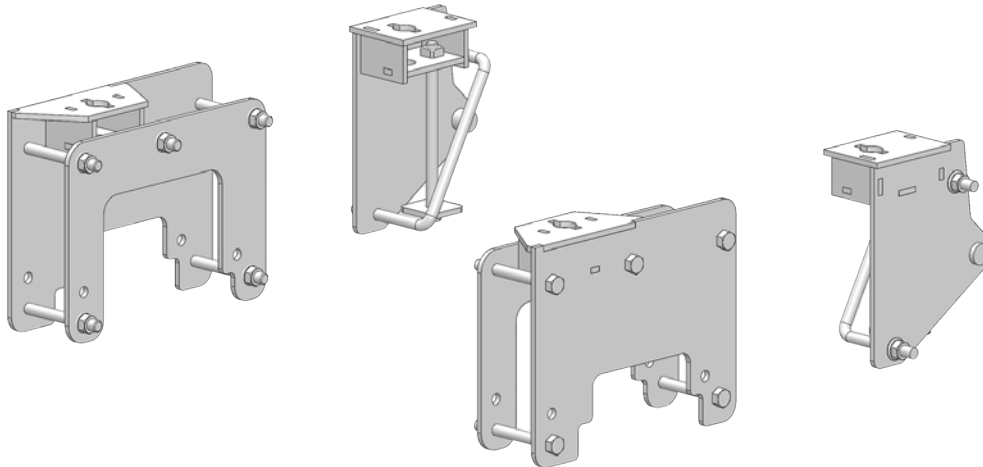

DODGE

SuperRail Custom Mounting Kit

#4440



HITCH OPTION(S)	GROSS TRAILER WEIGHT (MAX)	VERTICAL LOAD WEIGHT (MAX PIN WEIGHT)
#4100 16K SuperGlide	16,000 lbs.	4,000 lbs.
#4400 20K SuperGlide	20,000 lbs.	5,000 lbs.

Installation Instructions

SPECIFICATIONS

- Fits 2013 Dodge 2500
- Not recommended for trailers over 96" wide
- 96" wide trailers -- trailer king pin must be at least 2" *forward* of the leading edge of the trailer
 - Hitch is located center of axle
- SuperRail Bracket Kit (Bracket & Hardware) #4441

IMPORTANT

DO NOT OPERATE HITCH UNTIL YOU READ THIS SECTION!

1. The SuperGlide hitch was designed to allow the Turntable Cam Arm Assembly to “glide” along two metal tubes, called the Way Tubes. Since its release in 1998, we have made several advancements in the design, strength, and durability of these components. The Lubrication section of your Owners Manual spans several product releases and design changes. It is *imperative* that you read each section and determine which SuperGlide hitch you purchased, and how to care for it. There have been three major lubrication changes to the SuperGlide hitch:
 - Prior to April 2008, Way Tubes were assembled with either a conventional, quality grade grease or none at all
 - In April 2008, we started coating the Way Tubes with a graphite-based spray lubricant called SlipPlate™
 - November 2009 brings a new innovation from PullRite Towing Systems with the use of plastics. The Turntable Cam Arm Assembly is now equipped with Plastic Wear Plates; see Owners Manual for details (not available for #3600 models)

Depending on when your hitch was manufactured, the Way Tubes of your new SuperGlide hitch will meet one of the above criteria. Each application listed requires some level of maintenance, so it is important that you read the following instructions carefully for the correct lubrication instructions.

Failure to properly lubricate the Way Tubes, as directed in this section, will eventually cause galling between the metals of the Way Tubes and Cam Arm Assembly, which will result in hitch failure. Destruction of various hitch parts is also likely, as well as truck and/or trailer damage, and will not be covered under the Manufacturer’s Warranty.

2. **THE TRAILER’S KING PIN BOX MUST BE EQUIPPED WITH A CAPTURE PLATE (UNIVERSAL OR QUICK CONNECT) TO ALLOW THE HITCH TO FUNCTION (MUST BE PURCHASED SEPARATELY). NOTE: IF YOU HAVE PURCHASED A QUICK CONNECT CAPTURE PLATE AND DID NOT RECEIVE INSTRUCTIONS, THEY ARE AVAILABLE ONLINE, OR YOU CAN CONTACT PULLRITE CUSTOMER SERVICE AT (800) 443-2307.**
3. Failure to modify the length of the brake away cable that activates the emergency braking of your trailer, may cause the cable to catch on protruding parts of the hitch. Resulting damage will not be covered by the manufacturers warranty.
4. There should be a minimum of 6” between the truck bed rails and the under side of the trailer for side tilt clearance. It is the customers responsibility to adjust the trailer king pin box for the appropriate amount of clearance.

NOTE: Some truck models are being manufactured with higher bed sides, making it necessary to adjust the height of your trailer’s king pin box. If you don’t have enough height adjustment available, PullRite produces a 3” Lift Kit that attaches to the rails of your #3100 (ask for part #3108) or #4100, #3300 and #4400 (ask for part #4408; *rated only for 18K when used with model #4400*) SuperGlide models.
5. Some truck beds have contoured bed sides, making the inside bed measurement narrower. Make certain the trailer’s king pin box does not contact the inside edge of the bed.
6. Trucks with bed liners may need a tall Mounting Post. See “NOTE” under “Drilling the Bed” for further details.
7. It is the installers and customers responsibility to ensure there is proper clearance between the truck and trailer. There should be a minimum of 2” of clearance as the trailer passes the cab. Call PullRite technical support with trailer width, make and year of truck and distance the king pin is from leading edge of the trailer (See “Caution” section, in the SuperGlide Owners Manual, for measuring procedure) at (800) 443-2307.
8. Read these instructions completely and follow them accurately. Should you have any questions, please call Customer Service at (800) 443-2307 prior to installation for assistance. *If you did not receive your Owners Manual, visit us online at www.pullrite.com or call the number above.*
9. The SuperGlide was designed for short bed pickup trucks. The hitch may function in a longer bed truck, but no mounting brackets exist to make the transfer. Some #4100 and #4400 mounting kits may transfer with modification.

TABLE OF CONTENTS

MOUNTING HARDWARE PARTS IDENTIFICATION	4
PARTS LIST	5
TRUCK PREPARATION	6
MARKING THE BED FOR DRILLING	6
LAYOUT METHOD	6
TEMPLATE METHOD	7
INSTALLATION	8
PART 1: BRACKET PLACEMENT & BED HOLE LOCATIONS.....	8
PART 2: DRILLING THE BED & BRACKET INSTALLATION	10
REAR MOUNTING BRACKET INSTALLATION	10
FRONT MOUNTING BRACKET INSTALLATION.....	10
PART 3: HITCH ALIGNMENT.....	11
PART 4: FINAL INSTALLATION PROCEDURES	11

MOUNTING HARDWARE PARTS IDENTIFICATION

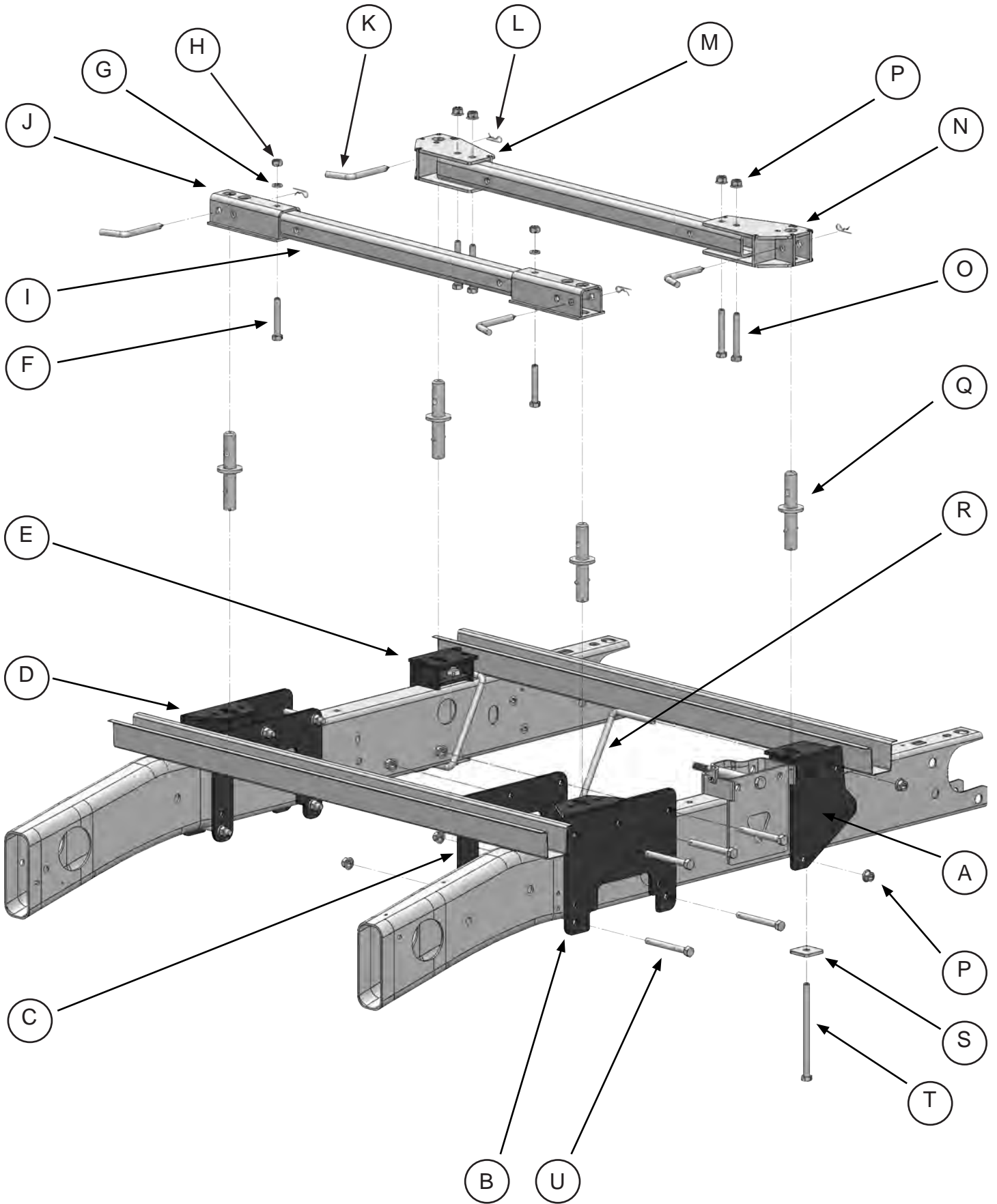

PARTS LIST

#4440 SUPER RAIL MOUNTING KIT

item	description	part no.	qty	material
	MOUNTING BRACKET KIT	4441	1	(See kit contents listed below)
I	BASE RAILS	33070001	2	2" SQ. X 1/4" WALL TUBING
J	BASE RAIL EXTENSIONS	330702	2	2-1/2" TUBE ASSEMBLY
M	PASSENGER SIDE OFFSET B.R. EXTENSION	444106	1	
N	DRIVER SIDE OFFSET B.R. EXTENSION	444105	1	

#4441 — MOUNTING BRACKET KIT

item	description	part no.	qty.	material
A	DRIVER SIDE REAR MOUNTING BRACKET	444103	1	
B	DRIVER SIDE FRONT MOUNTING BRACKET	331901	1	
C	FRONT BRACKET BACKUP PLATES	33190501	2	
D	PASSENGER SIDE FRONT MOUNTING BRACKET	331902	1	
E	PASSENGER SIDE REAR MOUNTING BRACKET	444104	1	
	MOUNTING BRACKET HARDWARE KIT	444107	1	(See kit contents listed below)

#444107 — MOUNTING BRACKET HARDWARE KIT

item	description	part no.	qty.	material
F	1/2" BASE RAIL BOLTS	98010183	2	1/2" - 13 X 3" HHCS GRD 5
G	1/2" BASE RAIL LOCK WASHERS	98200142	2	1/2" LOCK WASHER
H	BASE RAIL NUTS	98150153	2	1/2"-13 HEX NUT
K	BASE RAIL PINS	08060001	4	1/2" ROUND
L	PIN CLIPS	98410127	4	#3 PIN CLIP
O	3-1/2" BASE RAIL BOLTS	98010187	4	1/2"-13 X 3-1/2" HHCS GRD 5
P	1/2" FLANGE NUT	98150201	18	1/2"-13 SERRATED FLANGE NUT
Q	MOUNTING POSTS	330701	4	
R	U-BOLT	98050183	2	1/2"-13 X 4-3/4" X 7-5/8" U-BOLT
S	2" BACKUP PLATE	44410001	2	2" X 2" PLATE
T	7" REAR BRACKET BOLTS	98010214	2	1/2"-12 X 7-1/2" HHCS GRD 5
U	4-1/2" BOLTS	98010195	10	1/2"-13 X 4-1/2" HHCS GRD 5

LAYOUT TEMPLATE

description	part no.	qty.	material
LAYOUT BED TEMPLATE	44400000		ITEM SOLD SEPARATELY

TRUCK PREPARATION

1. Check part quantities using the Parts List.
2. Block vehicle wheels. Some vehicles may require you to raise the rear of the truck in order to make it easier to drill for installing the mounting brackets on the truck frame.
3. You may wish to remove the wheels to give yourself greater working room.
4. Carefully remove the plastic inner wheel well guards on both sides of the vehicle.
5. Remove the spare tire.
6. If you have purchased a template, proceed to the "Template Method" below; otherwise, begin with the "Layout Method."

MARKING THE BED FOR DRILLING

LAYOUT METHOD

If you purchased an installation template, please proceed "Template Method." Templates are sold separately.

1. Referencing "Truck Bed Dimension Table" below, measure and mark from the back of the bed forward, the values for "A" and "B". Do this at any point on both sides of the bed.
2. Draw a line across the bed from mark to mark.
3. Find the center line of the bed.
4. Draw a line down the middle of the bed from front-to-rear.
5. Center the measurement of "C" across the center line at the rear-most line you made in step 2 and mark the measurement on each side (parallel to the center line).
6. Center the measurement of "D" for the front-most line made in Step 2, and again mark the measurement on each side (parallel to the center line). This will locate the 4 drill holes.

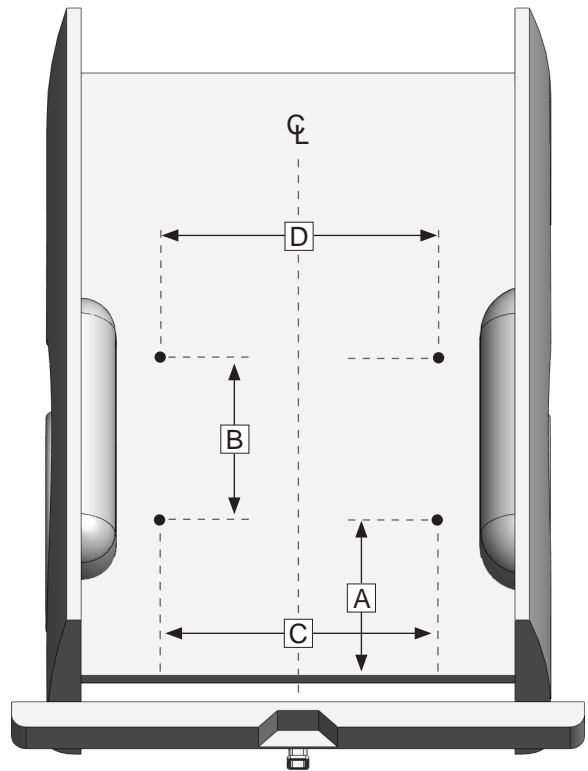

TRUCK BED DIMENSION TABLE					
LAYOUT METHOD				TEMPLATE METHOD	
"A"	"B"	"C"	"D"	"X"	Template part#
20-1/2"	23-1/16"	39"	39"	19-1/2"	44400000

TEMPLATE METHOD

1. Lay the template in the truck bed, centering it from side-to-side, and parallel to the end of the truck bed using the dimension "X" listed in "Truck Bed Dimension Table."
2. Mark the 4 holes, while making sure the template does not move.

NOTE: The TEMPLATE should be orientated as shown in the drawing below. Notice that the spacing of the forward and rearward facing holes may be different, and can be used to determine the correct orientation of the template. Item "C" in the table below shows the forward facing dimension, and Item "D", the rearward facing dimension. Note also, the information etched into the template — the direction of the cab, the template number and the revision date.

INSTALLATION TIP: The template has a tendency to move when placed on the slick paint of new truck beds, and it may be helpful to place a small piece of NON-SKID matting, such as "SCOOT-GARD"™ or simply use duct tape on each corner to help keep the template from moving.

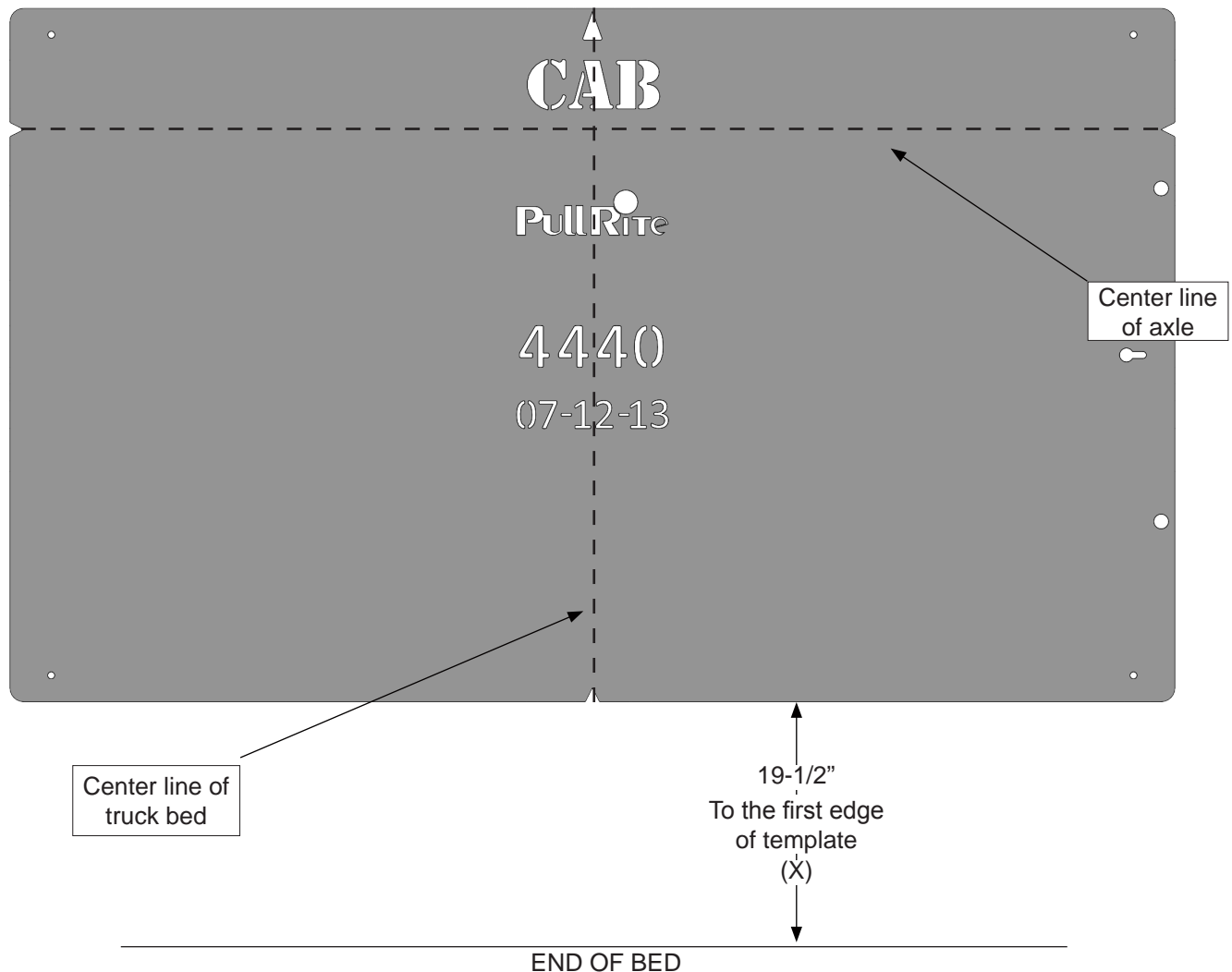

INSTALLATION

PART 1: BRACKET PLACEMENT & BED HOLE LOCATIONS

Since most truck beds are not installed square to the frame or are the same distance from the back of the cab, the installer will need to make sure the bed holes line up properly with the center of each mounting post hole.

The basic steps in this section are as follows:

- Layout the bed holes
- Drill the first pilot hole in the bed
- Check centering using the tape method
- Adjust the bed hole layout if necessary
- Drill the second pilot hole and check centering to ensure bed hole locations are square to the frame; adjust as needed
- Drill remaining pilot holes in the bed; check centering
- Drill truck frame, if necessary

Detailed Installation Instructions

1. Use transparent tape to cover the mounting post hole on the top of each mounting bracket (when the pilot hole is drilled through the bed, the tape will be pierced by the small drill; it should be positioned in the center of the 1" mounting post hole).
2. Align the rear driver side mounting bracket's {A} locator post to the existing obround hole located behind of the shock mount crossmember near the truck bed cross sill (*see below*).
3. Fasten the mounting bracket flush to the side and top of the frame (some mounting brackets may have a slight warp due to the metal characteristics during the welding process) by using either a clamp or by using the bracket's corresponding fasteners. Do not overtighten—you will be removing the brackets in later steps.

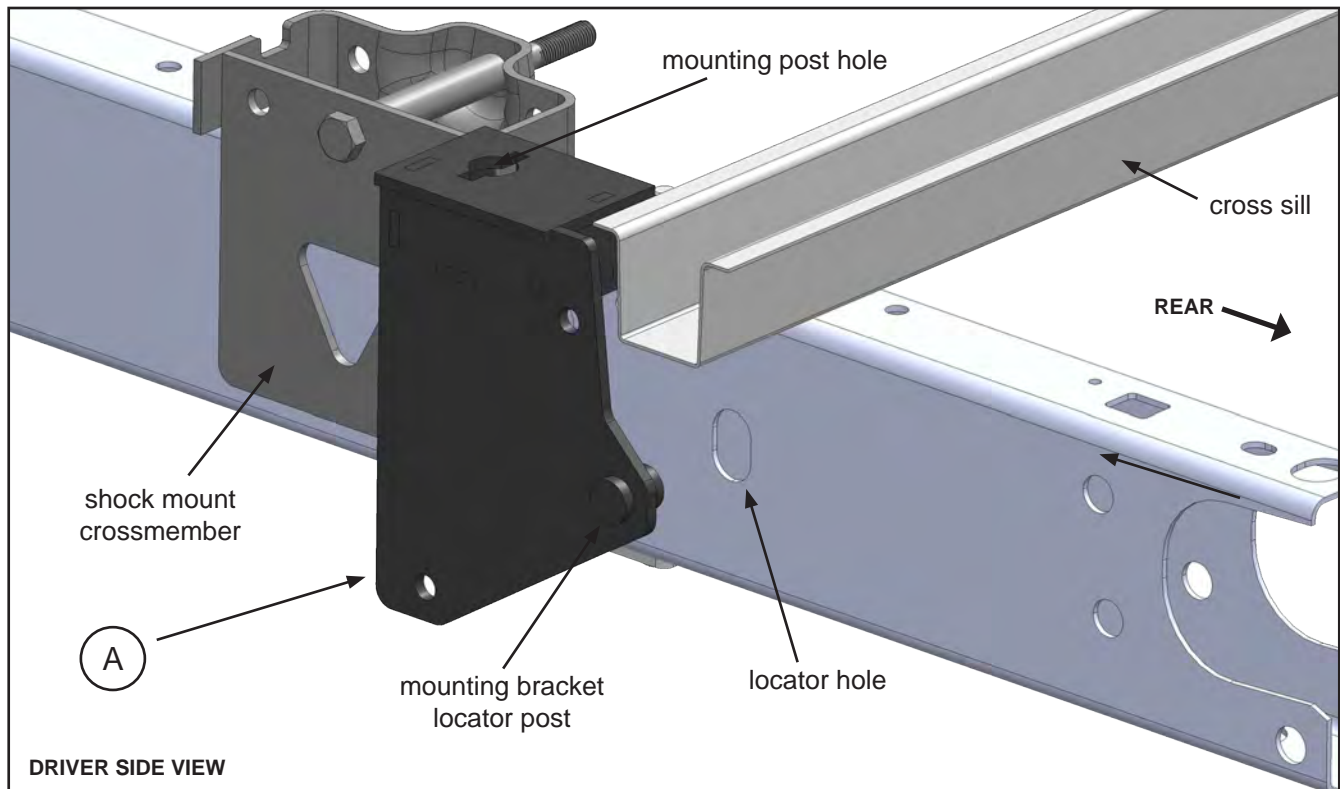

INSTALLATION

4. Drill the first 1/16" pilot hole through the truck bed over the rear hole on the driver side where you made the mark during the "Marking Bed for Drilling." The bit should come down through the 1" mounting post hole, piercing the transparent tape, aiding the centering of the bracket front-to-rear and side-to-side.
5. If the pilot hole is off center to the 1" mounting post hole, remember to adjust all the pilot hole locations accordingly.

NOTE: Some truck beds are not installed square on their frame by the manufacturer. To ensure your pilot holes are aligned properly, it is important that you use the measurements provided only as a starting point and make adjustments as needed. Once you have the rear driver side pilot hole centered, you will use this hole as a point of reference for all remaining pilot hole adjustments. If you are using the Template Method, simply use the properly drilled hole as a pivot point to square the remaining holes to the frame. If you are using the Layout Method, you may accomplish the same thing by using a framing square and straight edge.

6. Repeat steps 2-5 for the rear passenger side mounting bracket {E}, checking carefully for proper centering.
7. The front mounting brackets {B} and {D} (and backup plates {C}) are positioned above the vehicle's jounce bumper on the frame as illustrated below. Repeat steps 3-5 for both front mounting brackets, making sure both brackets sit flush on top of the frame.

NOTE: Final bracket placement is dependent on the fixed position of the rear brackets. The front mounting brackets can be moved forward and back to achieve the "B" measurement indicated on "Truck Bed Dimension Table."

WARNING: Before proceeding to "Part 2, 'Drilling the Bed...'" you must verify that each pilot hole is centered over the 1" mounting post hole on each bracket before the 1-3/4" mounting post holes are drilled through the bed.

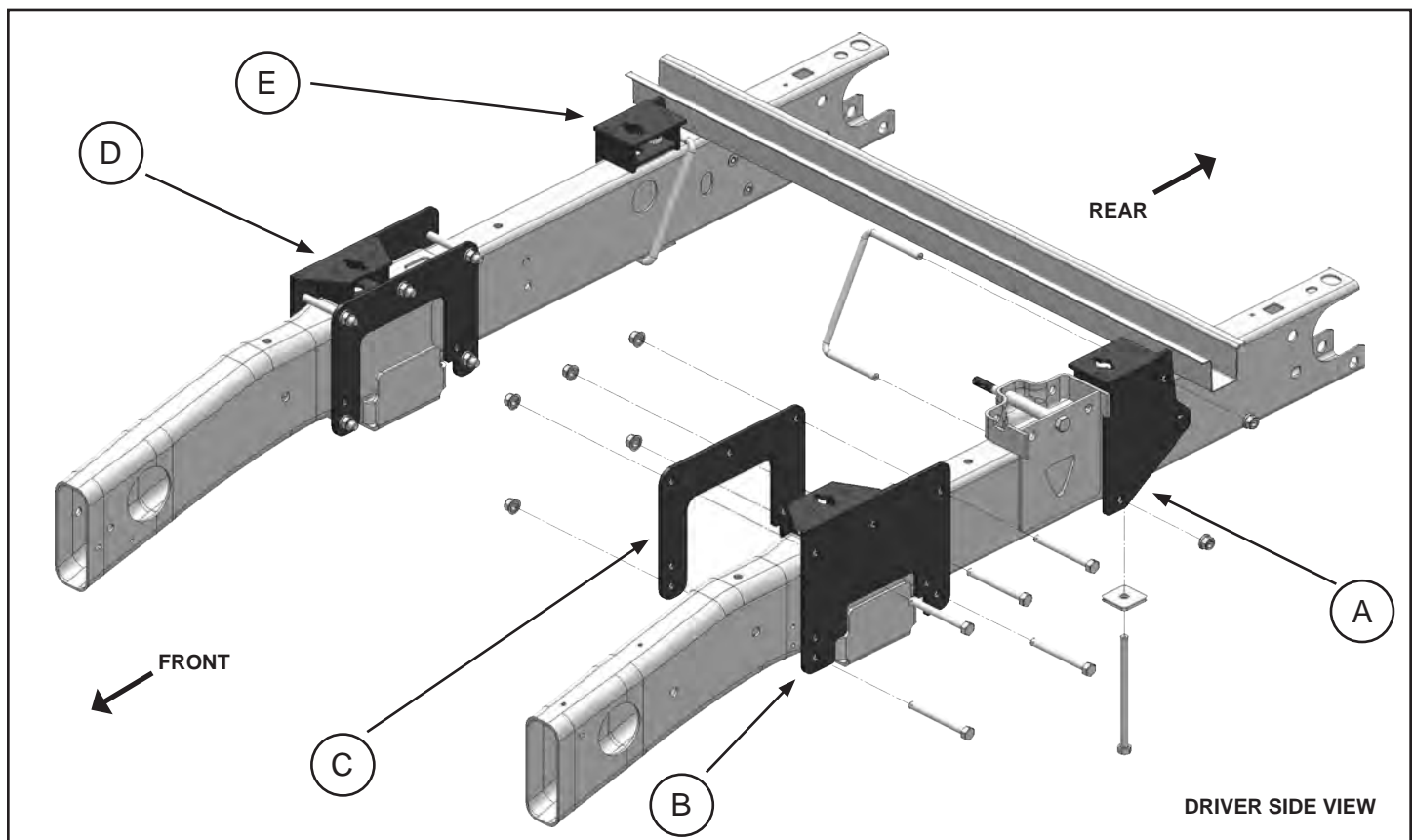

PART 2: DRILLING THE BED & BRACKET INSTALLATION

1. After removing the mounting brackets, use a 1-3/4" hole saw centered over the 1/16" pilot hole and cut the bed for the mounting posts.
2. De-bur inside the holes and use a paint stick to touch up the edges.

REAR MOUNTING BRACKET INSTALLATION

1. Reinstall the rear mounting brackets to the frame.
2. Place the rear mounting bracket flush to the side of the frame and insert the U-bolt and hand tighten nuts.
3. Put the 2" backup plates {S} on the 1/2" x 7-1/2" bolts {T} (*right*).
4. Insert the bolts and plates up through through the frame and hand tighten into the welded nut on the inside of the bracket (*below*).

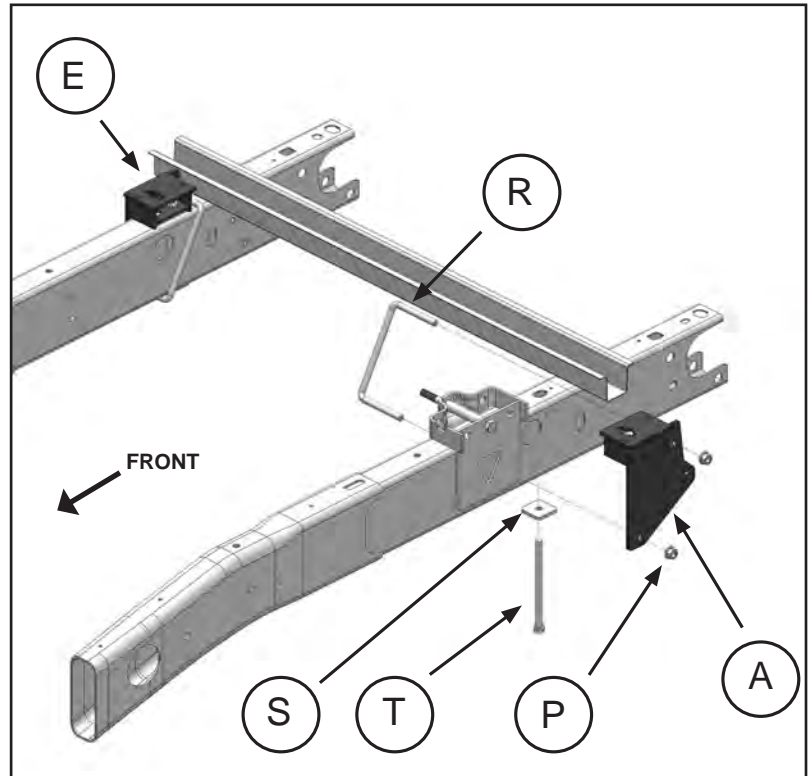
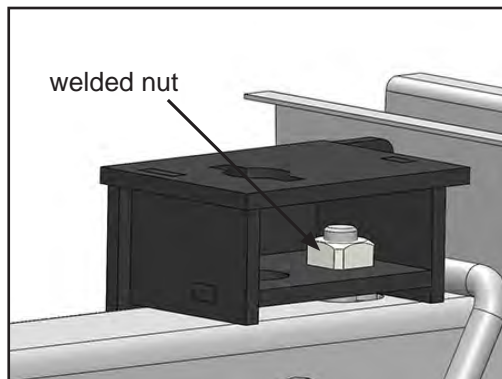

FRONT MOUNTING BRACKET INSTALLATION

1. Reinstall the front mounting brackets {B} and {D}, and backup plates {C} as indicated, using the hardware provided (*right*). Loosely tighten the assembly to the frame as you may need to adjust the assembly in later steps.

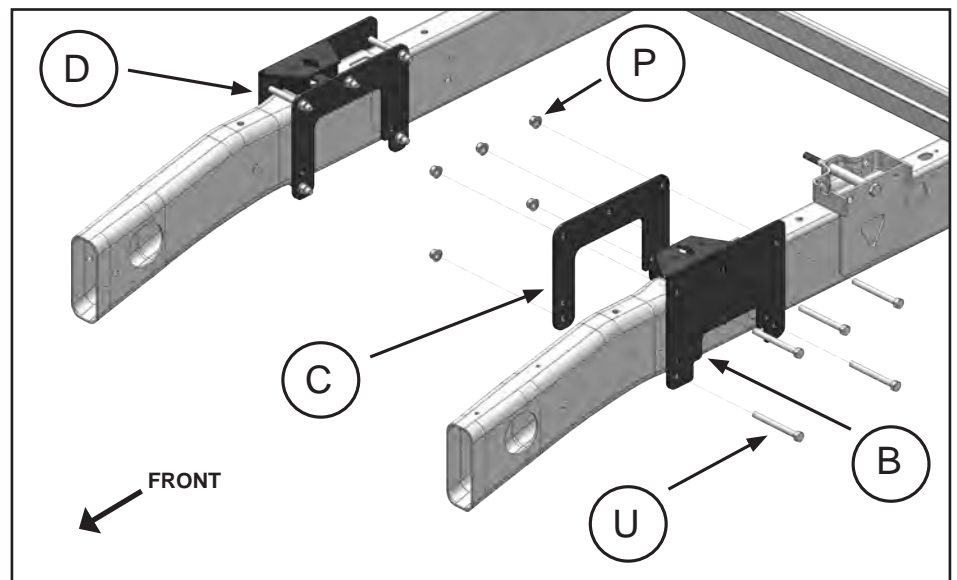

PART 2: DRILLING THE BED & BRACKET INSTALLATION *(CONT.)*

3. Install the mounting posts through the bed into the mounting bracket post holders. Rotate the posts a quarter turn (see the illustration to the right). Four posts are required for installation.

NOTE: Vehicles using plastic bed liners may require taller mounting posts (part# 330705) to seat properly into the post holders.

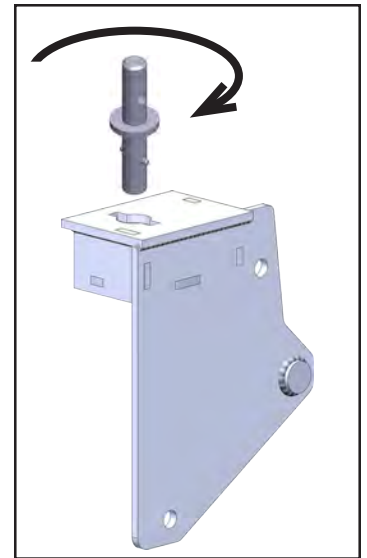

PART 3: HITCH ALIGNMENT

1. Remove the SuperGlide hitch from the shipping carton.
2. Secure the base rail extensions to the base rails, leaving the base rail extensions loose to allow lateral movement as you place the rail assembly over the mounting posts (right).

NOTE: The base rail extensions should be installed with the obround hole (found on the bottom plate of the base rail extension) facing down toward the truck bed, and the round hole facing up.

3. Center the base rails between the mounting posts. Finger tighten the base rail mounting bolts.
4. Set the SuperGlide hitch on the base rails and align the hitch assembly with the mounting holes.
5. Install the hitch pins from the inside. Then install the pin clips, to secure the hitch assembly to the base rails. Use a drift pin to aid your hole alignment.

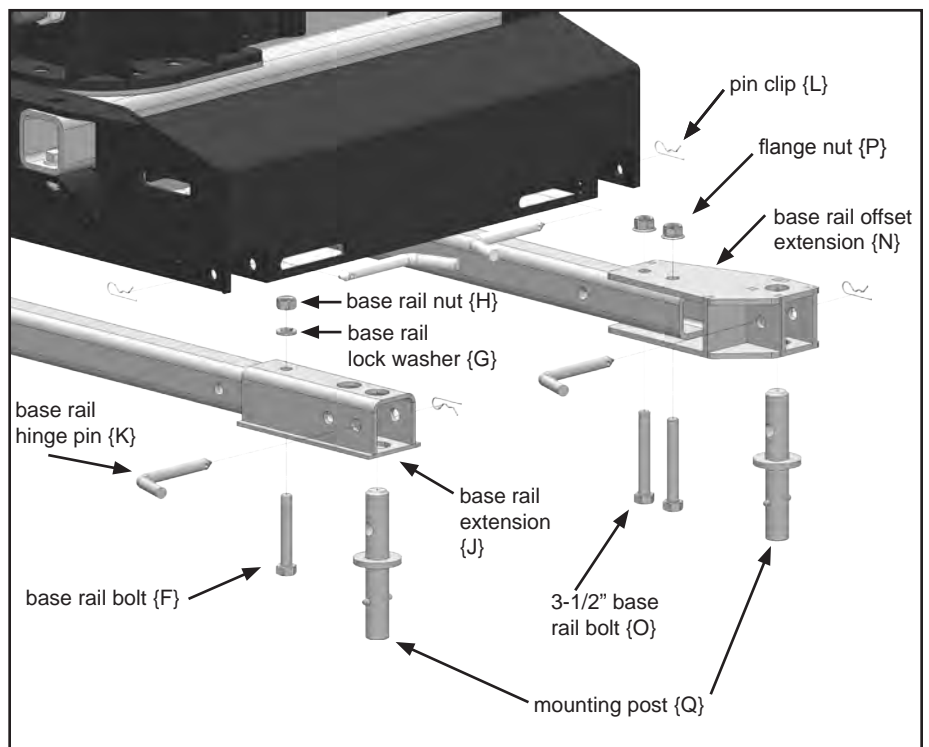

PART 4: FINAL INSTALLATION PROCEDURES

1. Tighten all bolts, including base rail bolts, according to the Torque Table to the right.

NOTE: When tightening the mounting brackets, torque the bolts only until the plates begin to "bend."

2. Remove the hitch and base rail assembly and verify that the mounting posts can be inserted and turned freely without binding. You may need to loosen the bolts on the mounting brackets below if binding occurs. Adjust as needed and retighten the bolts.
3. Reinstall the mounting posts, base rails and the SuperGlide hitch assembly until the assembly can be removed freely without binding.

TORQUE TABLE

3/8" bolt	— 30 ft. lbs.
1/2" bolt	— 75 ft. lbs.
5/8" bolt	— 150 ft. lbs.
3/4" bolt	— 260 ft. lbs.



MANUFACTURED BY:
PULLIAM ENTERPRISES, INC.
13790 East Jefferson Blvd.
Mishawaka, IN 46545
(574) 259-1520 • (800) 443-2307
info@pullrite.com • www.pullrite.com