

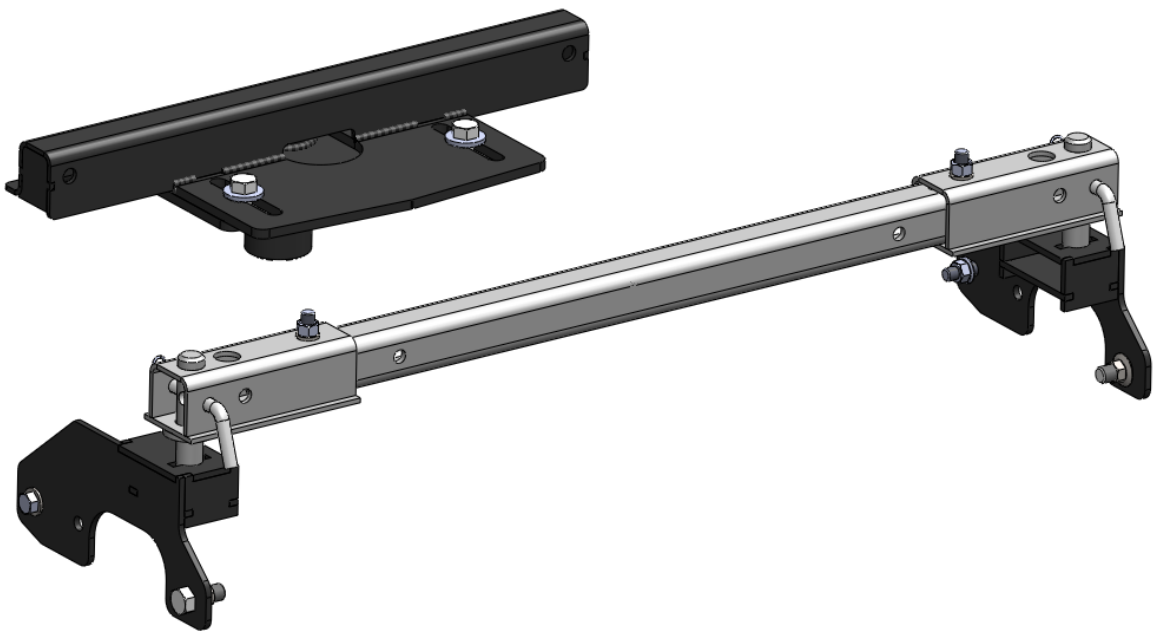

CHEVY

4100/4400 SUPERRAIL MOUNTING KIT
WITH ADAPTER FOR B&W GOOSENECK

PART #4434



Installation Instructions

SPECIFICATIONS

- Fits 1999 - 2010 Chevy 2500 & 3500 Short Bed
 - Mounts to B&W gooseneck part #1067
 - Hitch (kingpin) is centered over axle

HARDWARE PARTS IDENTIFICATION

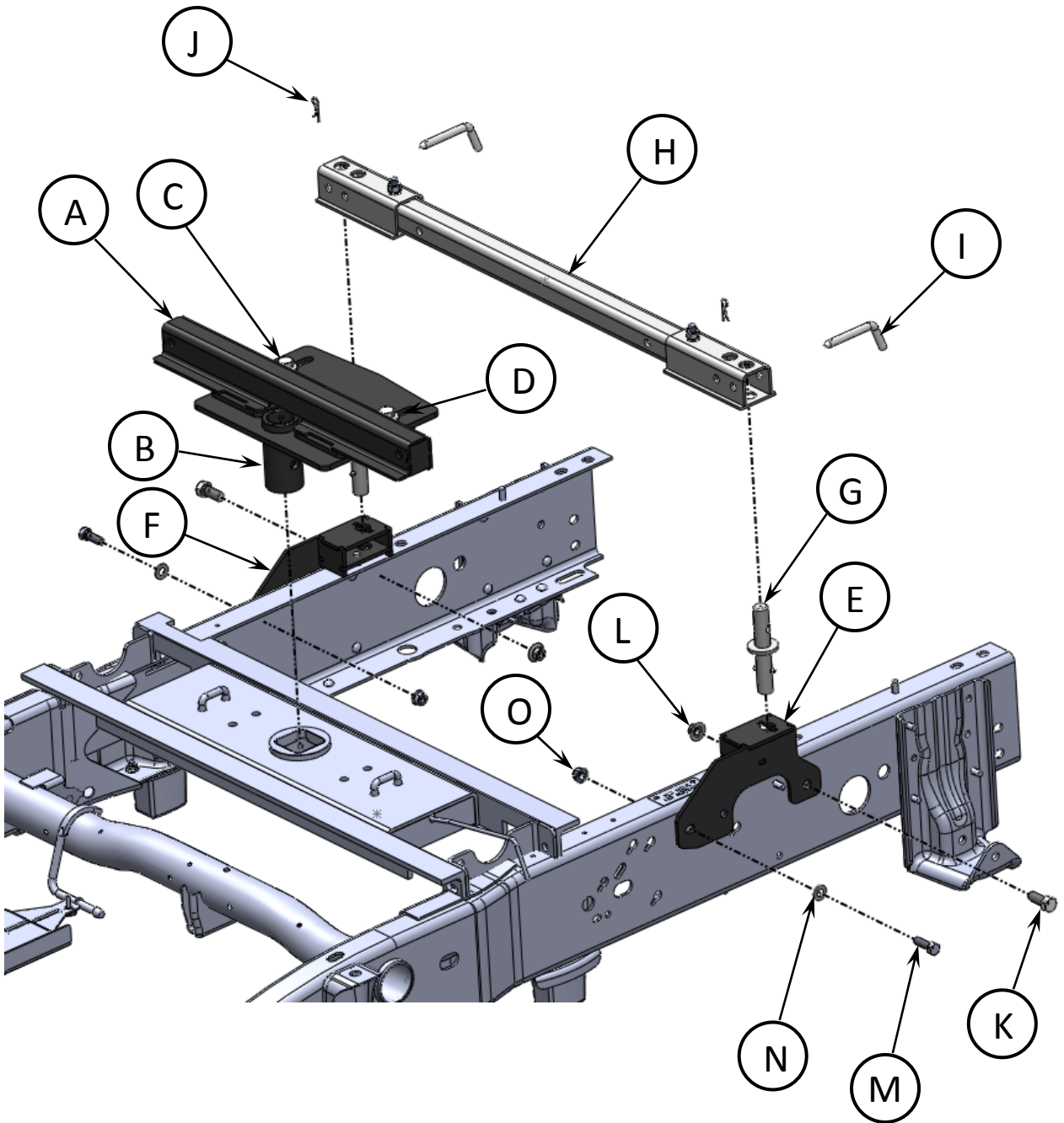

ITEM	P/N	DESCRIPTION	QTY
A	443102	FRONT BASE RAIL ADAPTER ASSEMBLY	1
B	443103	B&W GOOSENECK POST ASSEMBLY	1
C	98010218	5/8"-18 X 1 HEX BOLT	2
D	98200171	5/8" CONICAL TOOTH WASHER	2
E	331503	DRIVER SIDE POST MOUNTING BRACKET ASS'Y	1
F	331504	PASSENGER SIDE POST MOUNTING BRACKET ASS'Y	1
G	330701	MOUNTING POST ASS'Y	2
H	330704	BASE RAIL ASS'Y WITH HARDWARE	1
I	8060001	1/2" PULL PIN	2
J	98410127	SPRING CLIP	2
K	98010231	5/8" BOLT	2
L	98150200	5/8" FLANGE NUT	2
M	98010167	1/2" BOLT	2
N	98250145	1/2" FLAT WASHER	2
O	98150201	1/2" FLANGE NUT	2

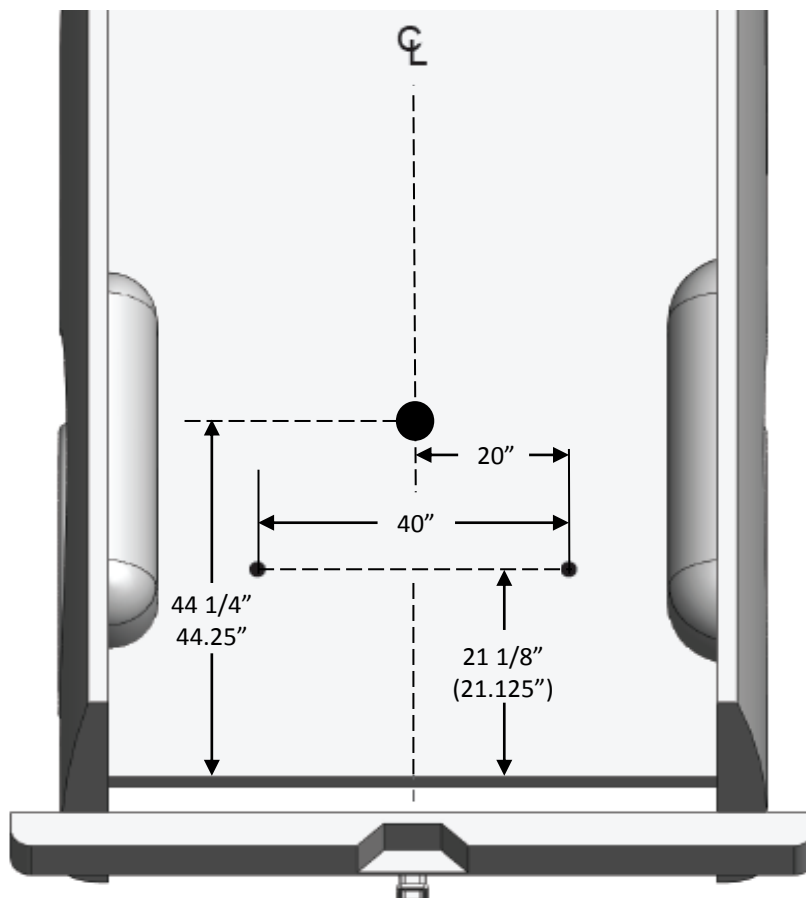

SAFETY CHAIN
U-BOLTS IN
CORRUGATION VALLEY

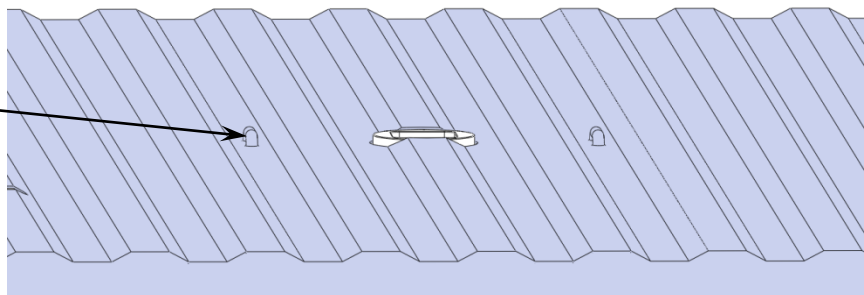

LAYOUT METHOD

1. Verify B&W install distance from rear edge of bed. This dimension to the center of the gooseneck hole should measure 44.25" but **MUST** measure between **42.5 and 45.5"** since the adapter is adjustable. Do not attempt this installation if the gooseneck is installed outside of the specified range.
2. The gooseneck safety chain u-bolts must be installed in the bed corrugation valley; if they are located at a corrugation peak and can not be moved to a valley location, do not attempt the installation.
3. Measure the distance between the wheel wells and mark the bed center line.
4. Measure forward from the rear edge of the bed 21 1/8" (21.125") and mark a line that will position the mounting posts.
5. On the mounting post line, measure 20" outward from the center line to mark the location for each mounting post hole to be drilled.

TEMPLATE METHOD (Part #33150000)

6. Lay the template in the truck bed, centering it from side to side, and parallel to the end of the truck bed. Position it 20 1/8" (20.125") from end of the truck bed.
7. Mark the rear 2 holes while making sure the template does not move.
NOTE: The front 2 holes will not be used.

NOTE: The template should be oriented as shown in the drawing below. Notice that the spacing of the forward and rearward facing holes may be different and can be used to determine the correct orientation of the template. The template has a tendency to move when placed on the slick paint of new truck beds. It may be helpful to plate a small piece of non-skid matting, such as "Scoot-Gard" or simply use duct tape on each corner to help keep the template from moving.

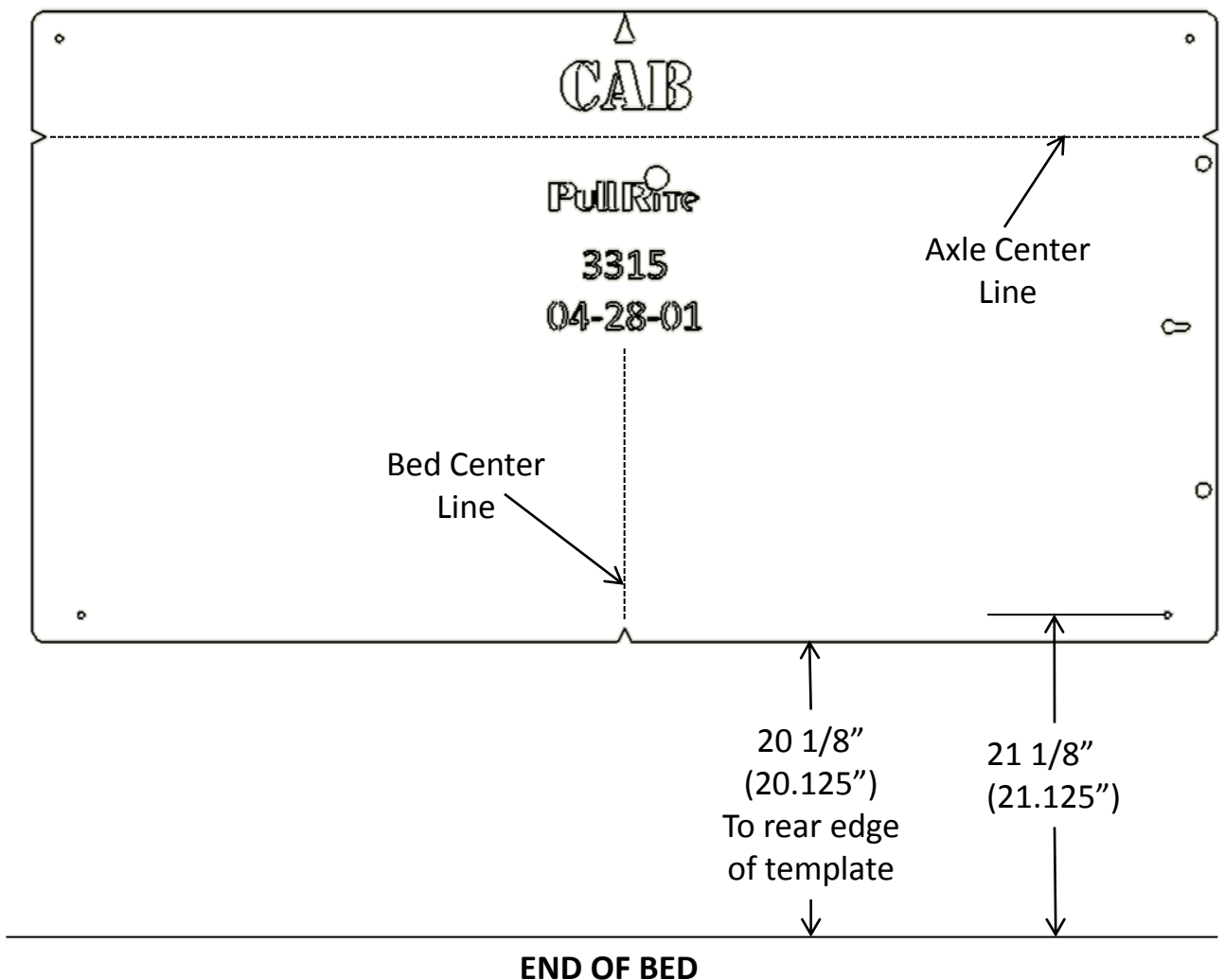

INSTALLATION

MOUNTING POST BRACKET PLACEMENT & BED HOLE LOCATIONS

Since most truck beds are not installed square to the frame or are not the same distance from the back of the cab, the installer will need to make sure the bed holes line up properly with the center of each mounting post hole.

8. Use transparent tape to cover the mounting post hole on the top of each mounting bracket.

WARNING: Prior to drilling any holes, verify that there aren't any fuel lines, brake lines or other obstructions that may be damaged when drilling through the bed or frame.

9. Drill the first 1/16" pilot hole through the truck bed at the mark on the drivers side.
10. Align the drivers side bracket with the frame as shown below. There should be a 1/4" hole in the truck frame that will align with the front most bracket hole. Center these two holes and use a c-clamp to hold the bracket in place. Run the drill bit back through the pilot hole to pierce the tape covering the mounting post hole.

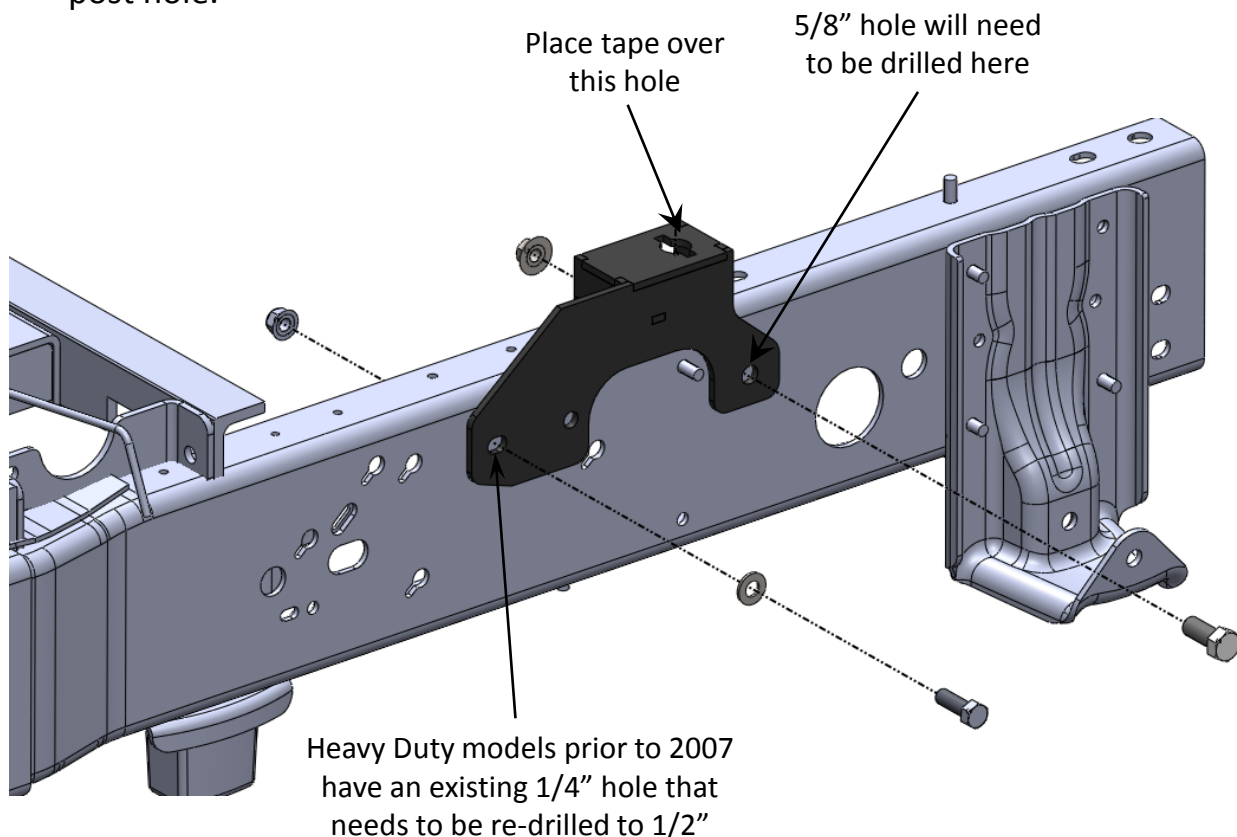

11. Remove the drivers side mounting post bracket from the frame and verify that the drill pierced the tape in the center of the 1" mounting post hole. If the pilot hole is off center, the pilot hole position will need to be adjusted and tape re-pierced. Remember that the passenger side will also have to be adjusted accordingly. Mark the holes that will need to be drilled through the frame using the frame bracket as a template.
12. Once the driver side 1/16" hole is centered in the mounting post hole follow the previous steps to center the hole in the passenger side mounting post bracket.

DRILLING THE BED AND INSTALLING BRACKETS

13. After both pilot holes are centered over the mounting post bracket holes, remove both brackets and use a 2" hole saw centered on the pilot holes to drill through the bed.
14. Deburr both holes to remove sharp edges. The holes can be touched up with paint to prevent corrosion.
15. Reinstall both frame brackets and drill the frame using the bracket as a template. One 1/2" and one 5/8" hole will need to be drilled per side. (See previous page)
16. Install hardware as shown on the parts identification page and torque the 1/2" bolts to 75 ft. lbs. and 5/8" bolts to 150 ft. lbs.
17. Install the mounting posts through the bed into the mounting post brackets. Rotate the posts a quarter turn to position properly (see illustration). Two posts are required for this installation.

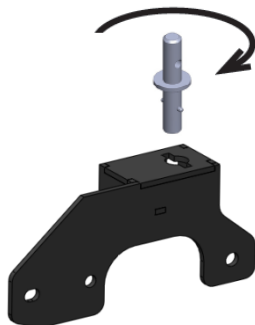

GOOSENECK ADAPTER INSTALLATION AND ADJUSTMENT

18. Install the B&W gooseneck post assembly in the gooseneck as shown in the photo with the bolt holes oriented towards the rear of the vehicle.

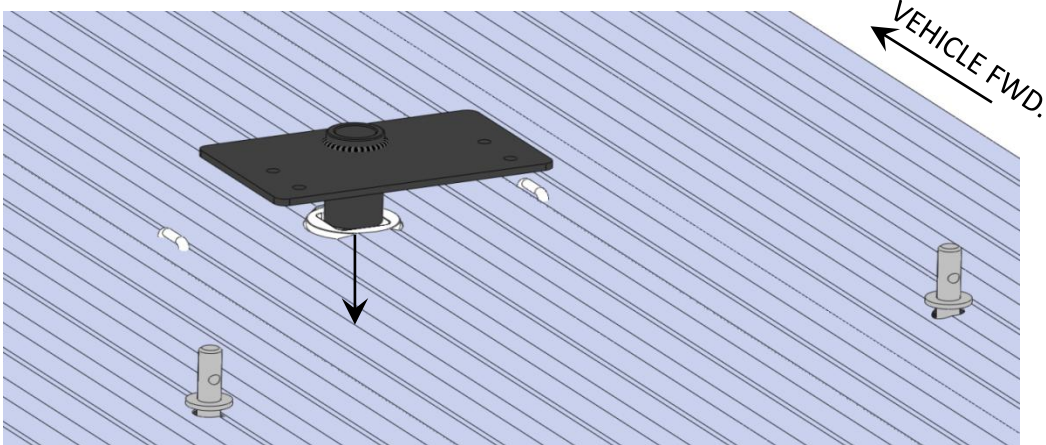

19. Latch the gooseneck pin through the B&W gooseneck post assembly and verify that the pin engages fully and passes completely through the post as shown in the photo below.

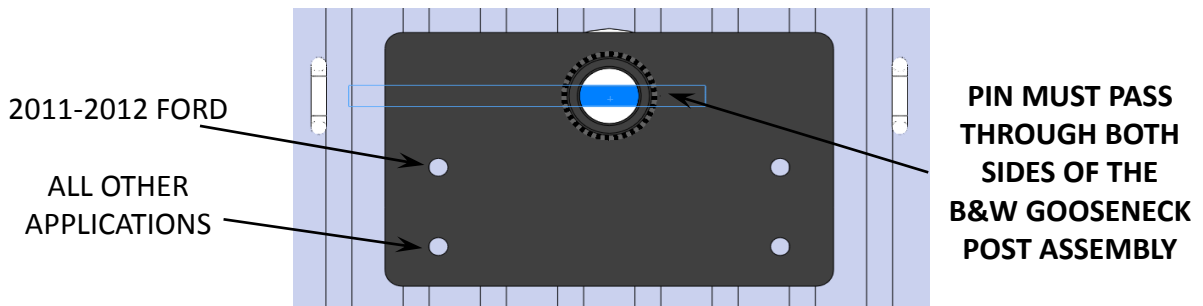

20. Set the front base rail adapter assembly on top of the post adapter plate with the formed rail oriented towards the front of the vehicle.
21. Install the 5/8" hardware as shown. There are two sets of holes in the B&W gooseneck post assembly. If the installation position exposes the front holes (vehicle forward) use these holes; otherwise use the rear two holes. The front two holes are designed for 2011-2012 Ford applications, but may be usable on other fits. Use the provided conical serrated washers between the bolt head and slot in the front base rail adapter assembly. The serrated washers must be oriented so the serrations are facing downward. Leave the bolts loose to allow adjustment of the front base rail adapter assembly when the hitch is installed.

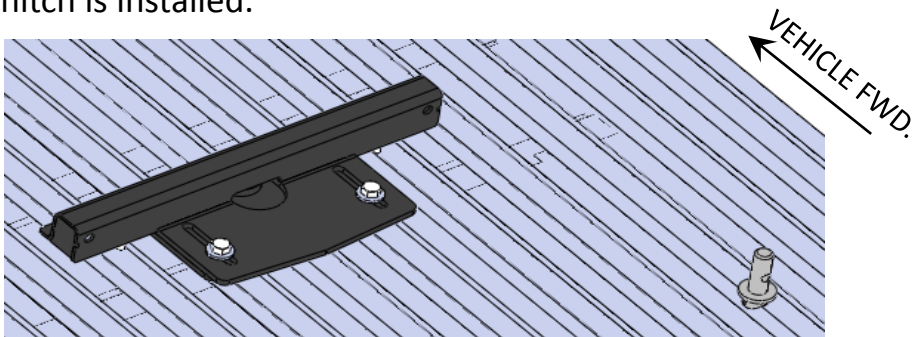

22. Install the rear Base Rail on the mounting posts and install the hitch pins as shown.

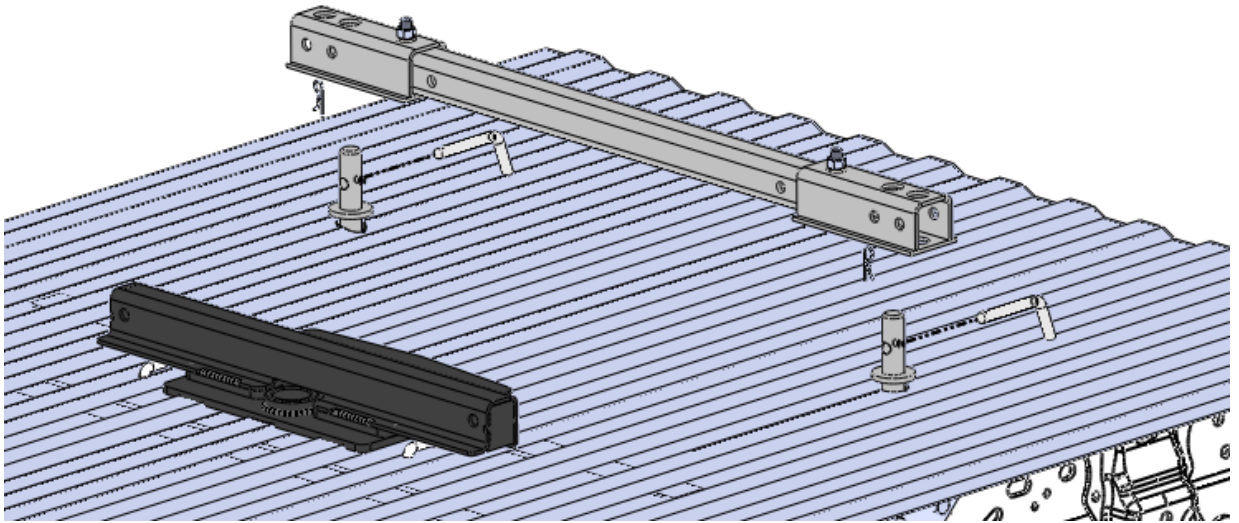

23. Install the Super Glide hitch on the rear Base Rail and adjust the gooseneck adapter position so that it sits in the forward rail opening in the hitch.
24. Install the four 1/2" hitch pins as shown to attach the hitch to the Base Rail and adapter. One pin and clip is installed per corner of the hitch.

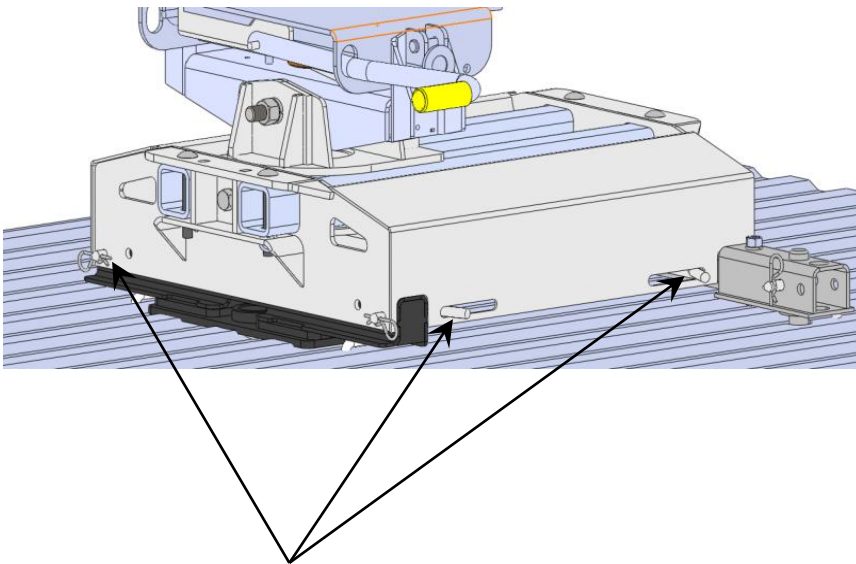

**INSTALL HITCH PINS
AND CLIPS 4 PLACES**

25. Slide the hitch head towards the rear of the vehicle and torque the two 5/8" bolts in the gooseneck adapter to 110 ft. lbs.
26. Torque the two 1/2" rear Base Rail bolts to 75 ft. lbs.

TORQUE TWO 5/8" BOLTS

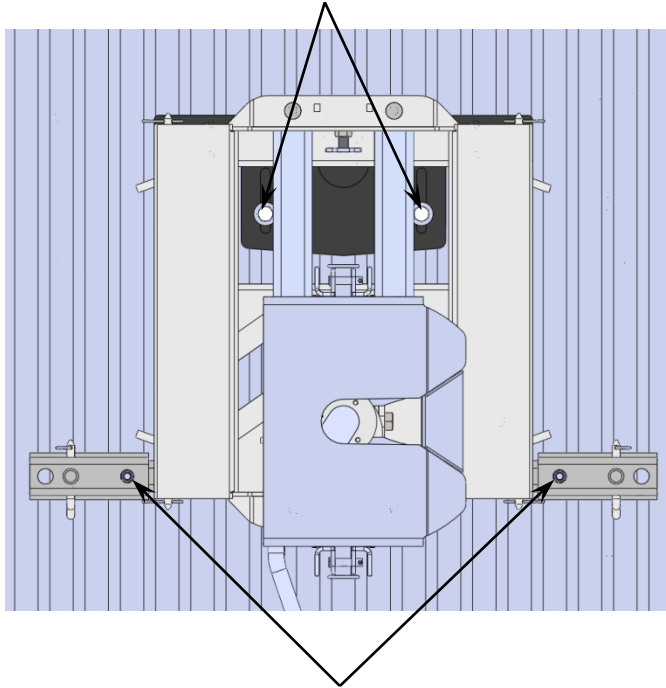

TORQUE TWO 1/2" BOLTS

27. Verify that all gooseneck mounting hardware is torqued per the manufacturers recommendation prior to towing.
28. Verify that the Super Glide threaded stop assembly is adjusted properly with the hitch in the straight towing position. Refer to the Super Glide owners manual for this procedure.
29. The adapter hardware should be checked and re-torqued periodically to prevent unwanted hitch movement and fastener damage.
30. If the two 5/8" threaded holes ever become damaged or cross threaded it will be necessary to order a replacement B&W post adapter part #443103 and hardware kit part #443104.