

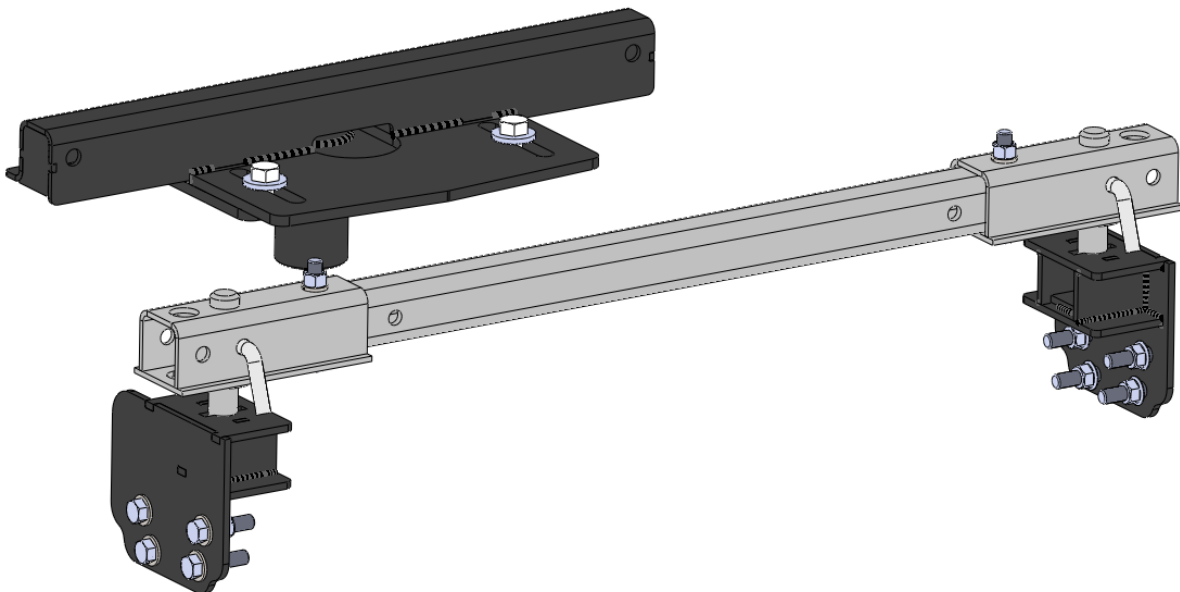

FORD

4100/4400 SUPERRAIL MOUNTING KIT
WITH ADAPTER FOR B&W GOOSENECK

PART #4431



Installation Instructions

SPECIFICATIONS

- Fits 1999 – 2016 Ford F250 & F350 Short Bed
- Mounts to B&W gooseneck part #1108 & 1111
 - Hitch (kingpin) is centered over axle

HARDWARE PARTS IDENTIFICATION

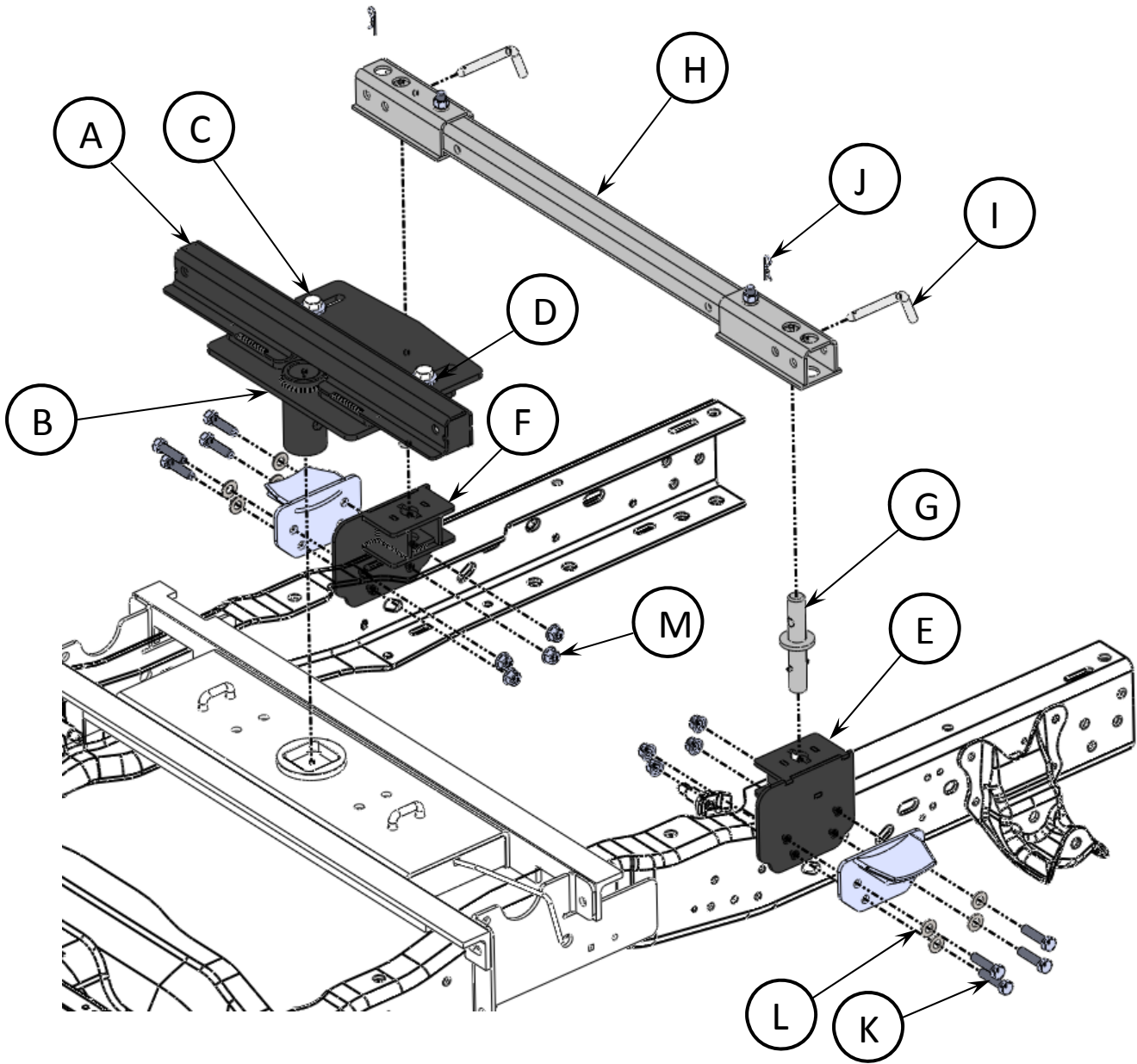

ITEM	P/N	DESCRIPTION	QTY
A	443102	FRONT BASE RAIL ADAPTER ASSEMBLY	1
B	443103	B&W GOOSENECK POST ASSEMBLY	1
C	98010218	5/8"-18 X 1 HEX BOLT	2
D	98200171	5/8" CONICAL TOOTH WASHER	2
E	443106	DRIVER SIDE POST MOUNTING BRACKET ASS'Y	1
F	443107	PASSENGER SIDE POST MOUNTING BRACKET ASS'Y	1
G	330701	MOUNTING POST ASS'Y	2
H	330704	BASE RAIL ASS'Y WITH HARDWARE	1
I	08060001	1/2" PULL PIN	2
J	98410127	SPRING CLIP	2
K	98010175	1/2"-13 X 2 BOLT	8
L	98250145	1/2" FLAT WASHER	8
M	98150201	1/2"-13 SERRATED FLANGE NUT	8

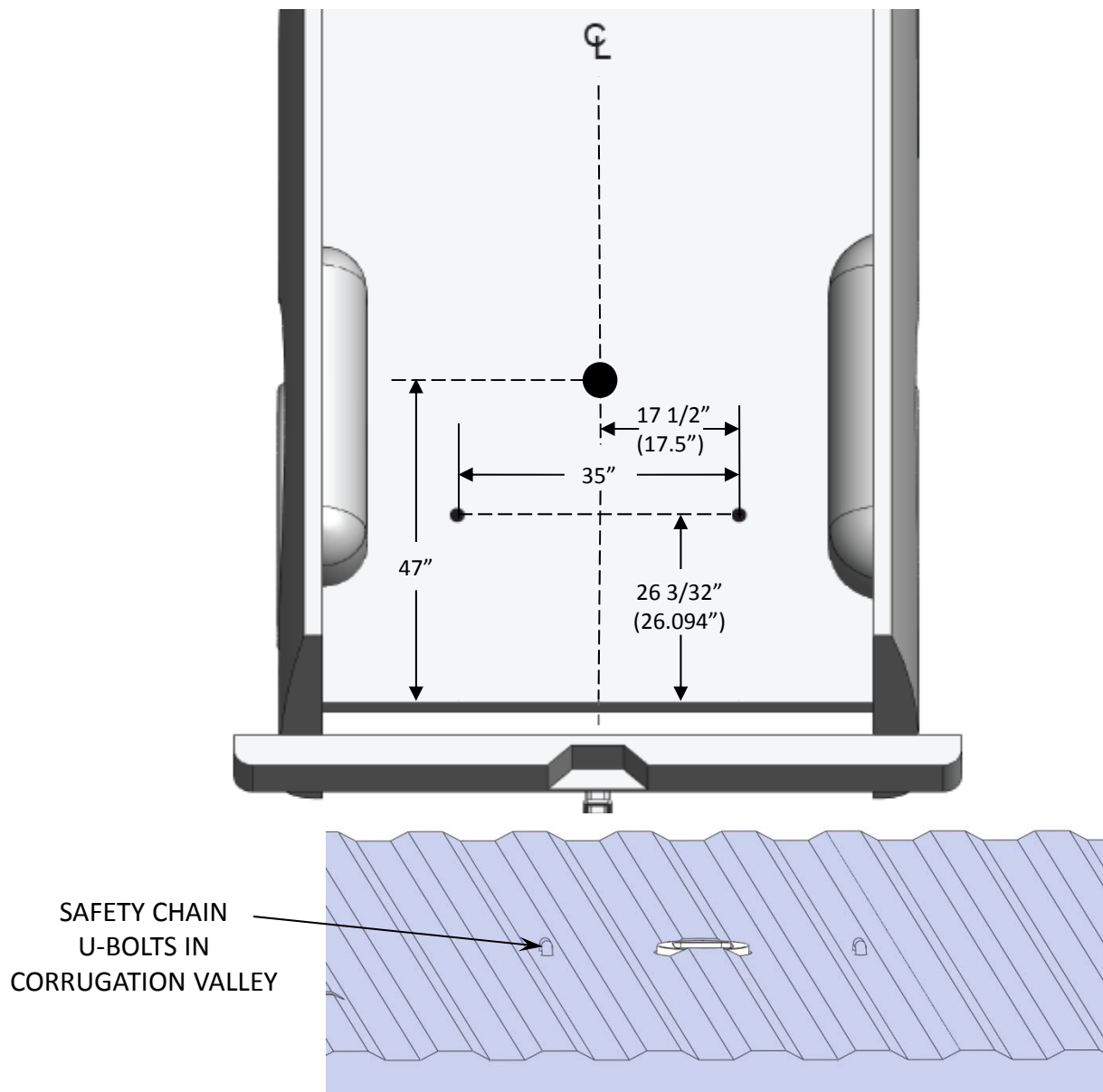

LAYOUT METHOD

1. Verify B&W install distance from rear edge of bed. This dimension to the center of the gooseneck hole should measure 47" but **MUST** measure between **46.0 and 49.5"** since the adapter is adjustable. Do not attempt this installation if the gooseneck is installed outside of the specified range.
2. The gooseneck safety chain u-bolts must be installed in the bed corrugation valley; if they are located at a corrugation peak and can not be moved to a valley location, do not attempt the installation.
3. Measure the distance between the wheel wells and mark the bed center line.
4. Measure forward from the rear edge of the bed 26 3/32" (26.094") and mark a line that will position the mounting posts.
5. On the mounting post line, measure 17.5" outward from the center line to mark the location for each mounting post hole to be drilled.

TEMPLATE METHOD (Part #33130000)

- 6. Lay the template in the truck bed, centering it from side to side, and parallel to the end of the truck bed. Position it 25 3/32" from end of the truck bed
 - 7. Mark the rear 2 holes while making sure the template does not move.
- NOTE: The front 2 holes will not be used.**

NOTE: The template should be oriented as shown in the drawing below. Notice that the spacing of the forward and rearward facing holes may be different and can be used to determine the correct orientation of the template. The template has a tendency to move when placed on the slick paint of new truck beds. It may be helpful to plate a small piece of non-skid matting, such as "Scoot-Gard" or simply use duct tape on each corner to help keep the template from moving.

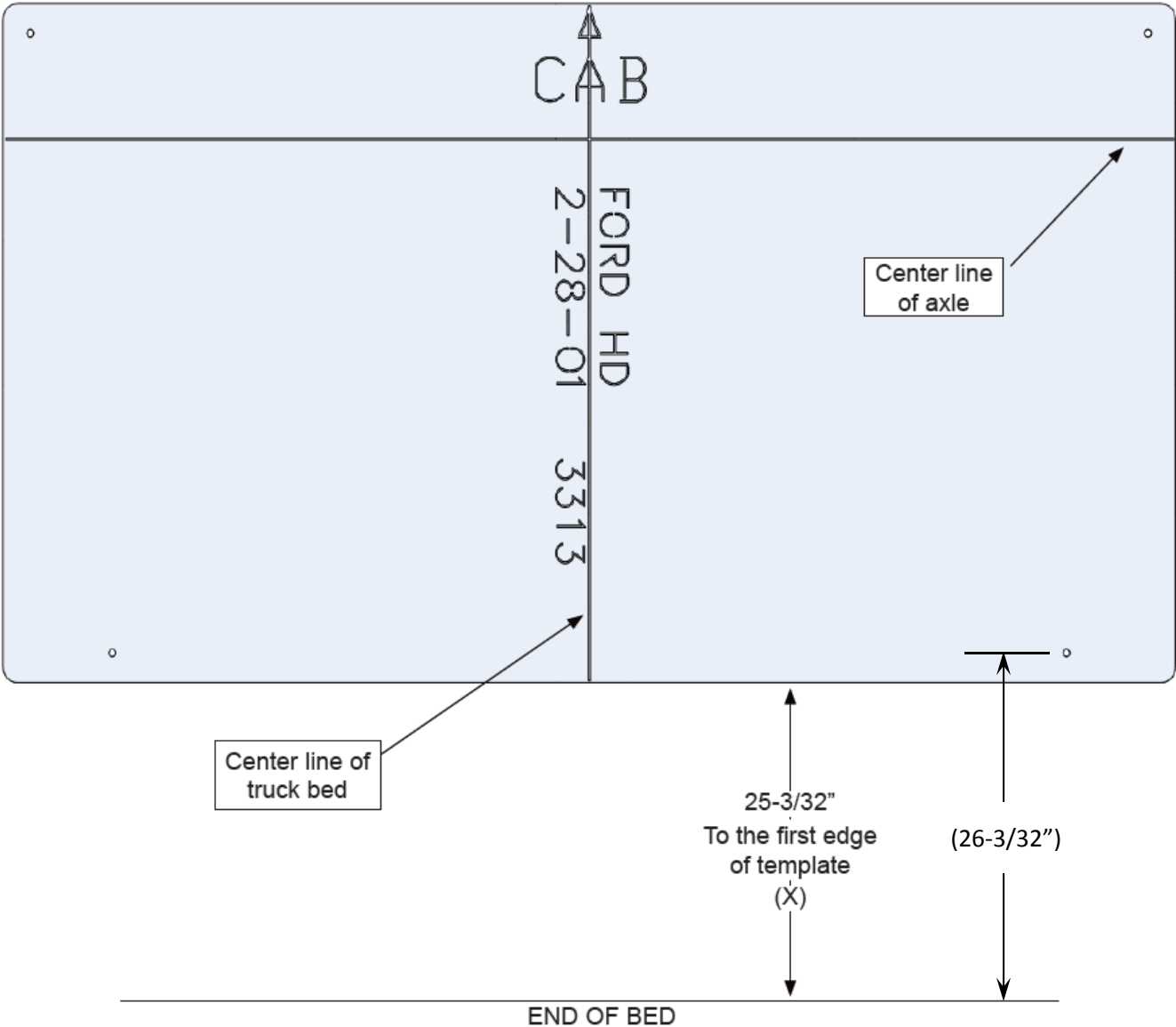

INSTALLATION

MOUNTING POST BRACKET PLACEMENT & BED HOLE LOCATIONS

Since most truck beds are not installed square to the frame or are not the same distance from the back of the cab, the installer will need to make sure the bed holes line up properly with the center of each mounting post hole.

8. Use transparent tape to cover the mounting post hole on the top of each mounting bracket. When the pilot hole is drilled through the bed, the tape will be pierced by the small drill. It should be positioned in the center of the 1" mounting post hole.
9. If the vehicle is equipped with overload brackets, they will need to be temporarily removed to attach the mounting post brackets using the same frame holes. Reuse the overload bracket hardware when attaching the mounting post and overload brackets. The mounting post bracket will be sandwiched between the overload bracket and the frame as shown below.
10. If the vehicle is not equipped with overload brackets, the frame holes on both sides of the frame will have to be drilled to 1/2" or 17/32" diameter so the mounting post brackets can be attached with the supplied 1/2" hardware.

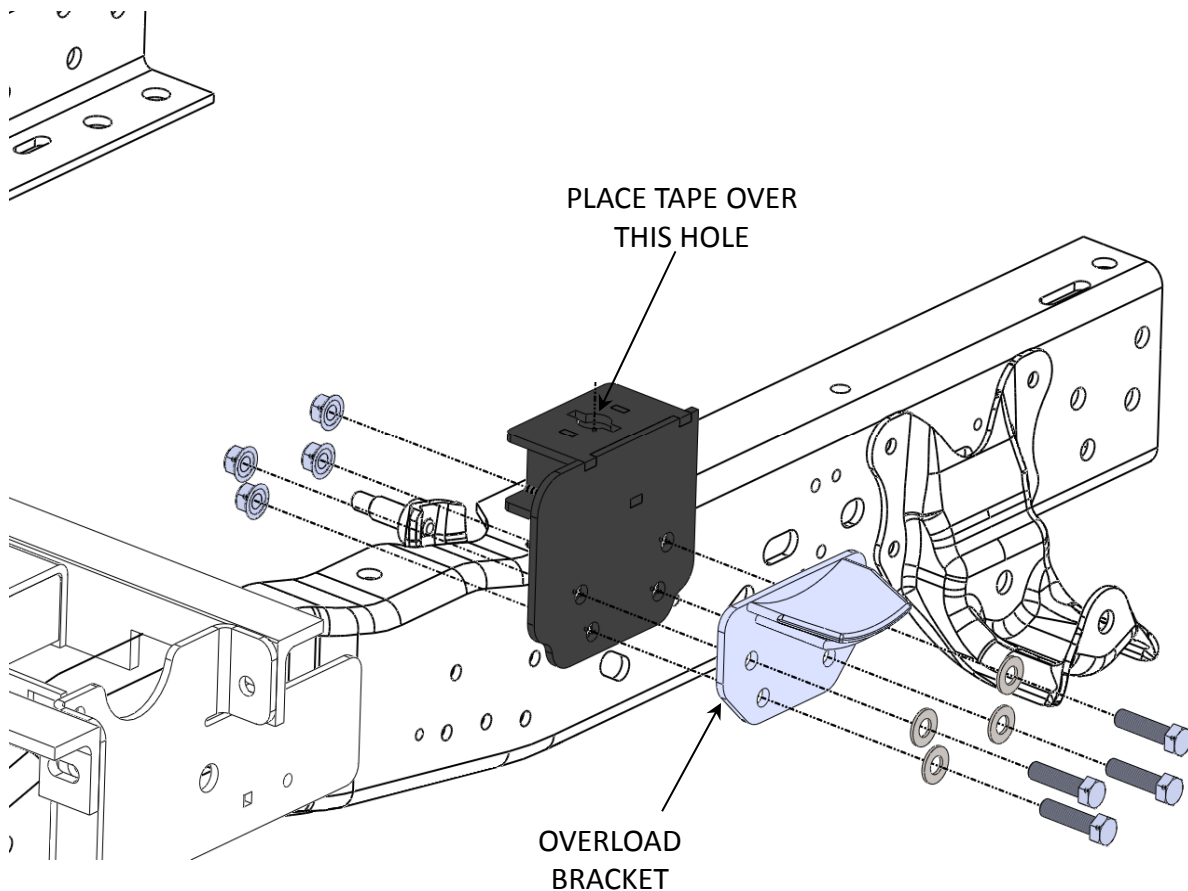

11. Temporarily attach the mounting post brackets to the frame to verify hole drill positions. For alignment purposes, at least two bolts per side must be installed and tightened until the bracket is pulled flat against the frame.

WARNING: Prior to drilling any holes, verify that there aren't any fuel lines, brake lines or other obstructions that may be damaged when drilling through the bed or frame.

12. Drill the first 1/16" pilot hole through the truck bed over the rear hole on the drivers side of the bed. The drill bit should pierce the transparent tape on the mounting post bracket.
13. Remove the drivers side mounting post bracket from the frame and verify that the drill pierced the tape in the center of the 1" mounting post hole. If the pilot hole is off center, the pilot hole position will need to be adjusted and re-drilled. Remember that the passenger side will also have to be adjusted accordingly.
14. Once the driver side 1/16" hole is centered in the mounting post hole follow the previous steps to center the hole in the passenger side mounting post bracket.

DRILLING THE BED AND INSTALLING BRACKETS

15. After both pilot holes are centered over the mounting post bracket holes, remove both brackets and use a 2" hole saw centered on the pilot holes to drill through the bed.
16. Deburr both holes to remove sharp edges. The holes can be touched up with paint to prevent corrosion.
17. Reinstall both mounting post brackets sandwiching them between the frame and overload brackets (if equipped). Install hardware as shown on the parts identification page and torque these eight 1/2" bolts to 75 ft. lbs.
18. Install the mounting posts through the bed into the mounting post brackets. Rotate the posts a quarter turn to position properly (see illustration). Two posts are required for this installation.

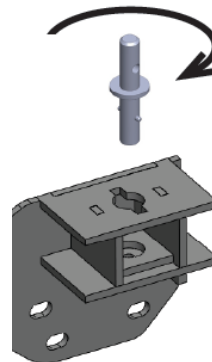

GOOSENECK ADAPTER INSTALLATION AND ADJUSTMENT

19. Install the B&W gooseneck post assembly in the gooseneck as shown in the photo with the bolt holes oriented towards the rear of the vehicle.

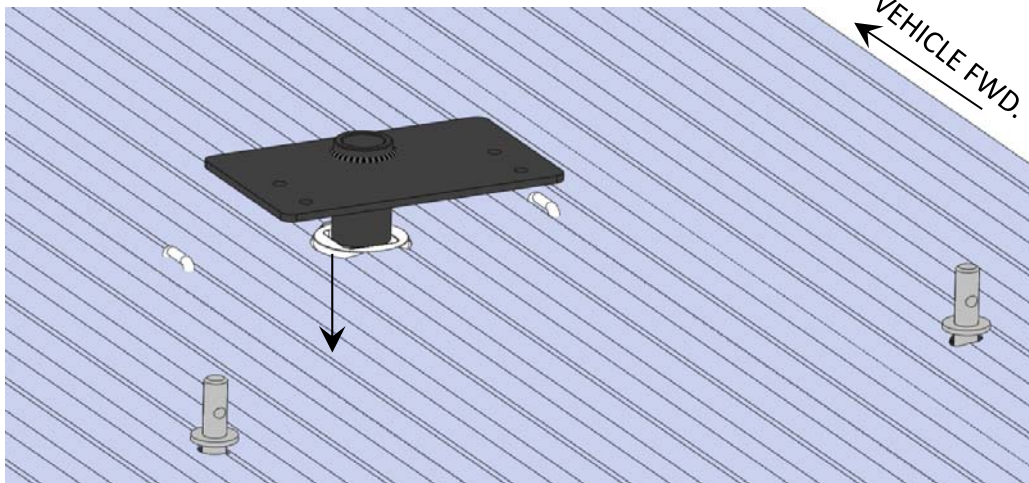

20. Latch the gooseneck pin through the B&W gooseneck post assembly and verify that the pin engages fully and passes completely through the post as shown in the photo below.

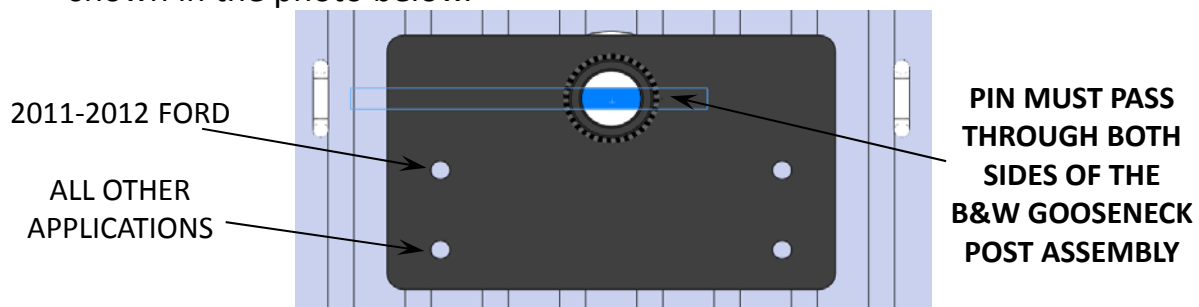

21. Set the front base rail adapter assembly on top of the post adapter plate with the formed rail oriented towards the front of the vehicle.
22. Install the 5/8" hardware as shown. There are two sets of holes in the B&W gooseneck post assembly. If the installation position exposes the front holes (vehicle forward) use these holes; otherwise use the rear two holes. The front two holes are designed for 2011-2012 Ford applications, but may be usable on other fits. Use the provided conical serrated washers between the bolt head and slot in the front base rail adapter assembly. The serrated washers must be oriented so the serrations are facing downward. Leave the bolts loose to allow adjustment of the front base rail adapter assembly when the hitch is installed.

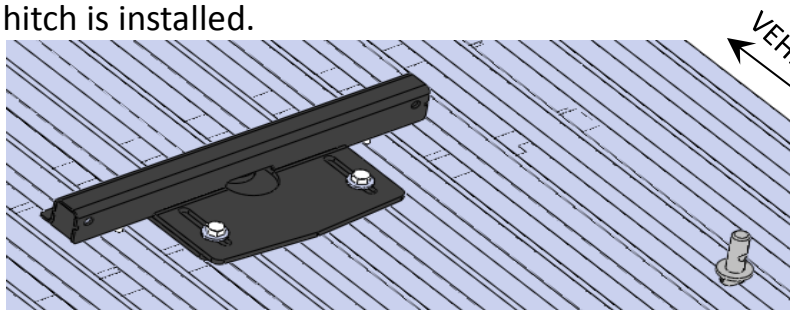

23. Install the rear Base Rail on the mounting posts and install the hitch pins as shown.

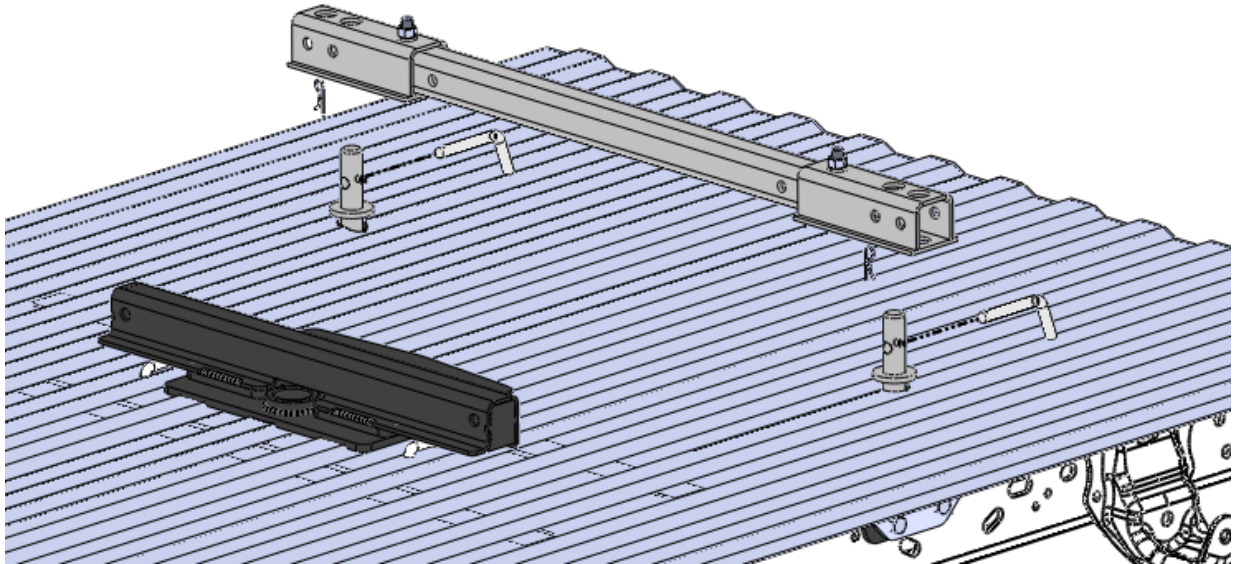

24. Install the Super Glide hitch on the rear Base Rail and adjust the gooseneck adapter position so that it sits in the forward rail opening in the hitch.
25. Install the four 1/2" hitch pins as shown to attach the hitch to the Base Rail and adapter. One pin and clip is installed per corner of the hitch.

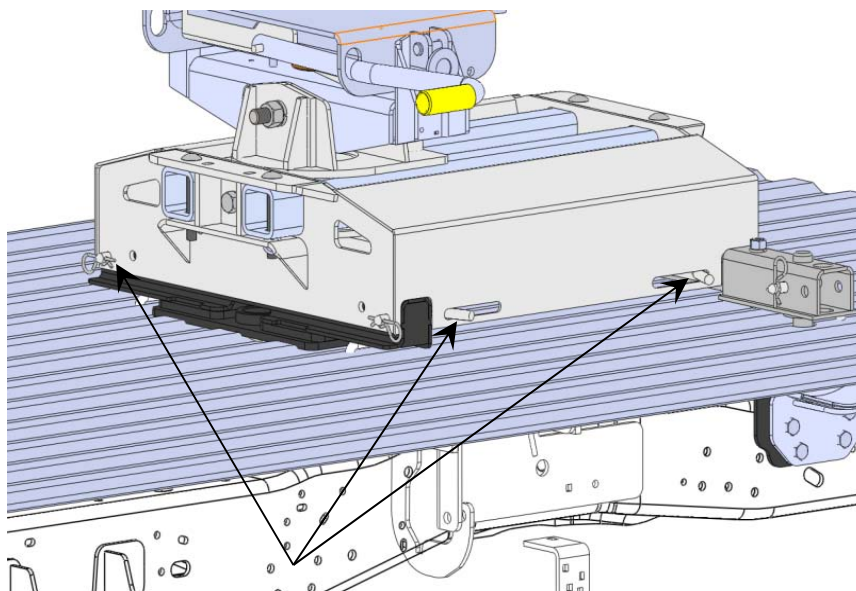

**INSTALL HITCH PINS
AND CLIPS, 4 PLACES**

26. Slide the hitch head towards the rear of the vehicle and torque the two 5/8" bolts in the gooseneck adapter to 110 ft. lbs.
27. Torque the two 1/2" rear Base Rail bolts to 75 ft. lbs.

TORQUE TWO 5/8" BOLTS

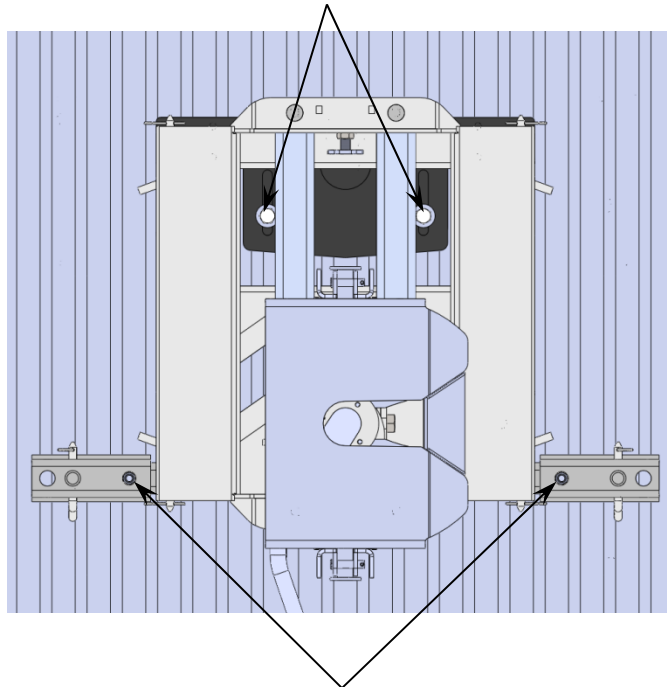

TORQUE TWO 1/2" BOLTS

28. Verify that all gooseneck mounting hardware is torqued per the manufacturers recommendation prior to towing.
29. Verify that the Super Glide threaded stop assembly is adjusted properly with the hitch in the straight towing position. Refer to the Super Glide owners manual for this procedure.
30. The adapter hardware should be checked and re-torqued periodically to prevent unwanted hitch movement and fastener damage.
31. If the two 5/8" threaded holes ever become damaged or cross threaded it will be necessary to order a replacement B&W post adapter part #443103 and hardware kit part #443104.