

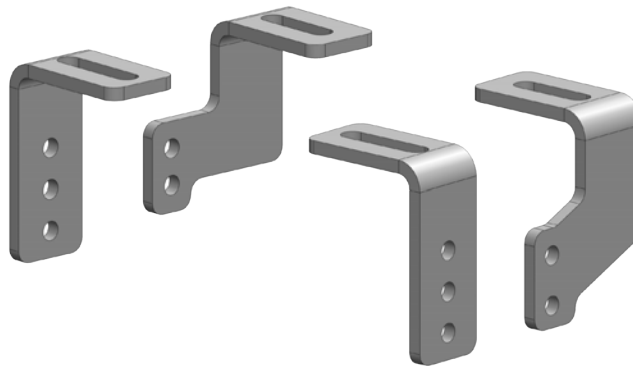

UNIVERSAL

20K Industry Standard Rail Universal Mounting Kit

#2720



Gross Trailer Weight (Maximum).....20,000 lbs.
Vertical Load Weight (Max. Pin Weight).....5,000 lbs.

SYSTEM TOW CAPACITY

Please note, in order to determine the **total tow capacity** of a system, you must consider the weight ratings of each component in that system. This includes, but may not be limited to, the capacity/rating of the **tow vehicle**, the **fifth wheel hitch**, and the hitch's **mounting system**. Actual tow capacity of the system will be equal to the lowest rated component.

Installation Instructions

SPECIFICATIONS

- Fits 2001-2016 Chevy/GMC 2500 & 3500
 - Fits 2007-2017 Chevy/GMC 1500
 - Fits 1999-2016 Ford F250 & F350
- Fits 2003-2012 Dodge 2500 & 3500 (*does not fit 3500 w/ overload springs*)
 - Hitch is located center of the axle
- Universal Mounting Bracket Kit (*Bracket & Hardware*) #2721

TABLE OF CONTENTS

PLATE ASSEMBLY.....	3
MOUNTING HARDWARE PARTS IDENTIFICATION	4
PARTS LIST	5
MARKING THE TRUCK BED FOR DRILLING.....	6
LAYOUT METHOD	6
TEMPLATE METHOD	7
TRUCK PREPARATION.....	8
GENERAL INSTALLATION	8
1999-2007 FORD F250 & F350	10
VEHICLE SPECIFIC INSTRUCTIONS.....	10
2008-2016 FORD F250 & F350	11
VEHICLE SPECIFIC INSTRUCTIONS.....	11
2001-2010 CHEVY/GMC 2500 & 3500	12
VEHICLE SPECIFIC INSTRUCTIONS.....	12
2011-2016 CHEVY/GMC 2500 & 3500	13
VEHICLE SPECIFIC INSTRUCTIONS.....	13
2007-2017 CHEVY/GMC 1500.....	14
VEHICLE SPECIFIC INSTRUCTIONS.....	14
2003-2012 DODGE 2500 & 3500 (WITHOUT OVERLOAD SUPPORTS).....	15
VEHICLE SPECIFIC INSTRUCTIONS.....	15

PLATE ASSEMBLY

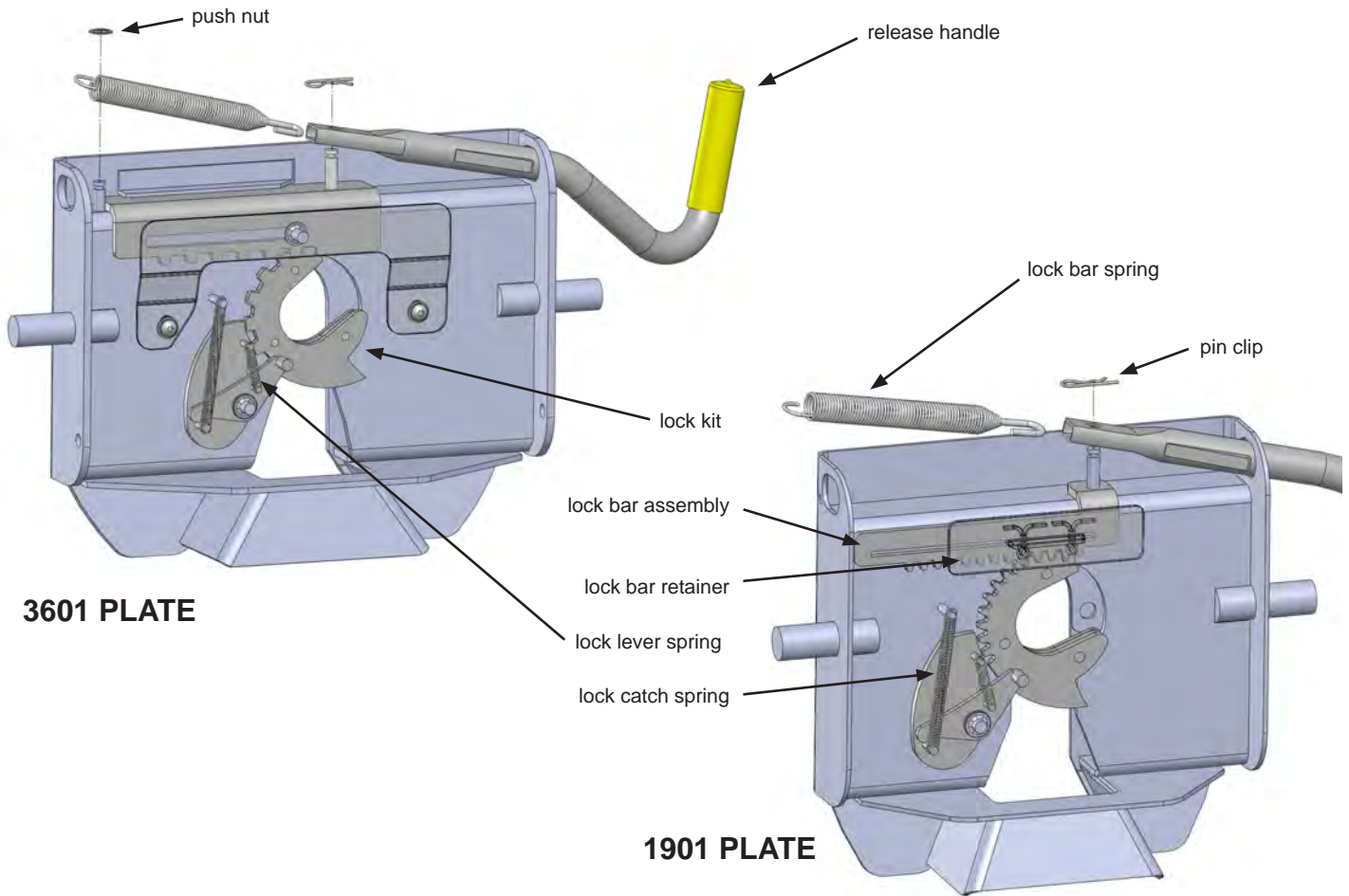

1. Remove the Fifth Wheel Plate from the Rocker Arm and place it upside down on a smooth, clean surface.
2. Insert the Release Handle into the obround hole of the plate as seen above.
3. The Lock Bar Spring must be placed inside the handle prior to placing the handle down over the pin of the Lock Bar Assembly, “catching” the hook inside the handle around the pin.
4. Push the handle and spring assembly down past the groove in the pin of the Lock Bar Assembly, and place one of the Pin Clips in the groove of the pin to fasten.
5. Grip the body of the spring and stretch it far enough over the opposite pin (welded to the plate) and push it down past the groove.
6. Install the Push Nut to secure the Lock Bar Spring onto the welded pin.

NOTE: The 1901 plate for the #1900 Super 5th does not use a push nut to attach the end of the spring, but rather a slot in the side of the fifth wheel plate located above the obround hole. See illustration to the right.

As a PullRite fifth wheel hitch owner, it is important for you to study and manually operate the Fifth Wheel Plate and Release Handle to better understand the locking action. A better working knowledge of the plate will help prevent accidental dropping of your trailer due to incorrect hitching.

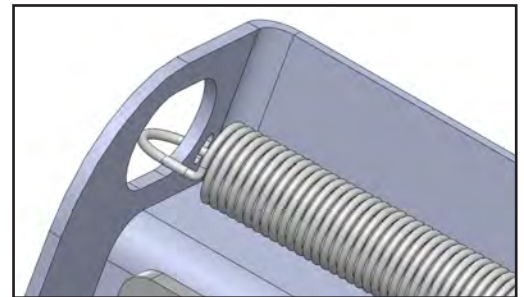

Also, it is imperative that you study and adhere to the Maintenance procedures provided in the Owners Manual. If you did not receive one upon purchase, please contact PullRite or visit us on the web at www.pullrite.com.

MOUNTING HARDWARE PARTS IDENTIFICATION

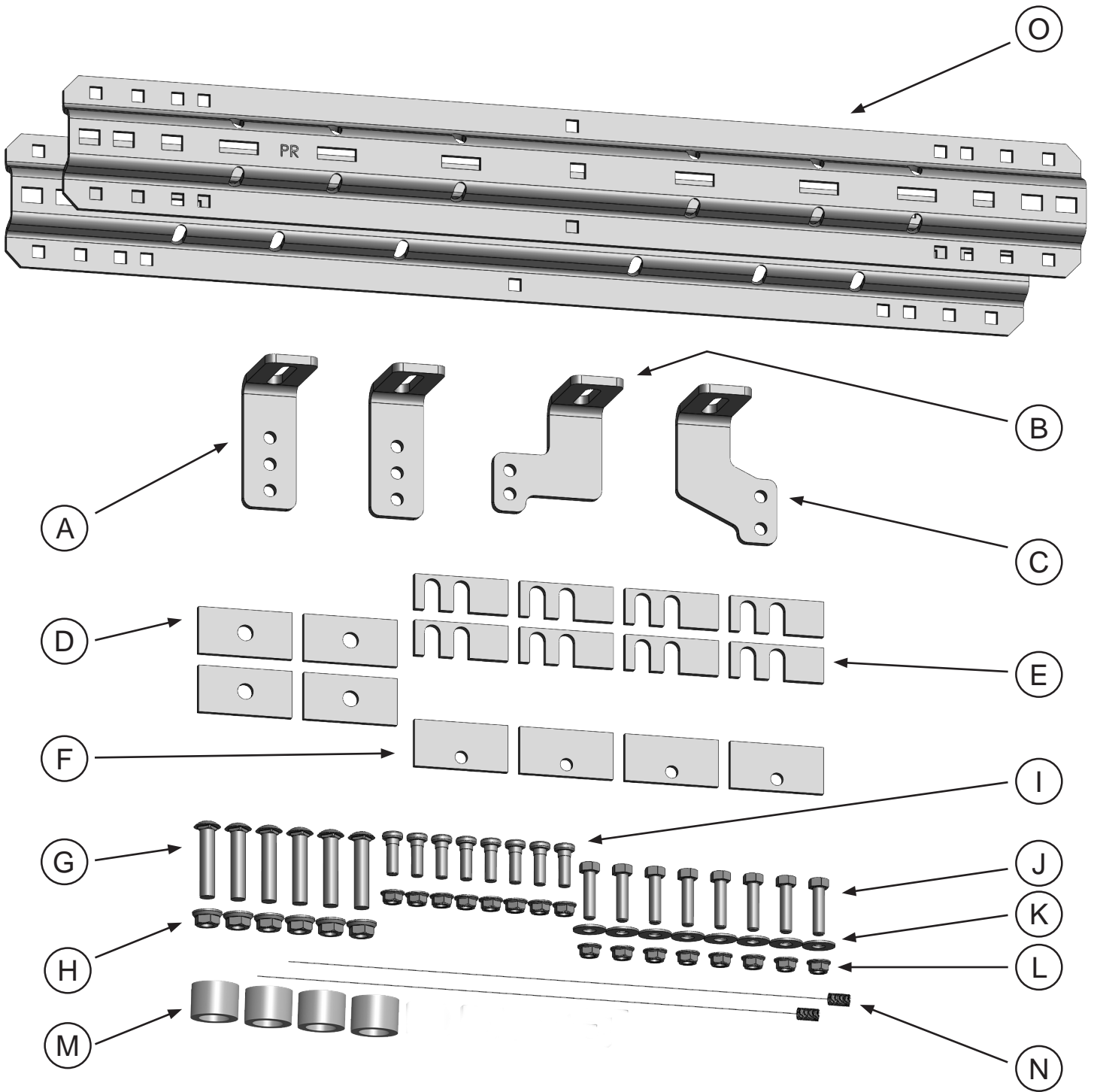

PARTS LIST

#2720 HD UNIVERSAL ISR BRACKET KIT

description	part no.	qty	material
MOUNTING BRACKET KIT	2721	1	(See kit contents listed below)
BASE RAIL KIT	2719	1	(See kit contents listed below)

#2721 — MOUNTING BRACKET KIT

item	description	part no.	qty.	material
A	STRAIGHT BRACKET	27210101	2	
B	OFFSET BRACKET - STRAIGHT CUT BOTTOM	27210102	1	
C	OFFSET BRACKET - ANGLE CUT BOTTOM	27210103	1	
	MOUNTING BRACKET HARDWARE KIT	272101	1	(See kit contents listed below)

#272101 — MOUNTING BRACKET HARDWARE KIT

item	description	part no.	qty.	material
D	CENTER HOLE BACKUP PLATE	27210203	4	5/8" CENTER HOLE SHIM
E	DOUBLE SLOTTED SHIM	27210202	8	1/2"-13 X 1-1/2" SPLINE BOLT
F	OFFSET HOLE BACK-UP PLATE	05070303	4	
G	5/8" BASE RAIL CARRIAGE BOLT	98050139	6	5/8"-11 X 3-1/2" CARRIAGE BOLT GRD 5
H	5/8" FLANGE NUT	98150200	6	5/8"-11 SERRATED FLANGE NUT
I	1/2" SPLINE BOLT	98410192	8	1/2"-13 X 1-1/2" SPLINE BOLT
J	1/2" BASE RAIL HEX BOLT	98010175	8	1/2"-13 X 2" HHCS GRD 5
K	1/2" FLAT WASHER	98250144	8	1/2" FLAT WASHER
L	1/2" FLANGE NUT	98150201	16	1/2" - 13 SERRATED FLANGE NUT
M	BASE RAIL SPACER TUBE	27210204	4	
N	1/2" BOLT LEADER	98340197	2	1/2"-13 BOLT LEADER

#2719 — BASE RAIL KIT

item	description	part no.	qty.	material
O	BASE RAILS	271901	2	

LAYOUT TEMPLATE

description	part no.	qty.	material
LAYOUT BED TEMPLATE	27200000	1	ITEM SOLD SEPARATELY

MARKING THE TRUCK BED FOR DRILLING

LAYOUT METHOD

If you purchased an installation template, please proceed to "TEMPLATE METHOD". *Templates are sold separately.*

1. Find the centerline of the bed.
2. Draw a line down the middle of the bed from front-to-rear.
3. Referencing the "Truck Bed Dimension Table," measure and mark the value for "A" from the end of the bed forward toward the cab. Do this at any point on both sides of the centerline of the bed.
4. Draw a line across the bed from mark to mark.
5. Attach the base rails to the hitch and set in the bed of the truck, checking for correct orientation (open end of the hitch plate facing outward toward the rear of the bed).
6. Place the back edge of the rear base rail along the line you made in Step 4.
7. Measure from side-to-side in the bed to ensure you are as centered as possible.
8. Proceed to the "Installation" section.

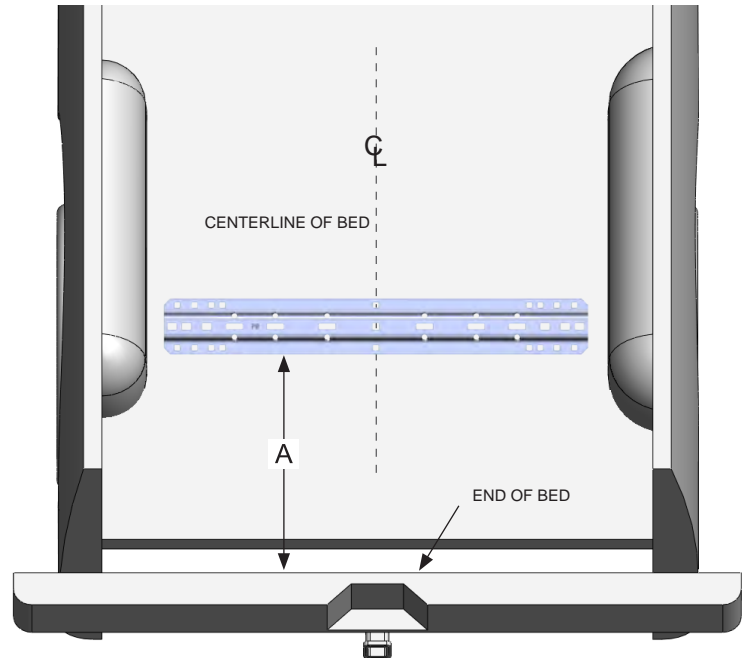

The above hole locations are for illustrative purposes only!

Refer to the Truck Bed Dimension Table below and related, vehicle-specific installation sections that follow.

TRUCK BED DIMENSION TABLE

VEHICLE	BED LENGTH	"A"	"X"	Distance Ahead of Axle
2001-2010 Chevy/GMC 2500 & 3500	6-1/2'	24-3/4"	24-3/4"	0"
	8'	29-9/16"	29-9/16"	0"
2011-2016 Chevy/GMC 2500 & 3500	6-1/2'	24-5/8"	24-5/8"	0"
	8'	29-9/16"	29-9/16"	0"
2007-2017 Chevy/GMC 1500	6-1/2'	24-7/16"	24-7/16"	0"
	8'	29-7/16"	29-7/16"	0"
2008-2016 Ford F250 & F350	6-1/2'	29-1/4"	29-1/4"	0"
	8'	29-1/4"	29-1/4"	0"
1999-2007 Ford F250 & F350	6-1/2'	29-1/4"	29-1/4"	0"
	8'	29-1/4"	29-1/4"	0"
2003-2012 Dodge 2500 & 3500 <i>(does not fit 3500 w/ overload springs)</i>	6-1/2'	26-1/8"	26-1/8"	0"
	8'	28-1/8"	28-1/8"	0"

TEMPLATE METHOD

1. Lay the template in the truck bed, centering it from side-to-side, and parallel to the end of the truck bed using the dimension "X" listed in "Truck Bed Dimension Table."
2. Mark all indicated holes specific to your vehicle's year, make and model (see Table of Contents), while making sure the template does not move.
3. Proceed to the "General Installation" section.

INSTALLATION TIPS: The **TEMPLATE** should be orientated as shown in the drawing below. To avoid drilling holes in error from out of tolerance bed-to-frame dimensions, mark the hole locations as lightly as possible if a center or transfer punch is used. Then use a very small diameter drill bit to drill one location on either side of bed. Place the Mounting Brackets against the frame to determine the correctness of the bed hole locations relative to the pre-punched holes in the Mounting Bracket and existing frame holes. Adjust the template pattern relative to the end of the bed, as necessary, to move the bed holes nearer the center of the mounting bracket holes. Note also, the information etched into the template — the direction of the cab, the template number and the revision date. As one additional measure, the template has a tendency to move when placed on the slick paint of new truck beds, and it may be helpful to place a small piece of NON-SKID matting, such as "SCOOT-GARD"™ or simply use duct tape on each corner to help keep the template from moving.

The hole locations below are for illustrative purposes only!

Refer to the Truck Bed Dimension Table below and related, vehicle-specific installation sections that follow to know what bolt hole positions to use.

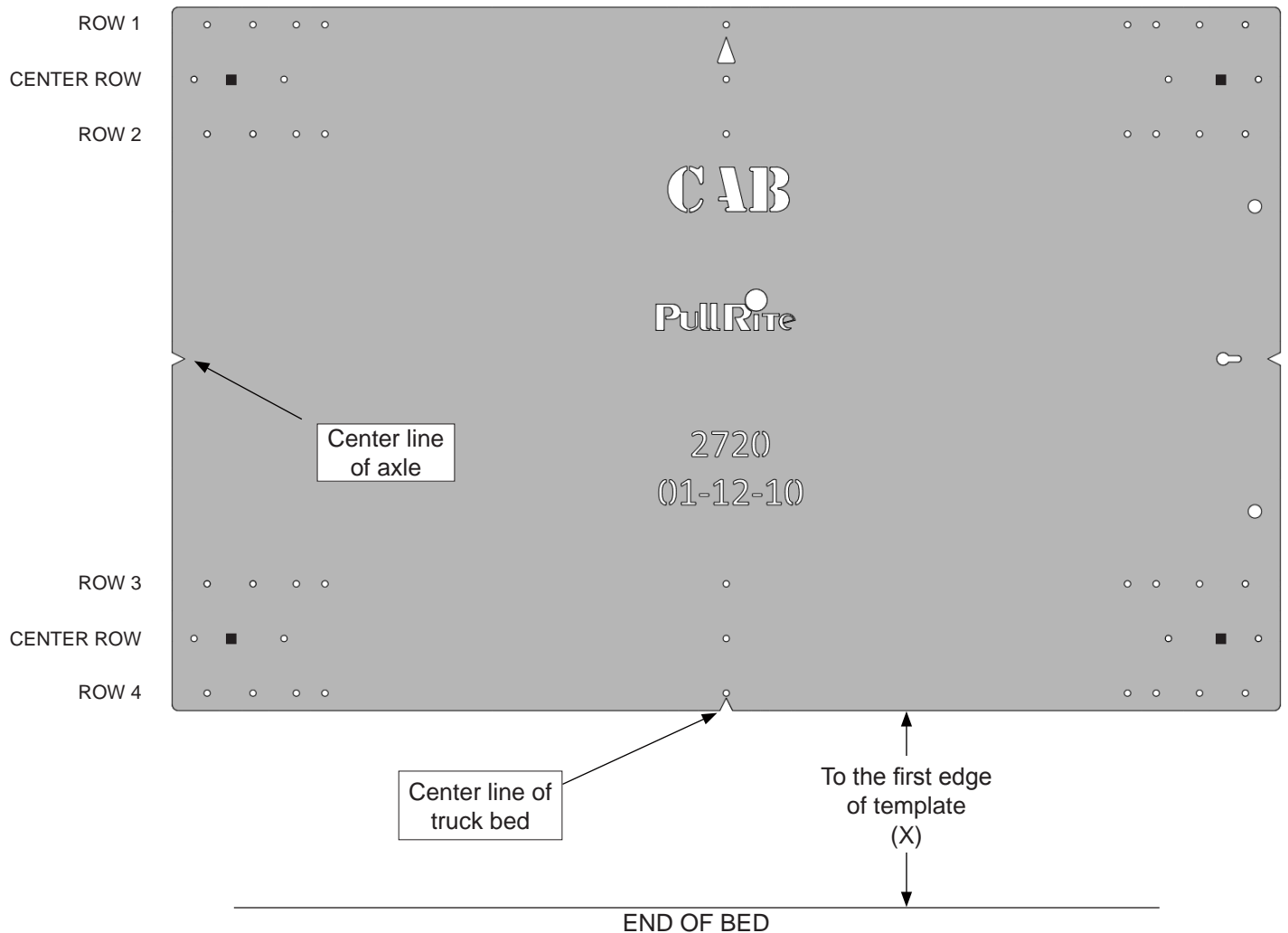

TRUCK PREPARATION

1. Check the part quantities in the Mounting Kit using the Parts List.
2. Block vehicle wheels. Some vehicles may require you to raise the rear of the truck in order to make it easier to drill for installing the mounting brackets on the truck frame.
3. Remove the spare tire and set aside.
4. You may wish to remove the wheels to give yourself greater working room.
5. Locate the Vehicle Specific Installation page on the Table of Contents page for your vehicle's year, make and model before proceeding to General Installation. You will reference these instructions and illustrations throughout the installation process.

GENERAL INSTALLATION

WARNING: We have provided the bolt hole locations specific to your vehicle on the following pages as a pre-tested guide for the best location of your new hitch; however ***it is the responsibility of the installer to confirm the validity of these specific locations.*** Vehicle manufacturers are frequently changing their frame designs, creating various obstructions such as brake lines, shock absorbers, rivets, etc. If you find such an obstruction, carefully read the instructions below as they will advise you how to maneuver around such obstructions.

1. Using a very small diameter bit (1/16" suggested), drill a pilot hole down the center of the bolt hole location that you made during "Marking the Bed for Drilling," being careful to only drill down far enough to go through the bed.
2. Leaving the bit in place, hold the driver side rear mounting bracket in position against the frame and the bottom of the bed.
 - Does the drill bit line up with the center of the horizontal slot in the Mounting Bracket?
 - If so, perform the same procedure for the other three holes where Mounting Brackets are to be positioned.
 - If not, or if it is not close enough to be usable, then adjust the location of the hitch in the bed or the selected Base Rail hole location as needed, being sure to keep the distance of the bed holes from front-to-back 22" on center and parallel with the rear edge of the bed. Repeat this procedure on all mounting brackets until you are satisfied with the results.
3. Remove the hitch or template from the bed of the truck, depending on which method you used during "Marking the Truck Bed for Drilling," and drill each of the marked hole locations, using a step drill of at least 3/4" diameter. (A step drill is a cone shaped bit that has a variety of gradually larger diameter sizes the deeper the drill is used – see right) The 3/4" holes will be covered by the Base Rails and will make the installation easier than if a 1/2" hole is used.
4. Place the hitch over the top of the drilled holes after removing the drill shavings from the bed and treating the holes with a suitable rust inhibitor.
5. Install each 5/8" Carriage Bolt {G} or 1/2" Hex Head Cap Bolt {J} through each drilled hole and Bed Rail Spacer Tubes {M} to fill the bed channel (spacers prevent the bed channels from collapsing when the bolts are tightened). See your vehicle-specific installation notes and illustrations to help you determine bolt choice and spacer placement, noting the WARNING above.

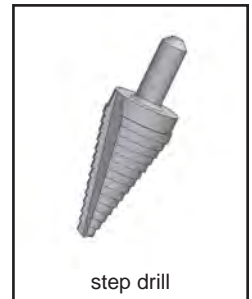

Note: The bolts in the center of the bed rail (left to right), where applicable, do not require spacer blocks or bed shims.

6. Install the appropriate Backup Plates {F} and Shims {E} *underneath* the truck bed to prevent crushing the bed channels. The center hole bolts of the base rail (if required; reference your vehicle-specific instructions) require a Center Hole Backup Plate {D} installed under the truck bed for support. The backup plates are simply large washers meant to provide a larger surface contact than a standard flat washer; the Offset Hole Backup Plate {F} is provided where clearance around obstacles is a problem.
7. Clamp each Mounting Bracket flush to the side of the frame.

WARNING: Before drilling, check the inside of the frame to guard against drilling into wiring or lines. Be sure to protect the fuel tank from possible puncture.

8. Select the appropriate pre-punched holes of the mounting bracket, referring to the illustrations on your vehicle-specific installation notes, and drill two 17/32" holes in the frame for each Mounting Bracket using the holes as a guide. It is important that the holes are 17/32" in diameter; if the holes are too small, the bolt can break, and if the holes are too large, the bolt cannot grip properly.

GENERAL INSTALLATION

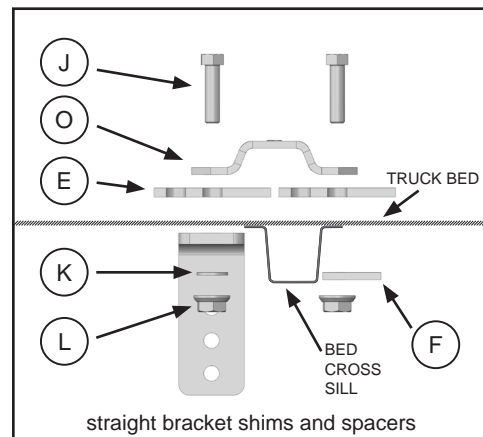
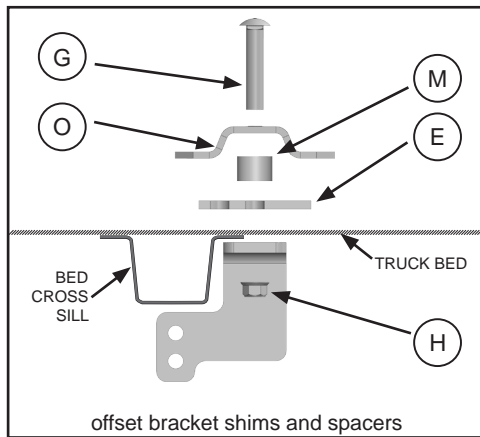

The above hole, shim and spacer locations and selection are for illustrative purposes only! Shims and spacers are used to support the truck bed where gaps caused by the corrugated truck bed are present between the brackets and base rails. Refer to your vehicle-specific notes and illustrations.

9. Depending on the make and model of your truck, the truck frame may be partially or entirely enclosed (see example below). To install the 1/2" Spline Bolts {} in an enclosed frame, they must be "fished" through the frame. With the bracket clamped in place, thread a long fish wire (not provided) through any of the holes you've drilled out, threading the wire rearward to the end of the frame.
10. Once the wire reaches the rear frame opening, bend the end of the provided bolt leader to make an eyelet, and attach the fish wire to the leader.

Installation Tip: Prior to threading the spline bolt into the leader, thread the 1/2" Flange Nut {} on and off the bolt to assure that the nut will fit easily once the bolt is in place.

11. Thread a spline bolt into the provided bolt leader and pull it through the drilled hole.

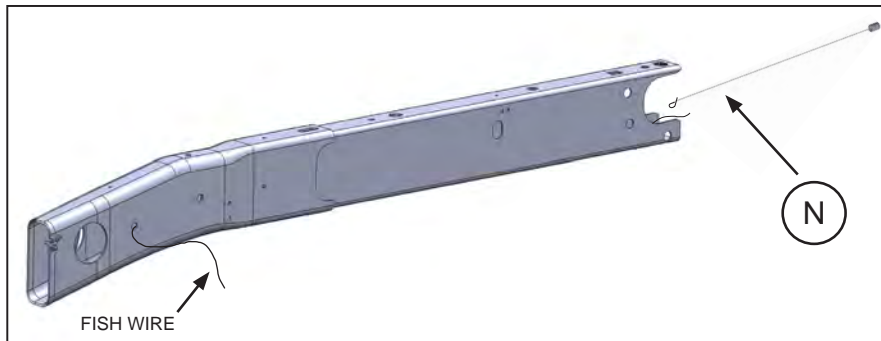

TORQUE TABLE	
3/8" bolt	— 31 ft. lbs.
1/2" bolt	— 75 ft. lbs.
9/16" bolt	— 109 ft. lbs.
5/8" bolt	— 151 ft. lbs.
3/4" bolt	— 266 ft. lbs.

12. Fasten each Mounting Bracket to the frame using two 1/2" Flange Nuts {} for each bracket and hand-tighten.
13. With the hitch assembled on the rails, maximize the distance between the rails (move the front rail forward, and back rail rearward) and tighten the mounting bracket bolts according to the Torque Table. Maximizing the distance between the rails before tightening should reduce movement between the hitch and rails. Be sure not to separate the rails so much that the hitch is difficult to take on and off the rails.
14. Fasten all hardware to their appropriate torques as indicated on the Torque Table above.

1999-2007 FORD F250 & F350

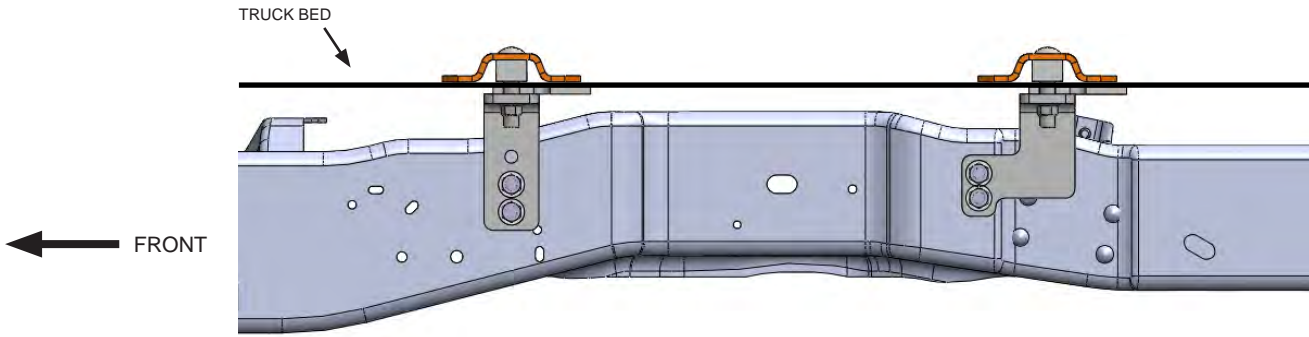

Driver Side View

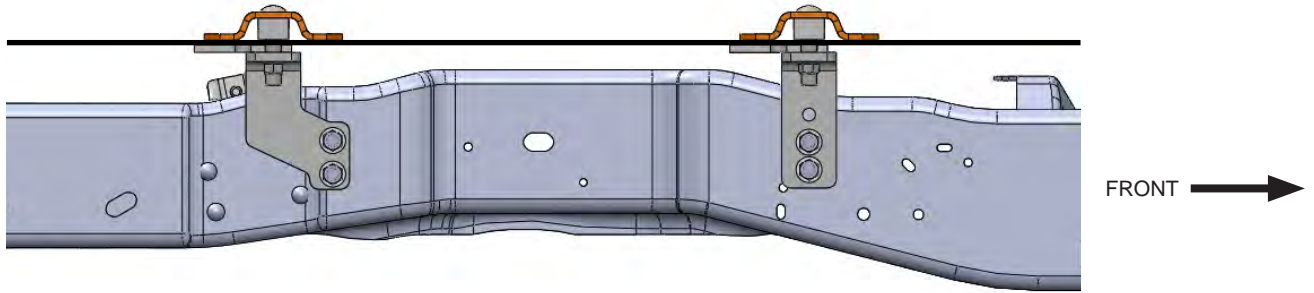

Passenger Side View



Brackets FACE OUT

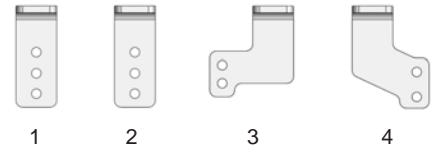

1. Driver Side Front
2. Passenger Side Front
3. Driver Side Rear
4. Passenger Side Rear

VEHICLE SPECIFIC INSTRUCTIONS

1. When installing the Bed Channel Spacer between the Mounting Bracket and the bed, use the offset slot to avoid interference with the cross sill (reference illustrations on page 9). The front center bolt is required for 20K applications only.

2008-2016 FORD F250 & F350

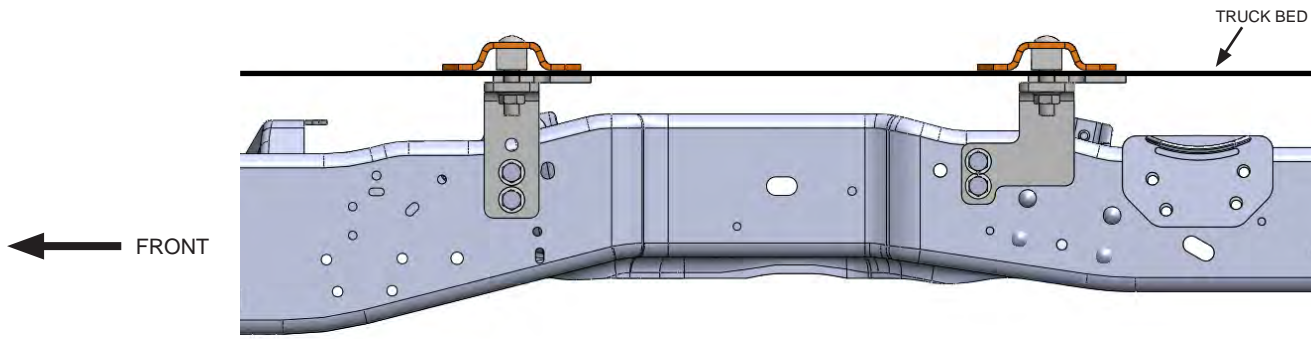

Driver Side View

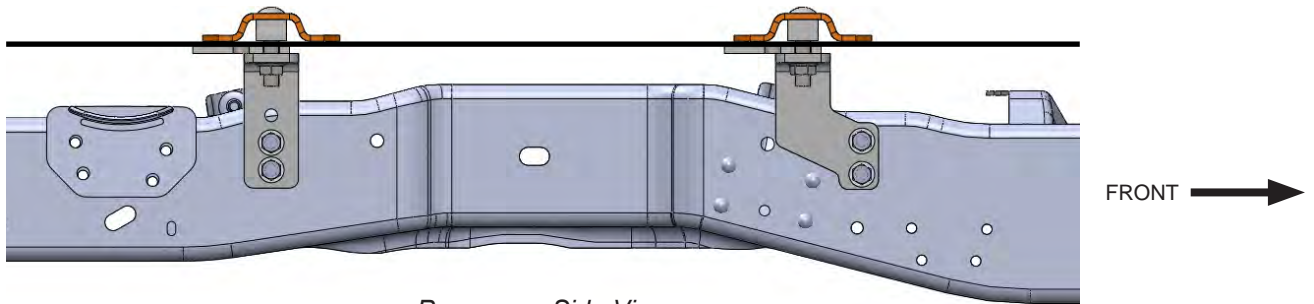

Passenger Side View



Brackets FACE OUT

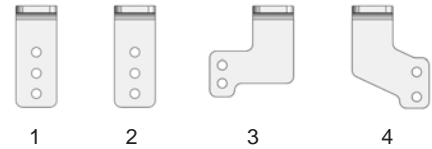

1. Driver Side Front
2. Passenger Side Rear
3. Driver Side Rear
4. Passenger Side Front

VEHICLE SPECIFIC INSTRUCTIONS

1. When installing the Bed Channel Spacer between the Mounting Bracket and the bed, use the offset slot to avoid interference with the cross sill (reference illustrations on page 9). The front center bolt is required for 20K applications only.

2001-2010 CHEVY/GMC 2500 & 3500

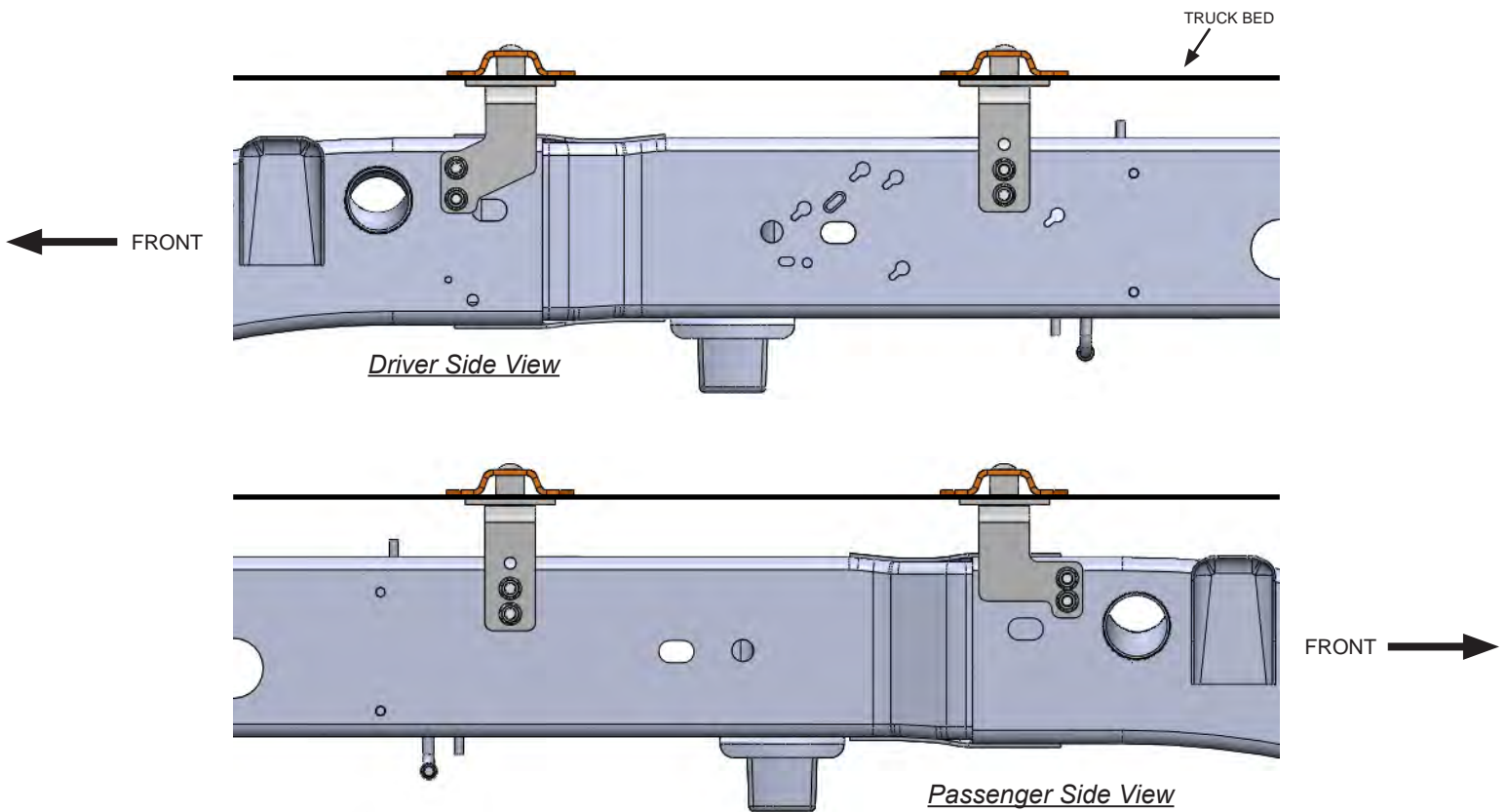

Brackets FACE IN

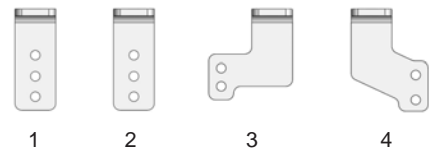

1. Driver Side Rear
2. Passenger Side Rear
3. Passenger Side Front
4. Driver Side Front

VEHICLE SPECIFIC INSTRUCTIONS

1. Frame bolts for the front mounting brackets must be fish wired into position with 1/2" Pull Wire. The front center bolt is required for 20K applications only.

2011-2016 CHEVY/GMC 2500 & 3500

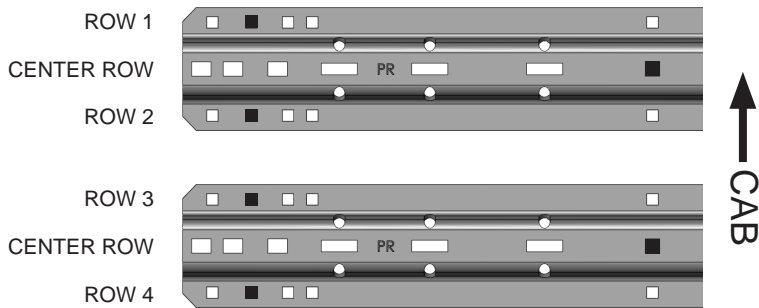
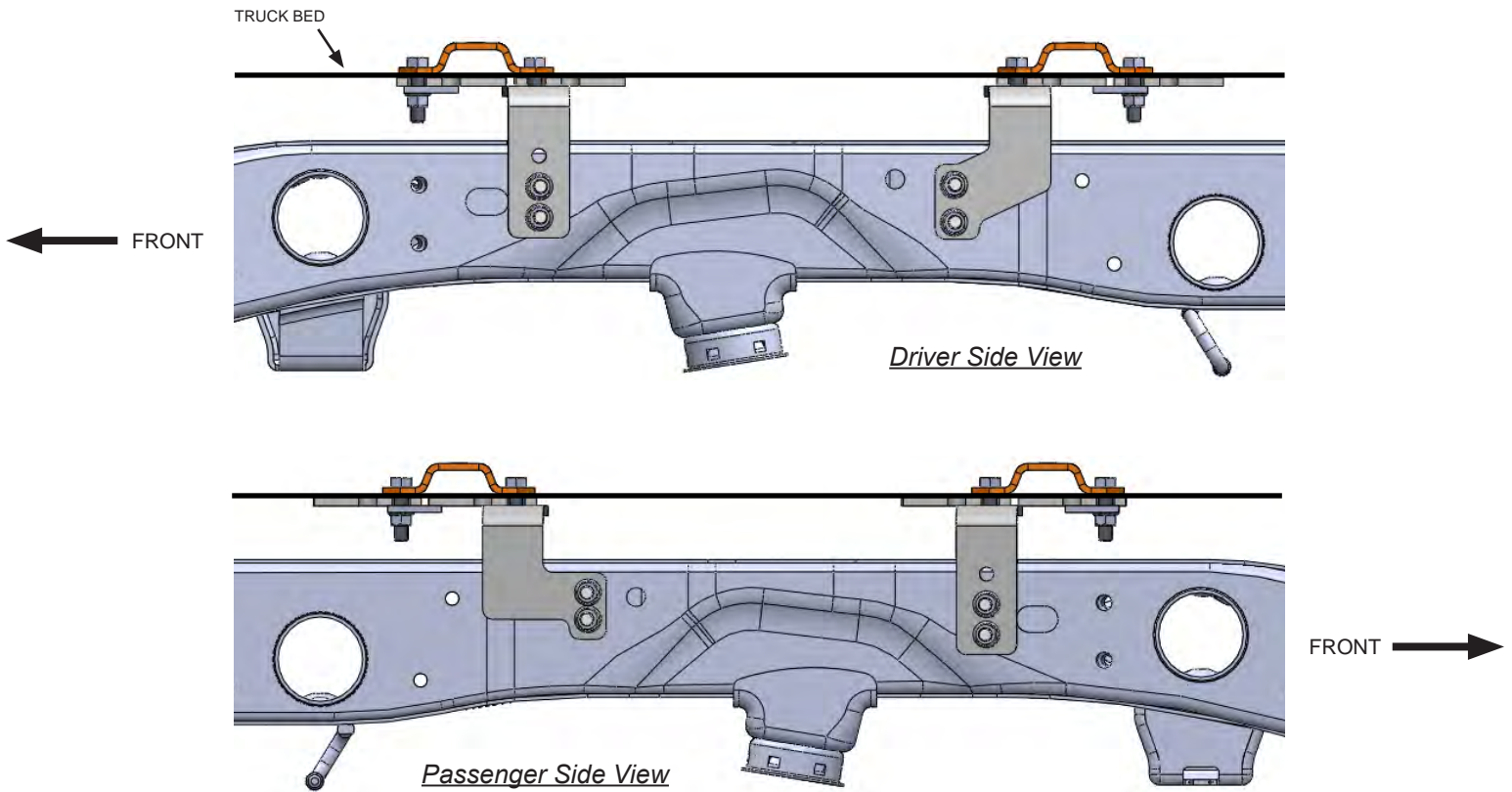

Brackets FACE IN

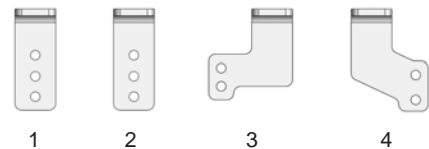

1. Driver Side Front
2. Passenger Side Front
3. Passenger Side Rear
4. Driver Side Rear

VEHICLE SPECIFIC INSTRUCTIONS

1. Frame bolts for the mounting brackets must be fish wired into position with 1/2" Pull Wire. The bracket slots are sized for 5/8" bolts so be sure to use a 1/2" Harden Steel Washer between the slotted side of the mounting bracket and the flange nut. The front center bolt is required for 20K applications only.

2007-2017 CHEVY/GMC 1500

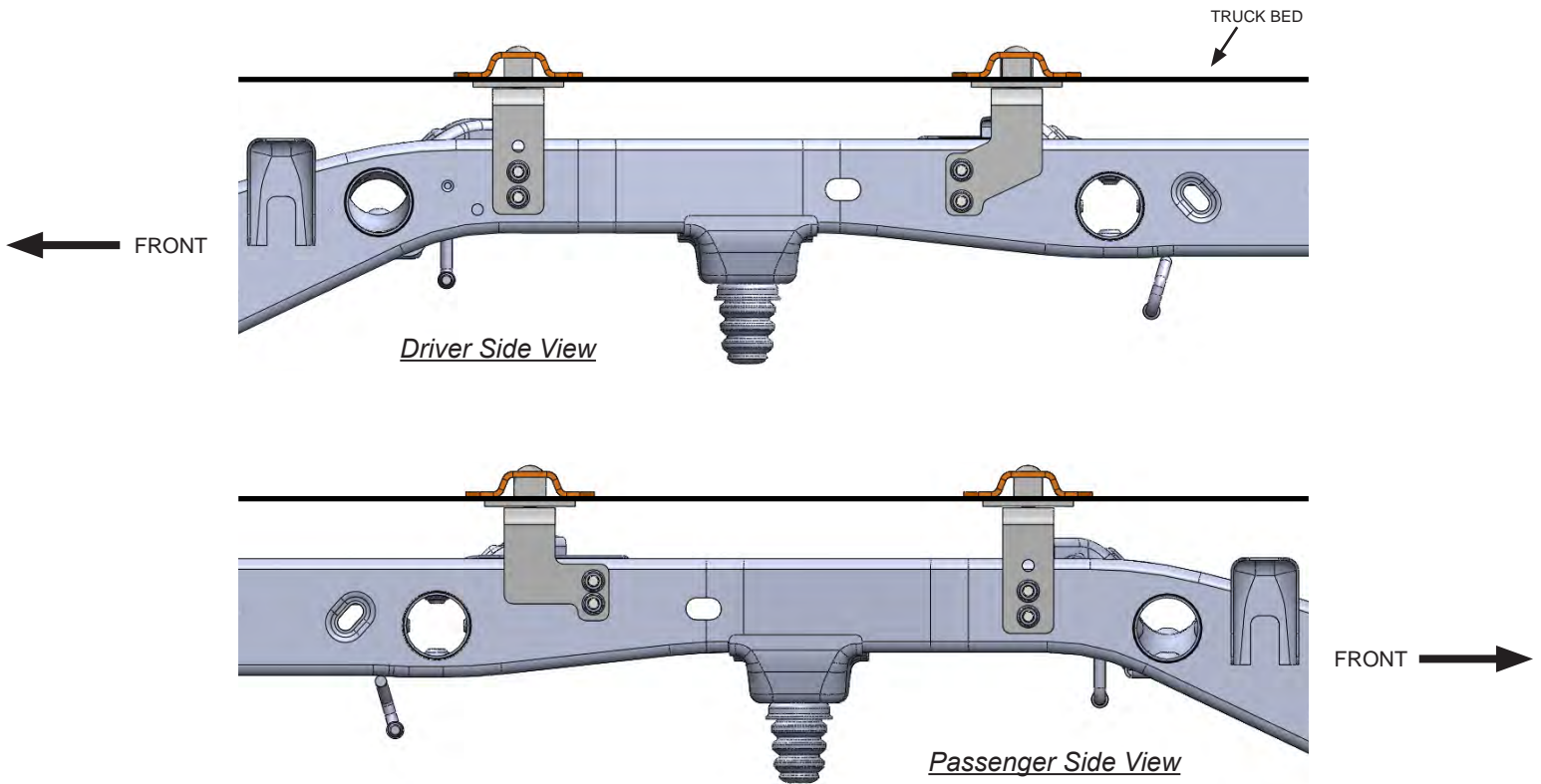

Brackets FACE IN

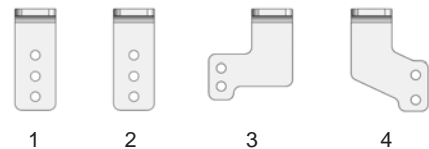

1. Driver Side Front
2. Passenger Side Front
3. Passenger Side Rear
4. Driver Side Rear

VEHICLE SPECIFIC INSTRUCTIONS

1. Frame bolts for the mounting brackets must be fish wired into position with 1/2" Pull Wire. The front center bolt is required for 20K applications only.

2003-2012 DODGE 2500 & 3500 (WITHOUT OVERLOAD SUPPORTS)

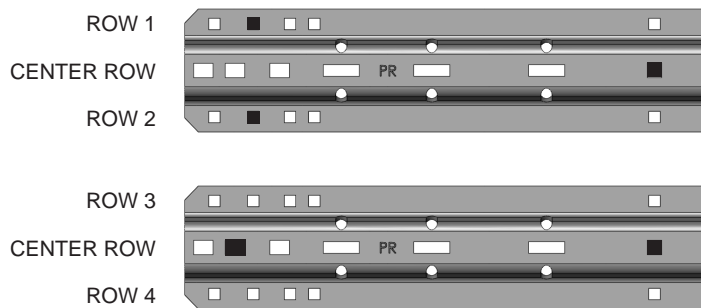
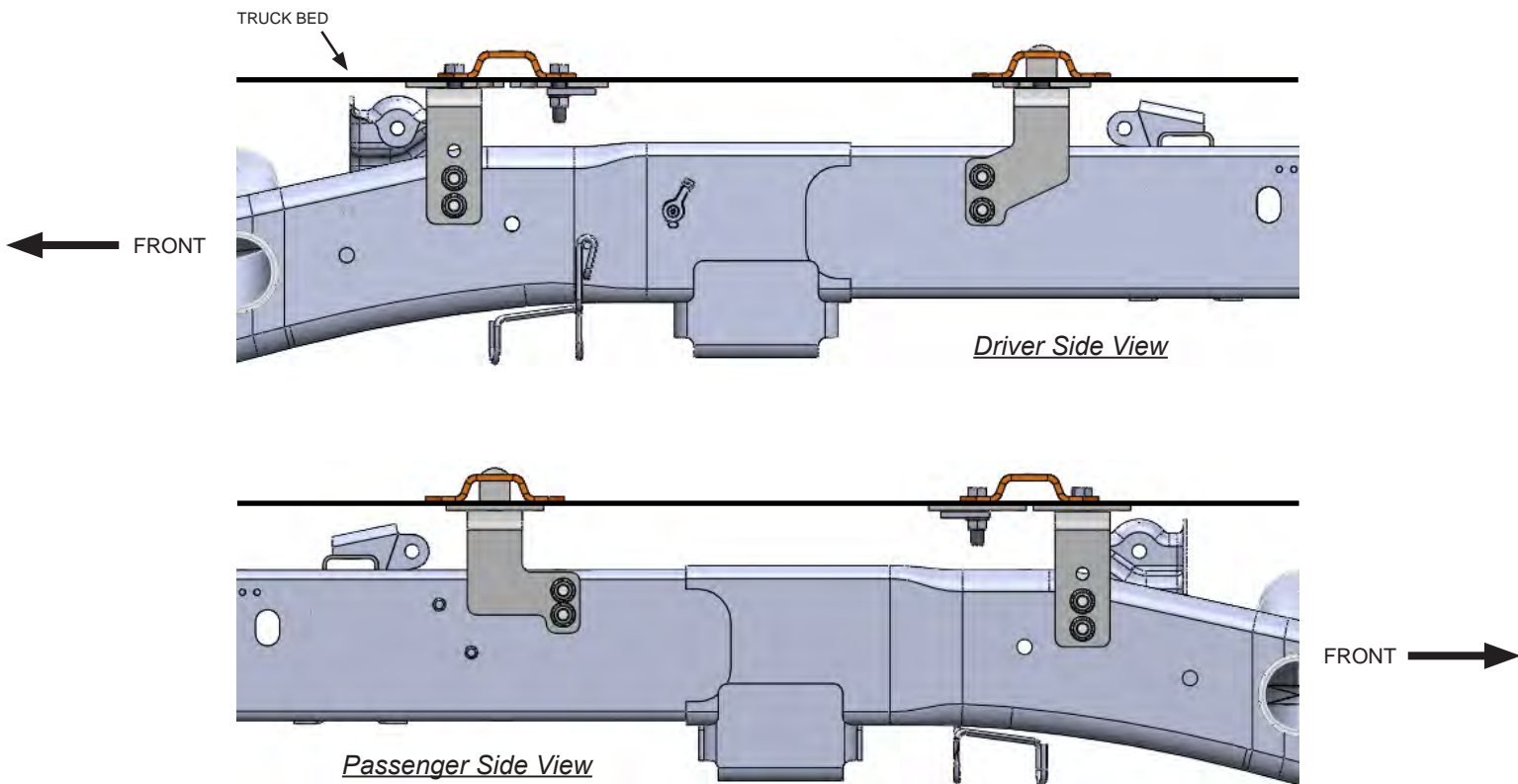

Brackets FACE IN

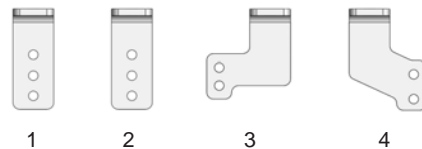

1. Driver Side Front
2. Passenger Side Front
3. Passenger Side Rear
4. Driver Side Rear

VEHICLE SPECIFIC INSTRUCTIONS

1. Reference the outside slot install the illustrations on page 9 when installing the 1/2" Hex Bolts through the both rails and bed. The bracket slots are sized for 5/8" bolts so be sure to use a 1/2" Harden Steel Washer between the slotted side of the mounting bracket and the flange nut. All frame bolts must be fish wired into place through an opening on the bottom of the frame. The front center bolt is required for 20K applications only.



MANUFACTURED BY:
PULLIAM ENTERPRISES, INC.
13790 East Jefferson Blvd.
Mishawaka, IN 46545
(574) 259-1520 • (800) 443-2307
info@pullrite.com • www.pullrite.com