



FORD

SuperBracket Mounting Kit

#0822



#1200 SuperGlide
(16K)

Gross Trailer Weight (Maximum) 16,000 lbs.
Vertical Load Weight (Max. Pin Weight) 4,000 lbs.



#0800 SuperGlide
(20.5K)

Gross Trailer Weight (Maximum) 20,500 lbs.
Vertical Load Weight (Max. Pin Weight) 5,125 lbs.

Installation Instructions

SPECIFICATIONS

- Fits 1999-2015 Ford F250 & F350
- Hitch is located 1.55" ahead of axle
- Custom Mounting Bracket Kit (*Bracket & Hardware*) #0810

Table of Contents

	<u>PAGE #</u>
#0800 - Parts List	3
#1200 - Parts List	4
Parts List for Custom Mounting Bracket & Tools Needed	5
Super 5th & Vehicle Preparation / Layout & Marking Bed	6
Installation Tips & Drilling the Bed & Hitch Assembly	7
Hitch Assembly (cont.) & Hitch Installation	8
Illustrations & General Comments	9

Parts List For 20,500 Super 5th Hitch

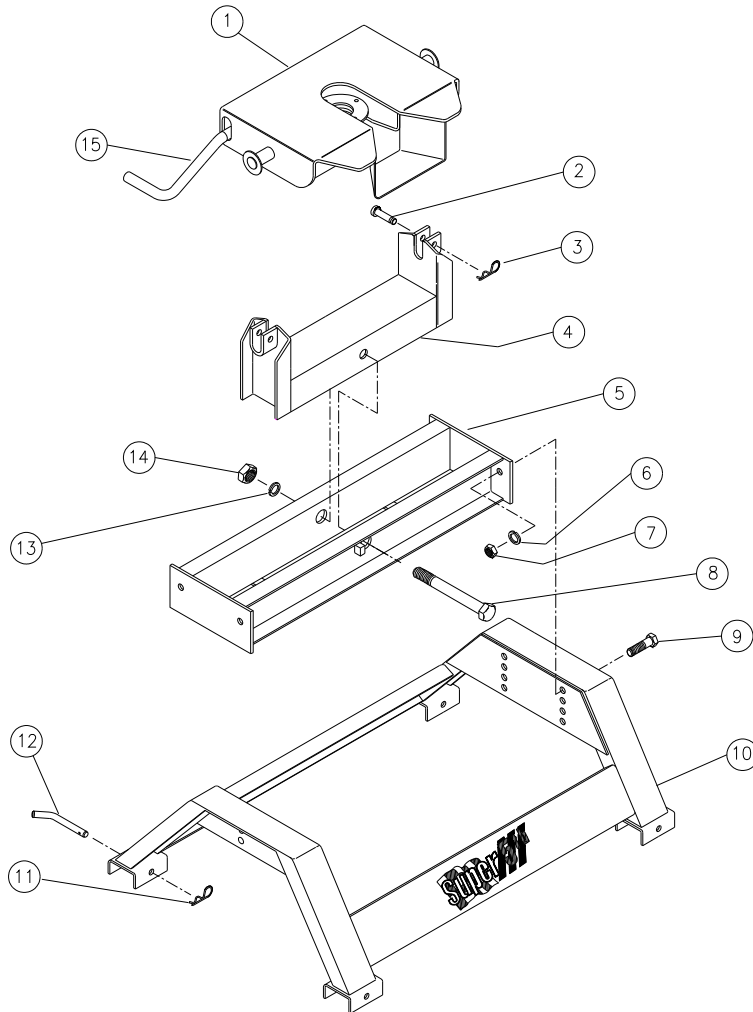

Ref	Item	Part #	Qty
1.	Fifth Wheel Plate	3601	1
2.	1/2 Clevis Pin	98410111	2
3.	#3 Pin Clip	98410127	2
4.	Rocker Arm	0802	1
5.	Crossmember	0803	1
6.	1/2" Lock washer	98200142	4
7.	1/2"-13 Hex Nut	98150153	4
8.	3/4" x 7" Pivot Bolt	98010147	1
9.	1/2"-13 x 1 1/2" Bolt	98010167	4
10.	Base	0804	1
11.	#3 Pin Clip	98410127	4
12.	1/2" Base Rail Pin	08060001	4
13.	3/4" Lock washer	98200124	1
14.	3/4"-10 Hex Nut	98150131	1
15.	Release Handle	350104	1

Parts List For 16,000 Super 5th Hitch

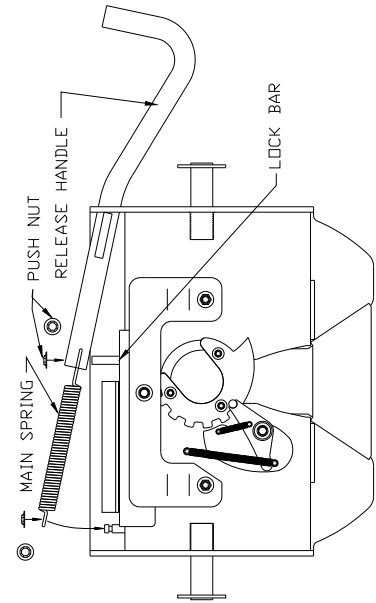
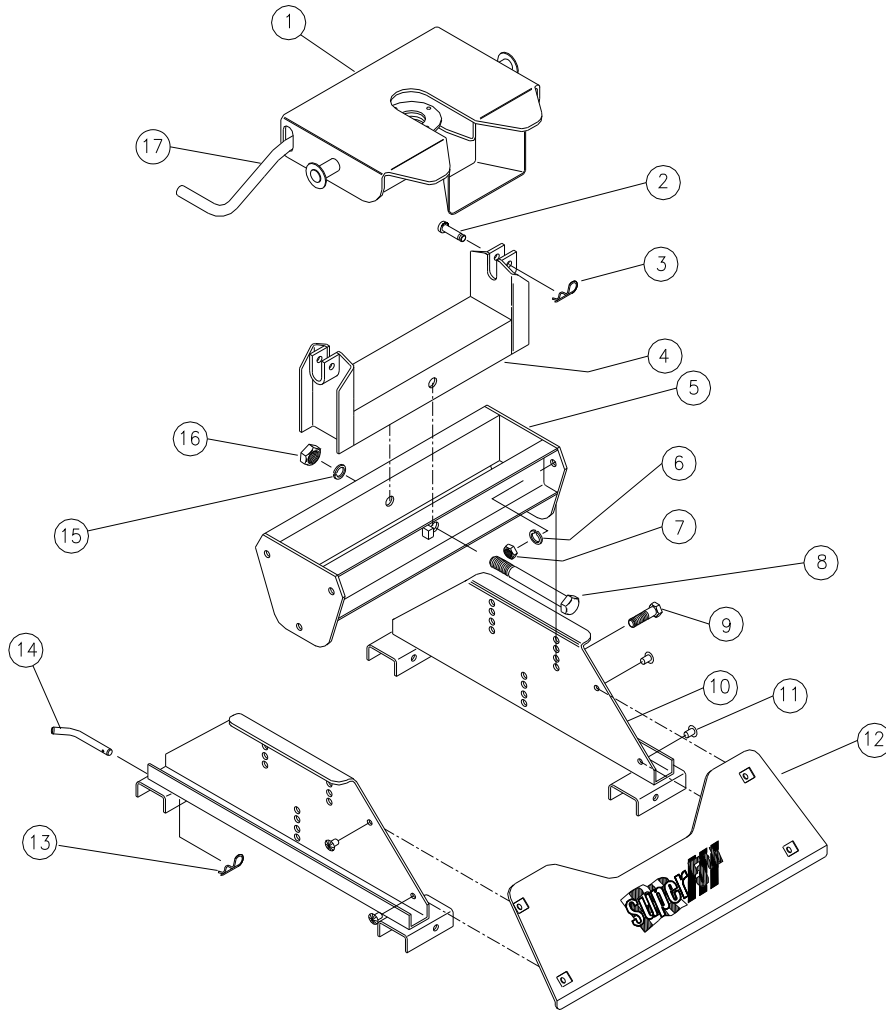

Ref	Item	Part #	Qty
1.	Fifth Wheel Plate	3601	1
2.	1/2" Clevis Pin	98410111	2
3.	#3 Pin Clip	98410127	2
4.	Rocker Arm	0802	1
5.	Crossmember	1202	1
6.	1/2" Lock washer	98200142	6
7.	1/2"-13 Hex Nut	98150153	6
8.	3/4" x 7" Pivot Bolt	98010147	1
9.	1/2"-13 x 1 1/2" Bolt	98010167	6
10.	Base Side	120301	2
11.	Plastic Xmas Tree		4
12.	Base Cover	120302	1
13.	#3 Pin Clip	98410127	4
14.	1/2" Base Rail Pin	08060001	4
15.	3/4" Lock washer	98200124	1
16.	3/4"-10 Hex Nut	98150131	1
17.	Release Handle	350104	1

Parts List For Ford Super 5th Custom Mounting Kit

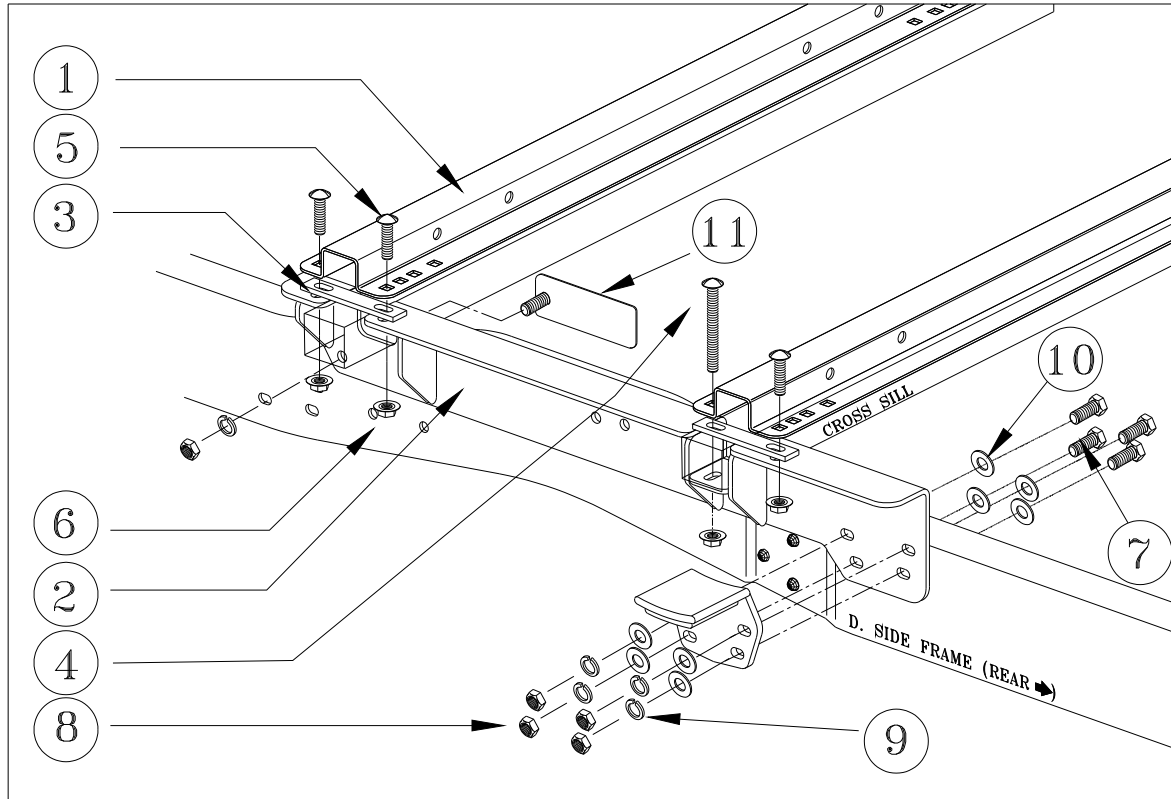

Figure 1

Ref.	Item	Part #	Qty
1.	Base Rail	08050001	2
2.	Mounting Brackets	0810	1 set
3.	Bed Channel Spacer [dbl. slot, 1/4" x 1" x 6"]	05070301	4
4.	1/2"-13 x 5" Carriage Bolt	98050128	2
5.	1/2"-13 x 2" Carriage Bolt	98050110	6
6.	1/2"-13 Flange Nut	98150201	8
7.	1/2"-13 x 1-1/2" Frame Bolt	98010167	9
8.	1/2"-13 Hex Nut	98150153	10
9.	1/2" Lock Washer	98200142	10
10.	1/2" Flat Washer	98250145	16
11.	1/2"-13 x 1-1/2" Frame Bolt (w/back-up plate)	081004	1
	Custom Mting Brkt. Set (Brkts & Hardware)	0810	
	Hardware Kit (Fasteners & Spacers)	081003	
	Custom Mounting Kit (Brkts, Rails & Hardware)	0822	

Tools Needed For Installation

1/2" Drill Motor	3/4" Socket	1/2" Drive Impact Gun or 1/2"
1/16" Drill Bit	1 1/8" Socket	Drive Ratchet Wrench 3/4"
1/8" Drill Bit	Torque Wrench	Combination Wrench
1/2" Drill Bit	Measuring Tape	Felt Tipped Marker
3/4" Step Drill Bit		Hammer

Vehicle Preparation

1. After blocking the front wheels, place jack stands under the frame so that the rear of the truck is high enough to allow the rear wheels to drop. This will give easy access to the frame area in the rear wheel well.
2. Remove the spare tire. This will allow easy access to the inside of the truck frame. The fender support at the front of the wheel well may also need to be removed, in order to drill front hole location.
3. Drill out to 9/16" the small hole located just above and to the right of the front overload bumper bracket. (see figure 4 page 6)
4. Unfasten the bolt (15 mm) that holds the emergency brake cable to the frame on the drivers side.

Laying Out and Marking the Bed

Template method to mark bed:

1. Place the rear edge of the template 29-1/2" forward of the rear edge of the truck bed.
2. Center template in bed from left and right. Lineup the etched centerline with the centerline of the truck bed.
3. While standing on the template, use a 1/16" drill bit to mark the bed at each hole location indicated (See figure 2 this page).

Ask your distributor sales representative about hole pattern templates (P/N: 0899).

Layout method to mark bed:

Using the dimensions shown below (fig. 3), draw layout lines in the bed using a straight edge and marker or chalk line. At intersections of dashed lines, use a center punch to mark the bed.

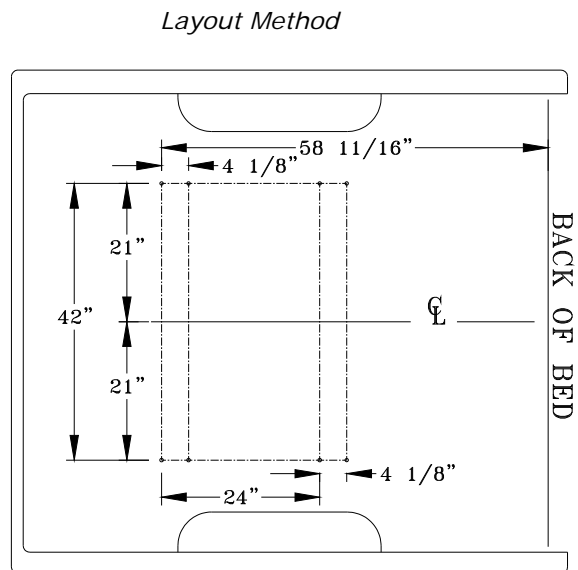
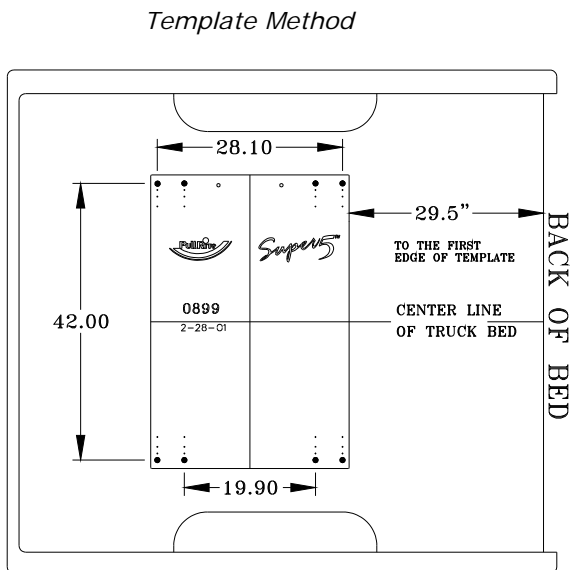

Installation Tips

To avoid drilling holes in error from out of tolerance bed to frame dimensions, mark the hole locations as lightly as possible if a center or transfer punched is used. Then use a very small diameter drill bit to drill one location on either side of bed. Place brackets against frame to determine the correctness of the bed hole locations relative to the pre-punched holes in the mounting bracket (See figure below). Adjust the lay out or template pattern relative to the end of the bed, as necessary, to move the bed holes nearer the center of the mounting bracket holes.

Installers can keep a record of the adjustments that are found necessary to properly locate the bed holes. PullRite has performed numerous installations to develop these lay out dimensions, but encourages installers to satisfy themselves as to their accuracy. PullRite recommends using 3/4" holes through the bed to help accommodate tolerance variances that occur in the vehicle assembly. Experienced installers using PullRite custom brackets have been able to skip this step after several installations of a given model of truck.

Figure 4

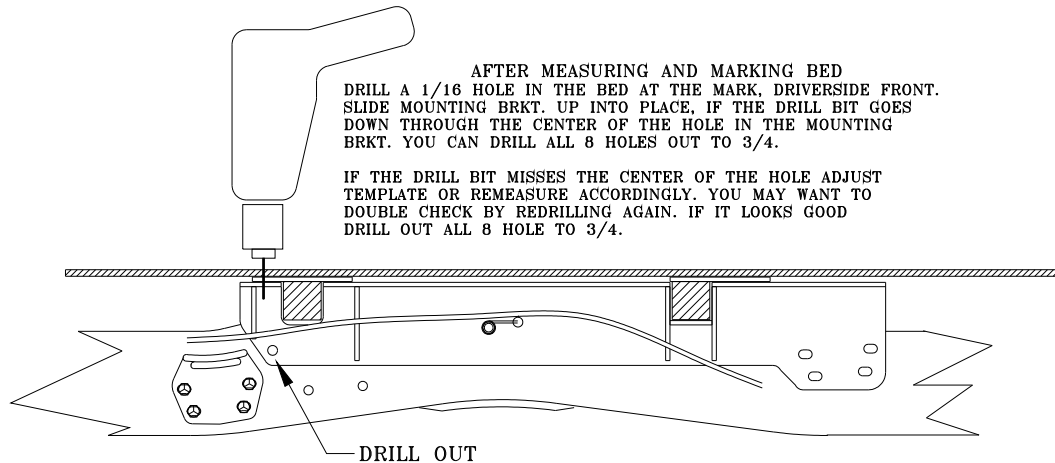

Drilling the Bed

1. Check all hole locations for any fuel lines or tanks and wiring that could become damaged in the drill process.
2. Once the bed hole pattern location is satisfactory, center punch all hole locations. Or for template method drill 1/16" holes at each location on the template (see figure 2 page 5)
3. Drill all hole locations using a 3/4" drill bit. A step drill works best for drilling sheet metal.
4. Remove drill shavings from the bed and treat the raw edges of drill holes with a rust inhibitor.

Hitch Assembly

Hitch Assembly for 20,500#:

If the hitch type to be installed is a 20,500# (Part #0800), there is no assembly required except to attach the Base Rails to the base feet of the hitch Base using the four 1/2" Base Rail Pins and four #3 Pin Clips (See exploded drawing on page 2).

This hitch has four height settings and should be adjusted according to the directions found in the Operators Instructions found in the same box as the hitch. Be sure to torque all four 1/2" x 1-1/2" Bolts to 75 foot pounds.

Hitch Assembly Cont.

Hitch Assembly for 16,000#:

If the hitch type to be installed is a 16,000# (Part #1200), it will be necessary to assemble the hitch first. Refer to page 3 and the exploded view of this hitch and the parts list below the drawing and follow these steps:

1. Arrange the Base Rails parallel to each other and attach the Base Sides using the four 1/2" Base Rail Pins and four #3 Pin Clips.
2. Remove the 3/4" x 7" Pivot Bolt from the Rocker Arm and Crossmember.
3. The Rocker Arm is shipped upside down in the Crossmember for better packaging and will need to be removed and reinstalled right side up in the Crossmember as shown in the exploded view drawing on page 3. Tighten the 3/4" x 7" Pivot Bolt only enough to flatten the 3/4" Lock Washer or enough so that the Rocker Arm will rotate stiffly. Lubricate the 3/4" Pivot Bolt with heavy grease before installing.
4. Fasten the Crossmember and Base Sides together using six each of the 1/2"-13 x 1 1/2" Bolts, 1/2" Lock Washers and 1/2"-13 Hex Nuts, tighten bolts to 75 foot pounds. This hitch has four height settings and should be adjusted according to the directions found in the Operators Instructions found in the same box as the hitch.
5. Fasten the Fifth Wheel Plate in the Rocker Arm using two each of the 1/2" Clevis Pins and #3 Pin Clips after installing the Release Handle and Main Spring as shown in Plate drawing on page 3.

Hitch Installation

(read instructions once completely before beginning actual installation)

1. Install Bed Channel Spacers directly below the mounting holes drilled in the bed. These spacers will pass between the bottom of the bed and the top of the bed cross sills, see figure 5 on page 8. These spacers may have to be tapped into place with a hammer.
2. Set the hitch assembly in the bed so that the first set of square holes from the end of the Base Rails line up with the holes drilled in the bed.
3. Referring to figure 5 on page 8 and the exploded view figure 1 on page 4, insert the six 1/2" x 2" Carriage Bolts through the Base Rail, bed and Bed Spacers.
4. Referring to figure 5 on page 8 and the exploded view drawing figure 1 on page 4, fit the Mounting Brackets over the Carriage Bolts and insert the 1/2" x 1 1/2" Frame Bolt through the forward hole in the Mounting Bracket and the frame. This hole will have to be drilled for 6 foot bed trucks while for 8' bed trucks there is an existing hole in the frame but is under sized and will need to be reamed out to 1/2". Because of the fuel tank located on the driver's side, the 1/2" Hex Bolt with Back-up Plate will have to be used. This will provide a handle with which to reach this difficult hole location and will also provide a means for "back-up" when tightening the fastener.

NOTE: For 2011-2012 Ford Diesel trucks, there are two holes at the front of the bracket. The large hole serves as a clearance hole for a bolt in the frame on the *drivers side only*, and the small hole to an existing hole on the frame.

1. If the vehicle is equipped with over load springs, the same fasteners used to originally mount the over load bumpers can be used to fasten the rear of the Mounting Bracket and the over load bumper, see figure 1 on page 4. If the vehicle is not equipped with over load springs then the holes in the frame must be drilled out using a 1/2" drill bit.
2. To reattach the emergency brake cable and bracket, insert the original brake cable bolt through the forward most hole located in the center of the Mounting Bracket with the threaded end pointing outwards (the bolt does not go through the frame, only the Mounting Bracket). Replace the brake cable bracket in the same manner that it was originally installed in the frame and refasten using the original nut.
3. Fasten the Mounting Brackets to the frame using the 1/2" x 1 1/2" Hex Bolts provided and then torque all 1/2" bolts through the frame to 75 foot pounds.
4. Using the square hole in the Base Rail as a guide and using a 1/2" drill bit drill the bottom of the cross sill located at the rear of the Mounting Bracket and insert the two 1/2"-13 x 5" Carriage Bolts.
5. Using eight 1/2" Flanged Nuts provided, fasten all of the carriage bolts and torque to 75 foot pounds.

Installation Tips

Make sure that all of the Carriage Bolts are hanging straight down. If they are not, remove the Carriage Bolt and run a 1/2" drill bit through the hole so that they will. Bolts that do not hang straight may cause the Base Rails to shift and, in turn, make the removal and reattachment of the base more difficult.

Caution: As there is a void in the cross sill, when tightening the 5" Carriage Bolt, do not tighten to 75 foot pounds if the bed and Base Rail begins to "pull down".

General Comments

First installations of any product usually take longer than if they were practiced. Keeping a record of measurement adjustments for each vehicle, make, and model will speed future installations and aid others who are training to install hitches. For installers who are interested in a hole pattern template, contact your PullRite distributor sales representative. If you have any installation questions, contact PullRite customer service at 800/443-2307.

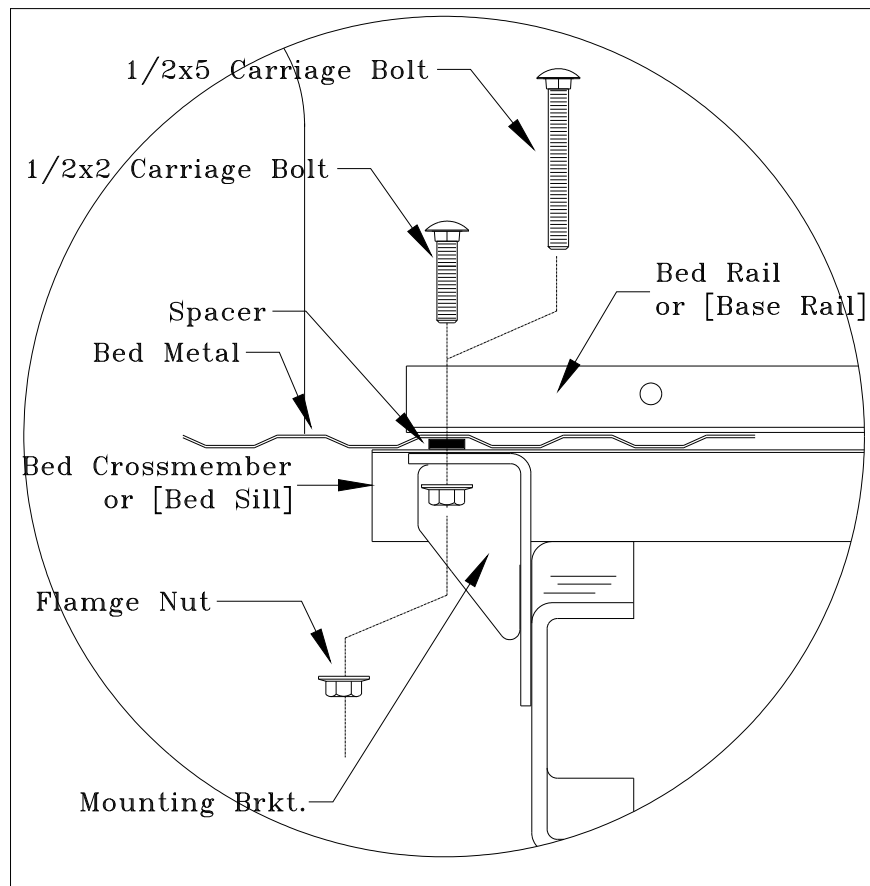

Figure 5