



1999-2011 Ford F250 & F350 SuperRail Mounting Kit #3513



Installation Instructions

SPECIFICATIONS

- Does NOT fit 2011 Ford Diesel models
- Hitch is located 1" ahead of axle

IMPORTANT

DO NOT OPERATE HITCH UNTIL YOU READ THIS SECTION!

The SuperGlide hitch was designed to allow the Turntable Cam Arm Assembly to “glide” along two metal tubes, called the Way Tubes. Since it's release in 1998, we have made several advancements in the design, strength, and durability of these components. The Lubrication section of your Owners Manual spans several product releases and design changes. It is *imperative* that you read each section and determine which SuperGlide hitch you purchased, and how to care for it. There have been three major lubrication changes to the SuperGlide hitch:

Prior to April 2008, Way Tubes were assembled with either a conventional, quality grade grease or none at all

In April 2008, we started coating the Way Tubes with a graphite-based spray lubricant called SlipPlate™

November 2009 brings a new innovation from PullRite Towing Systems with the use of plastics. The Turntable Cam Arm Assembly is now equipped with Plastic Wear Plates; see Owners Manual for details (not available for #3600 models)

Depending on when your hitch was manufactured, the Way Tubes of your new SuperGlide hitch will meet one of the above criteria. Each application listed requires some level of maintenance, so it is important that you read the following instructions carefully for the correct lubrication instructions.

Failure to properly lubricate the Way Tubes, as directed in this section, will eventually cause galling between the metals of the Way Tubes and Cam Arm Assembly, which will result in hitch failure.

Destruction of various hitch parts is also likely, as well as truck and/or trailer damage, and will not be covered under the Manufacturer's Warranty.

THE TRAILER'S KING PIN BOX MUST BE EQUIPPED WITH A CAPTURE PLATE (UNIVERSAL OR QUICK CONNECT) TO ALLOW THE HITCH TO FUNCTION (MUST BE PURCHASED SEPARATELY). NOTE: IF YOU HAVE PURCHASED A QUICK CONNECT CAPTURE PLATE (PART# 3317) AND DID NOT RECEIVE INSTRUCTIONS, THEY ARE AVAILABLE ONLINE, OR YOU CAN CONTACT PULLRITE CUSTOMER SERVICE AT (800) 443-2307.

Failure to modify the length of the brake away cable that activates the emergency braking of your trailer, may cause the cable to catch on protruding parts of the hitch. Resulting damage will not be covered by the manufacturers warranty.

There should be a minimum of 6” between the truck bed rails and the under side of the trailer for side tilt clearance. It is the customers responsibility to adjust the trailer king pin box for the appropriate amount of clearance.

NOTE: Some truck models are being manufactured with higher bed sides, making it necessary to adjust the height of your trailer's king pin box. If you don't have enough height adjustment available, PullRite produces a 3” Lift Kit that attaches to the rails of your 3100 (ask for part# 3108) or 4100, 3300 and 4400 (ask for part# 4408) SuperGlide models.

Some truck beds have contoured bed sides, making the inside bed measurement narrower. Make certain the trailer's king pin box does not contact the inside edge of the bed.

Trucks with bed liners may need a tall Mounting Post. See “NOTE” under “Drilling the Bed” for further details.

It is the installers and customers responsibility to ensure there is proper clearance between the truck and trailer. There should be a minimum of 2” of clearance as the trailer passes the cab. Call PullRite technical support with trailer width, make and year of truck and distance the king pin is from leading edge of the trailer (See “Caution” section, in the SuperGlide Owners Manual, for measuring procedure) at (800) 443-2307.

Read these instructions completely and follow them accurately. Should you have any questions, please call the factory at (800) 443-2307 prior to installation for assistance. *If you did not receive your Owners Manual, visit us online at www.pullrite.com or call the number above.*

The SuperGlide was designed for short bed pickup trucks. The hitch may function in a longer bed truck, but no mounting brackets exist to make the transfer. Some 4100 and 4400 mounting kits may transfer with modification.

Table of Contents

Caution	4
Universal Capture Plate Installation	4-6
Hitch Parts List	7
Exploded View Hitch	8
Truck Preparation & Mounting Bracket Inst.	9
Marking the Bed for Drilling	10-11
Mounting Bracket and Hardware Parts List	12

CAUTION

As a general rule, for the SuperGlide hitch to maintain proper clearance to the truck, the leading edge of the trailer (measured at the corner) should be even with the center of the king pin. (Figure 1). Most truck trailer combinations will allow 102" wide trailers if the king pin is located as described. Narrower trailers will allow the king pin to be "tucked" under the trailer over hang to some extent. Call PullRite technical support with trailer width, make and year of truck and distance the king pin is from leading edge of the trailer. 1-800-443-2307

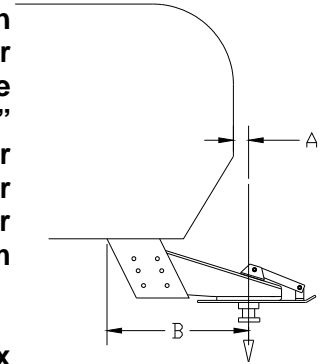

Figure 1

Using a trailer that has a long rear slope to the King Pin Box Hangar, "B" in (Figure 1), may cause damage to the trailer or truck bed during turns. Dimension "B" must be less than one half the width of the inside top edges of the bed. Please call PullRite technical support, 1-800-443-2307, if more information concerning this problem is needed.

The SuperGlide hitch is equipped with a side to side pivot feature. There should be a minimum of 6" between the truck bed rails and the under side of the trailer for side tilt clearance. It is the customers responsibility to adjust the trailer king pin box for the appropriate amount of clearance depending on the terrain being traveled (example: some State Parks are sloped and unpaved; some driveways are steeply angled). If bed covers are added, care must be taken to allow for additional clearance.

KING PIN CAPTURE PLATE INSTALLATION

The following instruction should be followed to install the king pin Capture Plate.

FOR KING PIN BOXES WITH A FLANGE: (Figure 2).

1. Place the Capture Plate {J2} over the king pin, with the guide wedge towards the rear of the trailer (wedge facing down). Align the Capture Plate {J2} square with the king pin box and clamp in place to prevent movement.
2. Mark the holes for drilling through the Capture Plate {J2} onto the king pin box flange. Use holes that are located as far from the king pin as possible.
3. Remove the Capture Plate {J2} or use it as a guide and drill ¼" holes through the flange.
4. Re-install the Adapter Plate (as in step 1).

Use the ¼" bolts provided, to secure the Capture Plate {J2} onto the king pin box flange. A **minimum of 10 bolts** must be used to fasten the plate on. For use with heavy trailers, more bolts will be needed to secure this plate. All flat head bolts should be flush or slightly below the surface of the Capture Plate so as not to score the hitch plate.

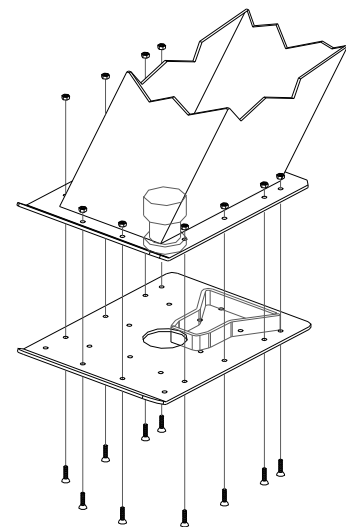

Figure 2

KING PIN CAPTURE PLATE INSTALLATION

FOR KING PIN BOXES WITHOUT FLANGES: (Figure 3)

1. Place the Capture Plate {J2} over the king pin, with the guide wedge towards the rear of the trailer (wedge facing down), and hold in place to prevent movement.
2. The Capture Plate {J2} can be secured to the king pin box sides by welding angle iron supports to the king pin box, or use the procedure in step 3. (Angle iron is not provided).
3. For the holes where you cannot reach the backside, drill holes with a #8 drill and tap with a ¼"-20 tap.
4. If the Capture Plate {J2} extends forward beyond the king pin box, then install the Knee Braces as shown in Figure 3.
5. Install the Capture Plate {J2}, using the ¼" bolts provided, to secure the Capture Plate {J2} onto the king pin box. A **minimum of 10 bolts** must be used to fasten the plate on. For use with heavy trailers, more bolts will be needed to secure this plate. **The bolts used to fasten the Knee Braces to the Capture Plate do not count as part of the number of bolts necessary to properly attach the Capture Plate to the king pin box.** All flat head bolts should be flush or slightly below the surface of the Capture Plate so as not to score the hitch plate .

NOTE: If more information is needed, please call PullRite at 1-800-443-2307.

Figure 3

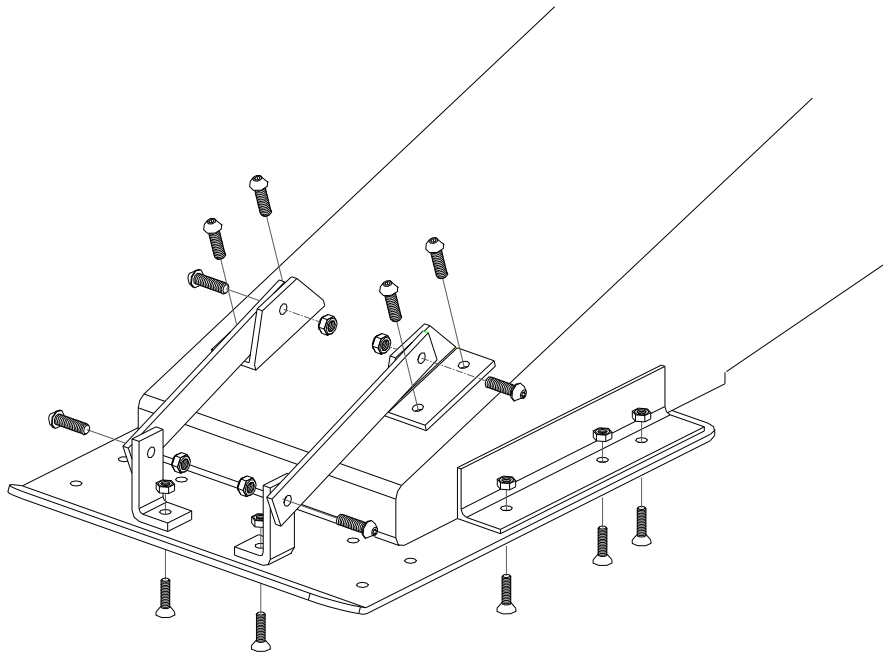

FOR KING PIN BOXES THAT ARE SHORTER FRONT TO BACK: (Figure 4)

1. Place the Capture Plate {J2} over the king pin, with the guide wedge towards the rear of the trailer (wedge facing down), and measure the distance from the front and rear of the king pin box to the respective edges of the Capture Plate {J2} (to the bend of the Capture Plate {J2} in the front). Referring to Figure 4, fashion two plates, 3/16" to 1/4" thick, that will cover the holes of the Capture Plate {J2} showing in front and rear of the king pin box.
2. While the Capture Plate is in position under the king pin box, clamp these plates to both the front and rear of the Capture Plate {J2}. Remove the Capture Plate {J2} and drill matching holes in the two support plates with a 1/4" bit using the Capture Plate {J2} as a guide.
3. Fasten the two support plates to the Capture Plate {J2} with the 1/4" Bolts {K7} and Lock Nuts {K8} provided.
4. Replace the Capture Plate {J2} on the king pin box, check for square alignment and **weld** the support plates to the king pin box.
5. Attach the Knee Braces {K2,3 & 4} to the king pin box, the Capture Plate Knee Braces {k2} may have to be welded on if the interior of the king pin box is not accessible. The bolts used to fasten the Knee Braces to the Capture Plate do not count as part of the number of bolts necessary to properly attach the Capture Plate to the king pin box.

Note: Kit # 331703 consisting of pre drilled support plates are available from PullRite but are not part of the stock Capture Plate Kit. Kit # 331703 was designed to fit the 8"x12" Lippert pin box. This method of attaching the Capture Plate {J2} should allow **10 bolts** to be used.

CAUTION: When using kit #331703 on slightly larger pin boxes, it may be necessary to trim the plates for proper fit—when installed, the provided Capture Plate adapter (3317) should be flush against the bottom of the trailer's king pin plate.

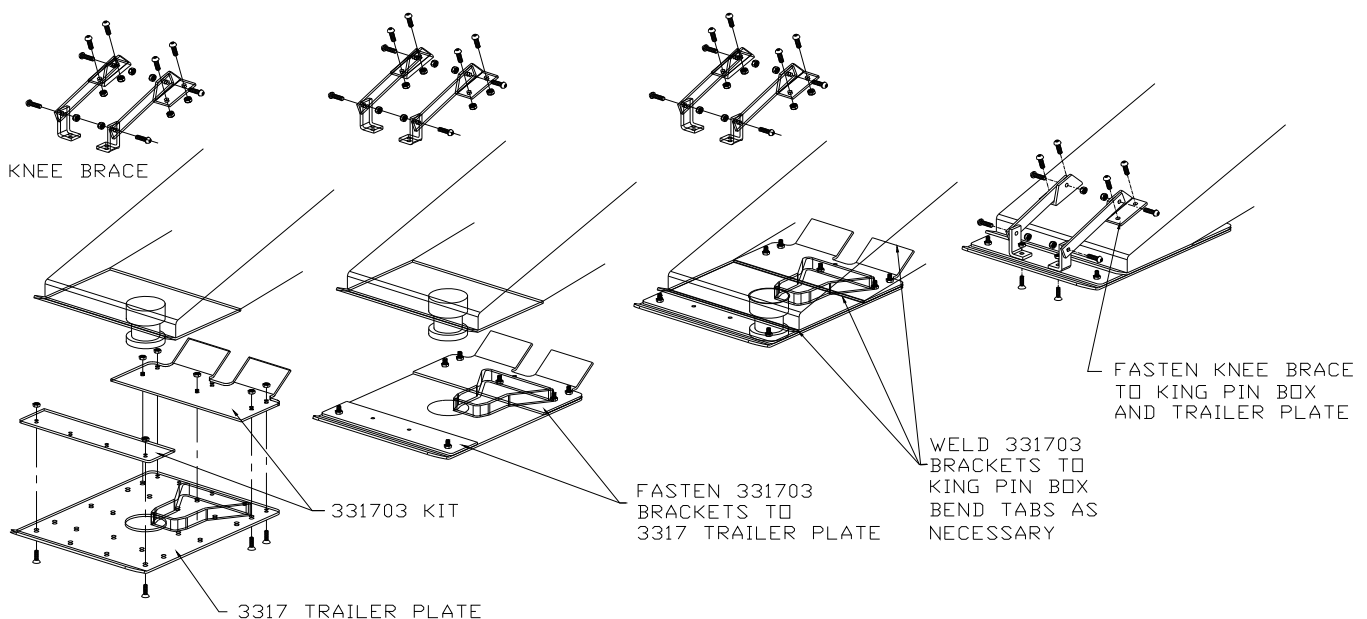

Figure 4

Parts Listing

<u>Item #</u>	<u>Assemblies / Kits</u>	<u>Number</u>	<u>Qty.</u>	<u>Material</u>
A1	5th Wheel Plate Asm.	3601		
B1	Rocker Arm Asm.	3502		
C1	Turntable Cam Arm Asm.	3603		
C2	Roller	6901	1	
C3	Lock Washer	98200124	1	3/4" Lock Washer
C4	Jam Nut	98150142	1	3/4" Nut
D1	Turntable Ways (Set)	3604		
E1	Forward Shaft Stop Asm.	3606		
E2	Nylon Stop Block	33050105	1	
E3	Bolt	98410238	1	1/4"-20 x 1 3/4" HHCS, GRD 2
E4	Flat Washer	98250130	2	1/4" Flat Washer
E5	Lock Washer	98200160	1	1/4" Lock Washer
E6	Nut	98150209	1	1/4"-20 Hex Nut
F1	Base Assembly	3305		
F2	Shaft Stop Set Screw	98010128	1	3/4"-10 x 2 1/2" HHCS
F3	Set Screw Jam Nut	98150131	1	3/4" -10 Hex Nut
H1	Hardware Kit	3610		
H2	Rocker Arm , Clevis Pin	98410111	2	1/2" x 2" Clevis Pin
H3	Clevis Pin Clip	98410127	2	#3 Cotter Pin
H4	Rocker Arm Pivot Bolt	140501	1	1" - 8 x 9 1/2" HHCS
H5	Pivot Bolt Lock Washer	98200115	1	1" Zinc Plated Split Lock Washer
H6	Pivot Bolt Hex Nut	98150120	1	1" - 8 SAE Zinc Hex Nut
H8	Rocker Arm Spring	35100001	1	16 GA Spring Steel
H9	Rocker Arm Spg Bolt	98010243	1	5/16"-18 x 3/4" Button Head Cap Screw
H10	Spring Bolt Lock Wash	98200159	1	5/16" Zinc Split Lock Washer
H11	Spring Flat Washer	98250160	1	5/16"-18 Flat Washer
H12	Way Tube Bolt	98010167	4	1/2"-13 x 1 1/2" HHCS GRD 5
H13	Way Tube Flat Washer	98250160	4	1/2" Flat Washer
H14	Way Tube Lock Washer	98200142	4	1/2" Lock Washer
H15	Way Tube Nut	98150153	4	1/2"-13 Hex Nut
J1	Universal Capture Plate Kit (sold separately)			
		3317 (*) denotes-		included in Universal Capture Plate Kit
J2	*Capture Plate	331701	1	
K1	*Capture Plate Hdw. Kit	331702	1	
K1	Capture Plate Hardware Kit	331702		
K2	Support Angle	35170002	2	3/16" x 1.5" x 1.5" Angle
K3	Support Bar	35170003	2	3/16" x 1" Flat
K4	Support "L" Bracket	35170004	2	3/16" x 1" Flat
K5	Support Bracket Bolts	98010243	8	5/16"-18 x 3/4" Button Head Cap Screw
K6	Support Bracket Nuts	98150202	8	5/16" -18 Nylock Nut
K7	Capture Plate M Bolts	98010240	10	1/4" -20 x 1 1/4" Flat Head Allen
K8	Capture Plate M Nut	98410255	10	1/4" - 20 Nylock Nut

3600 EXPLODED VIEW

Figure 5

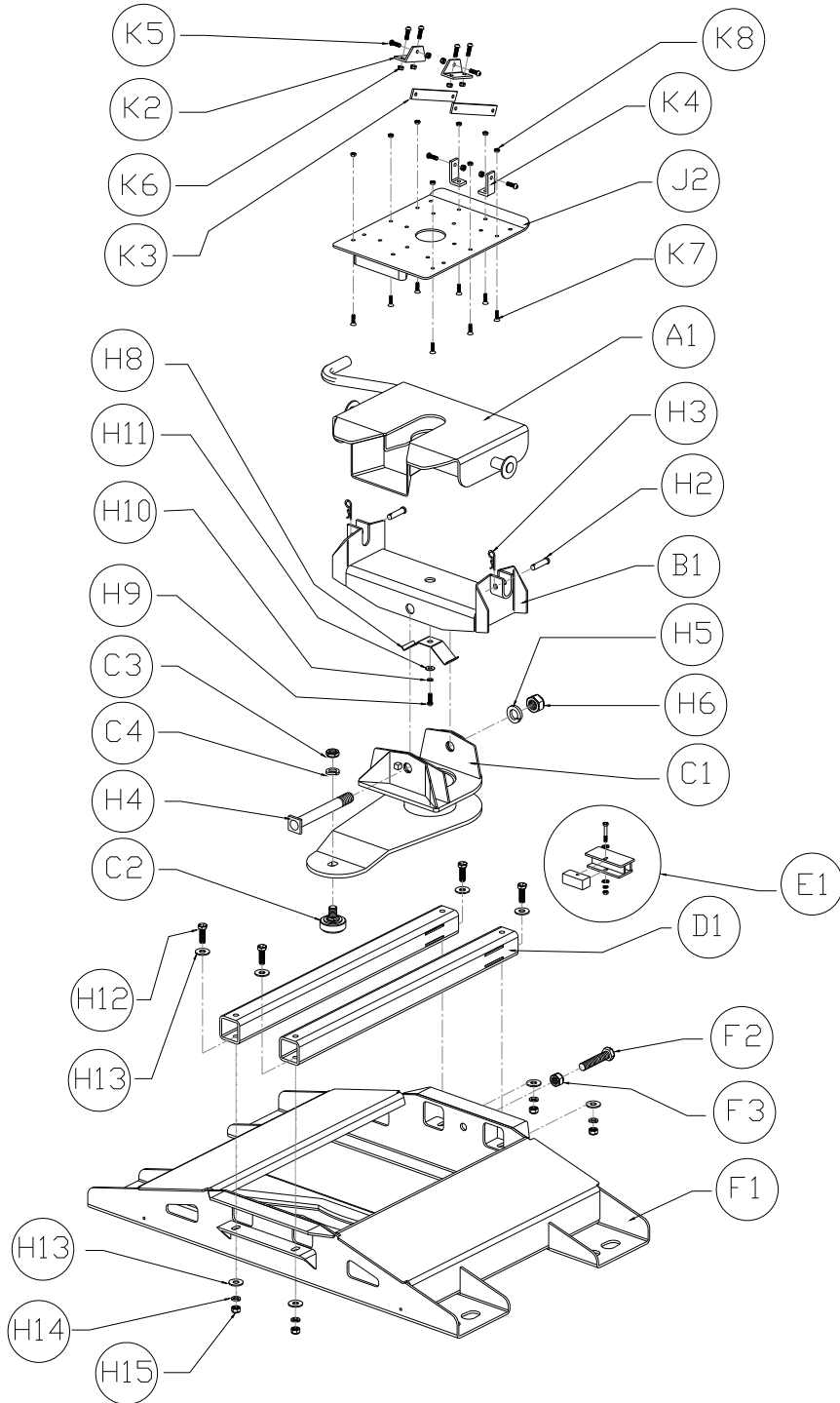
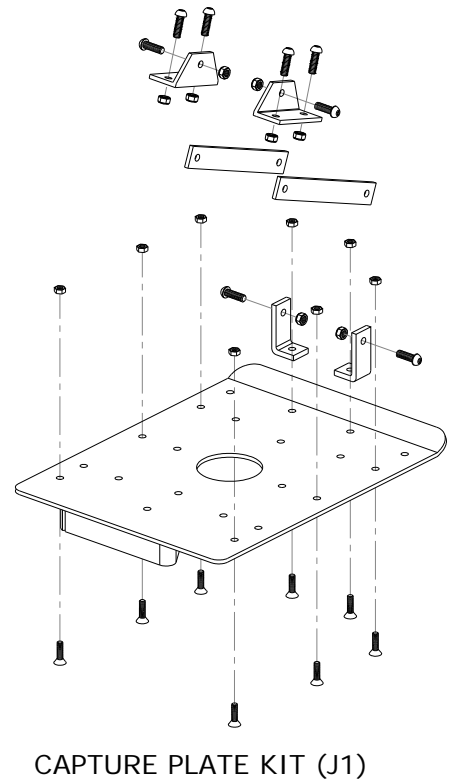

Figure 6



Mounting Bracket and Hitch Installation

Truck Preparation

1. Check part quantities using the Parts List.
2. Raise the rear of the truck.
3. Remove wheels.
4. If there are overload brackets, they must be removed and reinstalled after the mounting brackets are installed.
5. Unfasten the emergency brake cable on the driver's side of the frame.

Mounting Bracket Installation

1. Remove the driver's side front post holder.
2. Reinstall the post holder sandwiching the emergency brake cable between the back of the post holder. Fasten bolts loose enough so the post holder can be moved in and out.
3. All the post holder fasteners (D) should be loose at this point, allowing the in and out movement.
4. Using bolt hole (E) as a guide, drill the frame and install the bolt finger-tight.

Driver's Side Mounting Brackets:

1. See figure 1 and parts list . The bolt holes and appropriate bolts are listed and labeled by letters.
2. Fasteners (F) will bolt to existing holes on the frame. Finger tighten only.
3. Install fastener (A) using a frame clip. See enlarged drawing in figure 2.
4. Install fastener (B) to existing frame hole. Tighten by hand.

Passengers Side Mounting Brackets:

1. Make certain the post holder fasteners are loosened then install bolts using the directions for the driver's side.

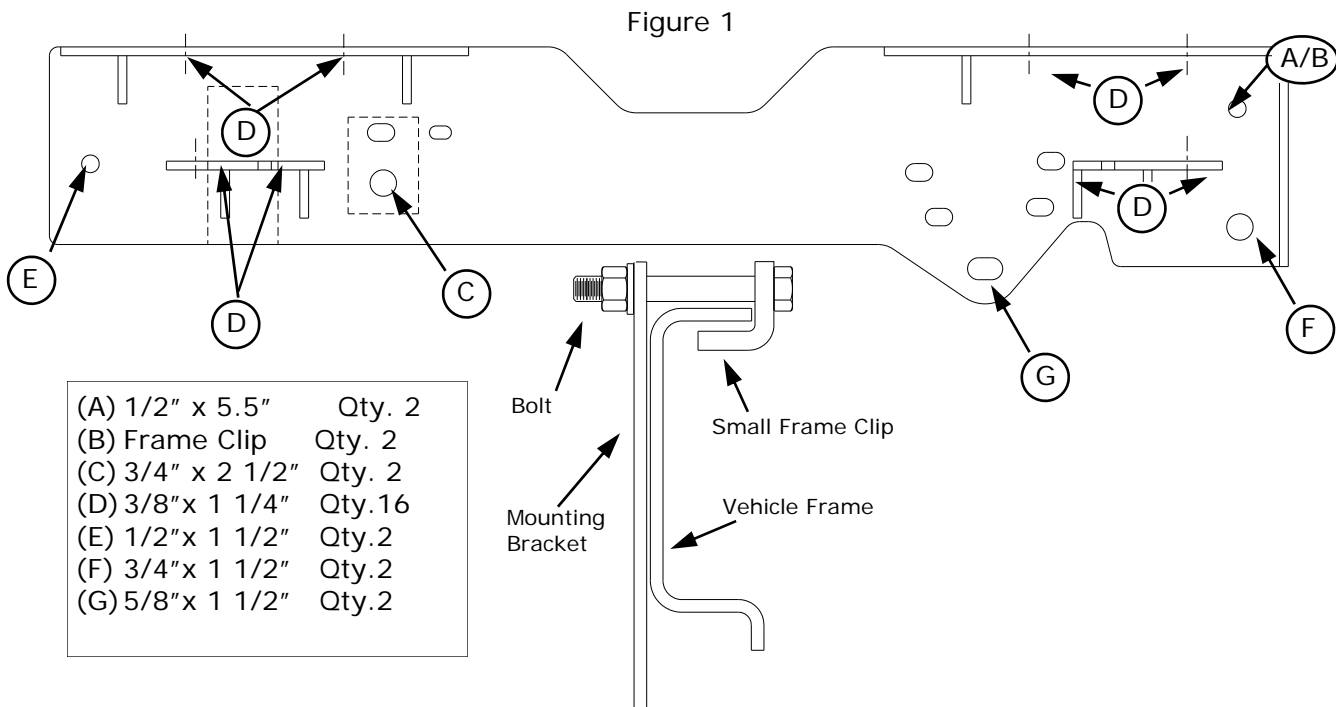

Figure 2

Marking the Bed for Drilling

1. See figure 3. Measure and mark from the back of the bed forward $46\text{-}7/8"$. Do this at any point on both sides of the bed.
2. Draw a line across the bed from mark to mark.
3. Measure $24"$ from the line towards the rear of the bed and mark on both sides.
4. Draw a line from mark to mark
5. Find the centerline of the bed. Draw a line down the middle of the bed from front to rear. See Figure 3.
6. Measure out from the centerline $21"$ on each side at the front and the rear of the bed and make a mark. Draw a line on each side (parallel to the centerline), from mark to mark. See
7. Drill a $1/16"$ pilot hole where the lines cross, beginning with the driver's side front mark. The bit should come down through the post holder in the mounting bracket, centered front to rear. Don't worry about centering from side to side since the post holder can move in and out.
8. If the pilot hole is off center (front to rear) to the post holder, adjust the drill placement and re-drill.

NOTE: If you have to re-drill in order to be centered, remember to adjust the other three holes accordingly.

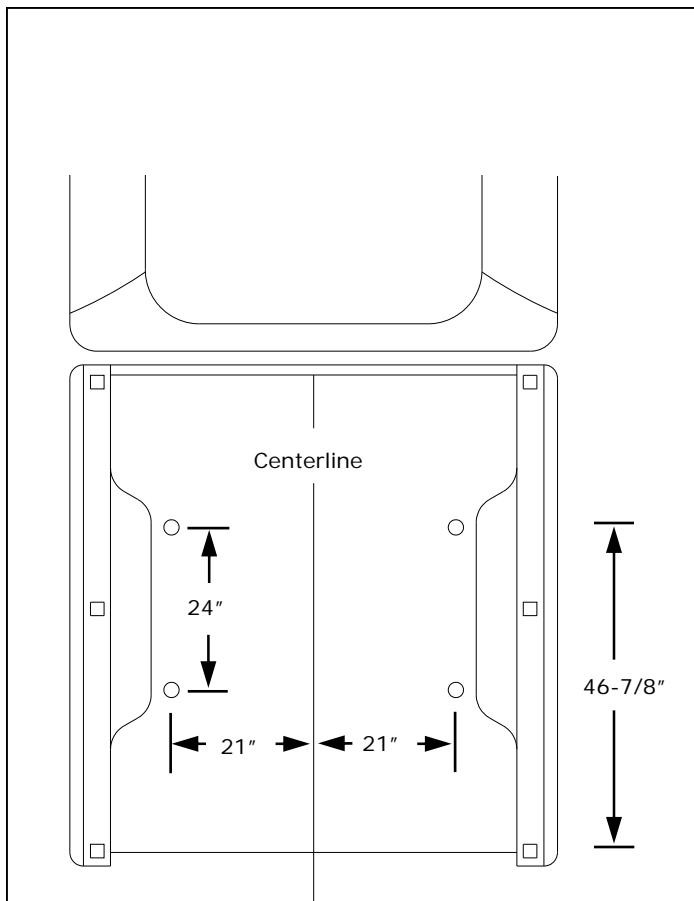

Figure 3

Layout (Template Method)

1. Lay the Template in the truck bed, centering it from side to side, $21\text{ }7/8"$ from the end of the truck bed. The template is semetrical so there is no front or rear.
2. Mark the 4 **outside** holes as shown in Figure 4 below.

The template does not come with the hitch. Ask your distributor salesman for information about receiving a free set of steel installation templates.

INSTALLATION TIP: The template has a tendency to move when placed on the slick paint of new truck beds, and it may be helpful to place a small piece of NON-SKID matting, such as "SCOOT-GARD"™, to help keep the template from moving.



Figure 4

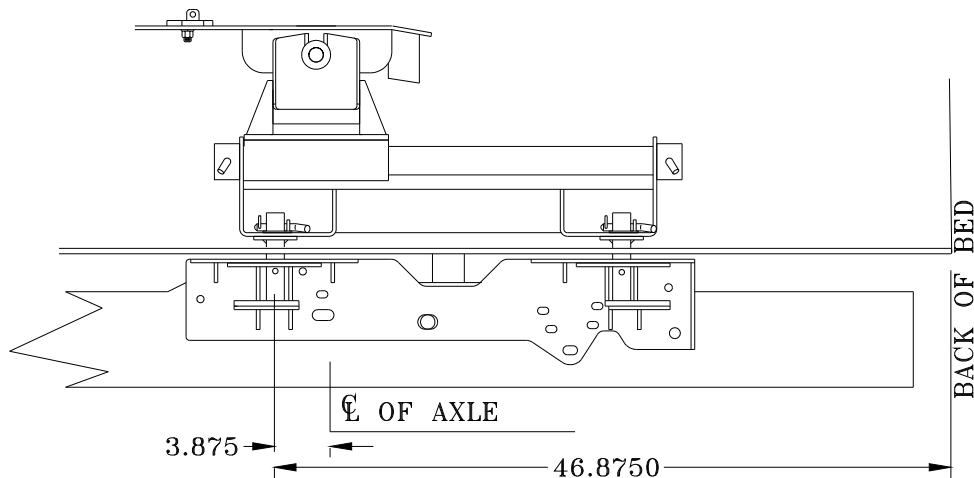

9. After locating the center front to rear, adjust the post holders in and out using the drill bit through the hole as a visual aid to find the center.
10. Finger tighten fasteners (D) to hold the post holder in the center position. Repeat steps 1-9 for the other three hole locations.
11. Using a 2-1/8" hole saw, centered over the 1/16" pilot hole, cut the bed for the mounting posts.

NOTE: You may want to remove the post holders when you drill so the saw does not catch on the holder.

12. Debur inside the holes, use a paint stick to touch up the edges.
13. Install the mounting posts through the bed into the post holders. Rotate the posts a quarter turn.

NOTE: The post is tall enough to clear most bed mats, bed liners may require taller posts to seat into the post holders properly.

14. Position the hitch on the post and install keepers and pins.

NOTE: You may have to slide the hitch base to the rear of the vehicle to seat the keepers in place. See page 10 for details on installing the hitch.

15. Tighten the mounting brackets to the frame and post holders to the brackets using the following torque values for each bolt:

- 3/8" Bolt — 31 ft. lbs.
- 1/2" Bolt — 75 ft. lbs.
- 5/8" Bolt — 151 ft. lbs.
- 3/4" Bolt — 266 ft. lbs.

16. Reinstall overload brackets. Reinstall emergency brake cable in holes provided.

NOTE: You may need to cut an inch or so off the overload spring to keep it from hitting the mounting brackets.

Mounting Bracket and Hardware Parts List

<u>Reference</u>	<u>Description</u>	<u>Quantity</u>
1	Mounting Brackets	2
2	Mounting Brackets Post Holders	4
3	Small Frame Clips	8
4	Mounting Posts	4
5	Keepers	4
6	Keeper Pins and Clips	4
F	3/4" x 1-1/2" Hex Head Bolts w/ nuts & lock washers	2
D	3/8" x 1-1/4" Carriage Bolts w/ nuts, flat washers, & lock washers	16
A	1/2" x 5.5" Hex Head Bolts w/ nuts & lock washers	2
E	1/2" x 1-1/2" Hex Head Bolts w/ nuts & lock washers	2
B	5/8" x 1-1/2" Hex Head Bolts w/ nuts & lock washers	2
C	3/4" x 2-1/2" Hex Head Bolts w/ nuts & lock washers	2

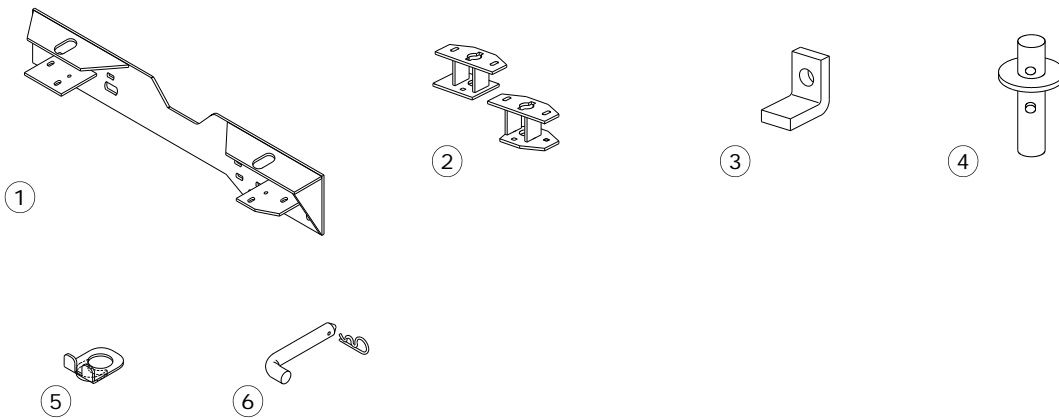



MANUFACTURED BY:
PULLIAM ENTERPRISES, INC.
13790 East Jefferson Blvd.
Mishawaka, IN 46545
(574) 259-1520 • (800) 443-2307
info@pullrite.com • www.pullrite.com