



SuperRail Installation Instructions

(1987-98 Ford Super Duty w/ 6' Bed—Bracket #3511)



IMPORTANT!

1. The SuperGlide's Way tubes are coated with SlipPlate® at the factory to provide lubrication for ONE TRIP ONLY. You will need to continue using the graphite-based lubricant SlipPlate® or a medium duty grease on the top and inward facing sides of the way tubes. Failure to properly lubricate (*see Operator Instructions for complete lubrication instructions*) the Way Tubes WILL cause galling between the metal of the Way Tubes and the Cam Arm Assembly. When movement of the Cam Assembly is stopped due to galling, damage to the hitch structure WILL take place, resulting in truck/trailer damage. Damages incurred due to lack of proper lubrication are NOT manufacturer defects and WILL NOT be considered a warranty issue The trailer's king pin box must be equipped with a Capture Plate (Universal or Quick Connect) to allow the hitch to function properly.
2. The trailer king-pin must be kept even with /or forward of the foremost point of the trailer. See "Caution" and "figure 1" on pg. 3.
3. Trucks with bed liners may need a tall Mounting Post. See "NOTE" under item 13 of "Drilling the Bed" on pg. 10 for detail.
4. Read these instructions completely and follow them accurately. Should you have any questions, please call the factory at (800) 443-2307 for installation assistance.

Table of Contents

Caution	3
King Pin Capture Plate Installation	3-5
Hitch Parts List	6
Exploded View Hitch	7
Mounting Bracket Kit Parts List	8
Truck Preparation & Mounting Bracket Inst.	9
Drilling The Bed	9-11
Warranty	12

CAUTION

As a general rule, for the SuperGlide hitch to maintain proper clearance to the truck, the leading edge of the trailer (measured at the corner) should be even with the center of the king pin. (Figure 1). Most truck trailer combinations will allow 102" wide trailers if the king pin is located as described. Narrower trailers will allow the king pin to be "tucked" under the trailer over hang to some extent. Call PullRite technical support with trailer width, make and year of truck and distance the king pin is from leading edge of the trailer. 1-800-443-2307

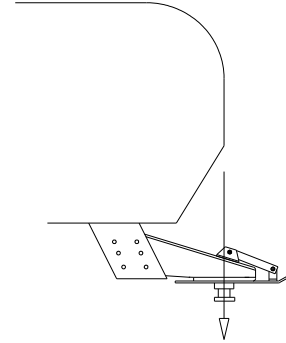

Figure 1

Using a trailer that has a long rear slope to the King Pin Box Hangar, "B" in (Figure 1), may cause damage to the trailer or truck bed during turns. Dimension "B" must be less than one half the width of the inside top edges of the bed. Please call PullRite technical support, 1-800-443-2307, if more information concerning this problem is needed.

The SuperGlide hitch is equipped with a side to side pivot feature. There should be a minimum of 6" between the truck bed rails and the under side of the trailer for side tilt clearance. It is the customers responsibility to adjust the trailer king pin box for the appropriate amount of clearance depending on the terrain being traveled (example: some State Parks are sloped and unpaved; some driveways are steeply angled). If bed covers are added, care must be taken to allow for additional clearance.

KING PIN CAPTURE PLATE INSTALLATION

The following instruction should be followed to install the king pin Trailer Plate.

FOR KING PIN BOXES WITH A FLANGE: (Figure 2).

1. Place the Capture Plate {J2} over the king pin, with the guide wedge towards the rear of the trailer (wedge facing down). Align the Capture Plate {J2} square with the king pin box and clamp in place to prevent movement.
2. Mark the holes for drilling through the Capture Plate {J2} onto the king pin box flange. Use holes that are located as far from the king pin as possible.
3. Remove the Capture Plate {J2} or use it as a guide and drill ¼ " holes through the flange.
4. Re-install the Adapter Plate (as in step 1).
Use the ¼" bolts provided, to secure the Capture Plate {J2} onto the king pin box flange. A **minimum of 10 bolts** must be used to fasten the plate on. For use with heavy trailers, more bolts will be needed to secure this plate. All flat head bolts should be flush or slightly below the surface of the trailer plate so as not to score the hitch plate.

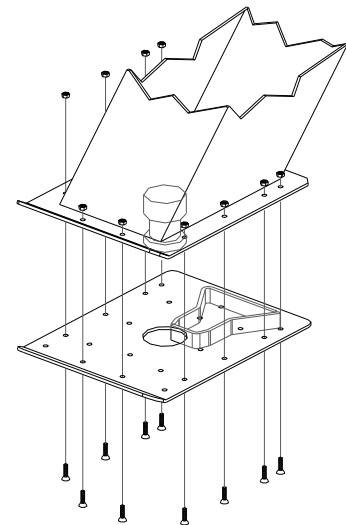

Figure 2

KING PIN CAPTURE PLATE INSTALLATION (cont.)

FOR KING PIN BOXES WITHOUT FLANGES: (Figure 3)

1. Place the Capture Plate {J2} over the king pin, with the guide wedge towards the rear of the trailer (wedge facing down), and hold in place to prevent movement.
2. The Capture Plate {J2} can be secured to the king pin box sides by welding angle iron supports to the king pin box, or use the procedure in step 3. (Angle iron is not provided).
3. For the holes where you cannot reach the backside, drill holes with a #8 drill and tap with a ¼"-20 tap.
4. If the Capture Plate {J2} extends forward beyond the king pin box, then install the Knee Braces as shown in Figure 3.
5. Install the Capture Plate {J2}, using the ¼" bolts provided, to secure the Capture Plate {J2} onto the king pin box. A **minimum of 10 bolts** must be used to fasten the plate on. For use with heavy trailers, more bolts will be needed to secure this plate. **The bolts used to fasten the Knee Braces to the Trailer Plate do not count as part of the number of bolts necessary to properly attach the Trailer Plate to the king pin box.** All flat head bolts should be flush or slightly below the surface of the trailer plate so as not to score the hitch plate .

NOTE: If more information is needed, please call PullRite at 1-800-443-2307.

Figure 3

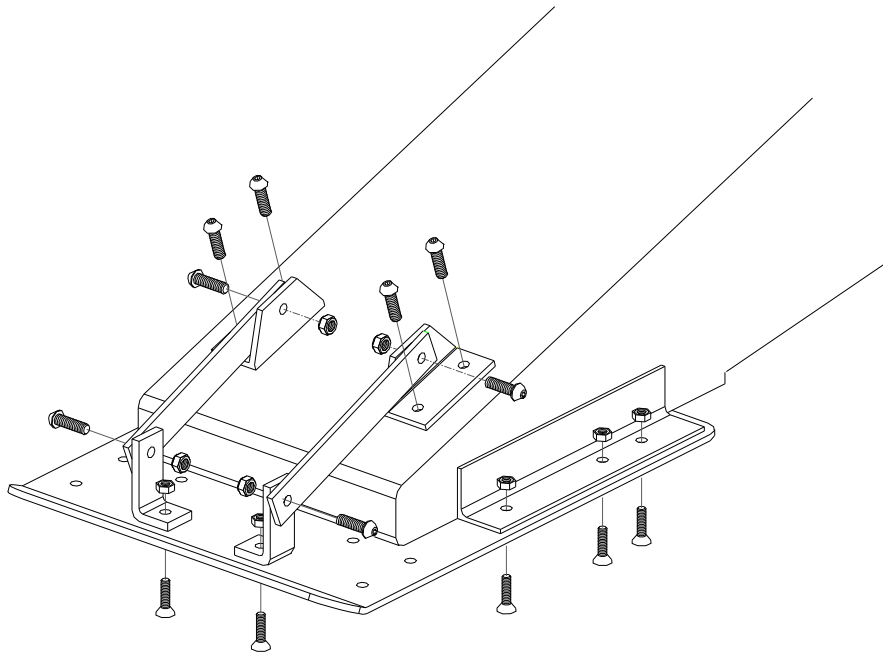

FOR KING PIN BOXES THAT ARE WIDER AND SHORTER: (Figure 4)

1. Place the Capture Plate {J2} over the king pin, with the guide wedge towards the rear of the trailer (wedge facing down), and measure the distance from the front and rear of the king pin box to the respective edges of the Capture Plate {J2} (to the bend of the Capture Plate {J2} in the front). Referring to Figure 4, fashion two plates, 3/16" to 1/4" thick, that will cover the holes of the Capture Plate {J2} showing in front and rear of the king pin box.
2. While the Capture Plate is in position under the king pin box, clamp these plates to both the front and rear of the Capture Plate {J2}. Remove the Capture Plate {J2} and drill matching holes in the two support plates with a 1/4" bit using the Capture Plate {J2} as a guide.
3. Fasten the two support plates to the Capture Plate {J2} with the 1/4" Bolts {K7} and Lock Nuts {K8} provided.
4. Replace the Capture Plate {J2} on the king pin box, check for square alignment and **weld** the support plates to the king pin box.
5. Attach the Knee Braces {K2,3 & 4} to the king pin box, the Capture Plate Knee Braces {k2} may have to be welded on if the interior of the king pin box is not accessible. The bolts used to fasten the Knee Braces to the Capture Plate do not count as part of the number of bolts necessary to properly attach the Trailer Plate to the king pin box.

Note: Kit # 331703 consisting of pre drilled support plates are available from PullRite but are not part of the stock Capture Plate Kit. Kit # 331703 was designed to fit the 8"x12" Lippert pin box. This method of attaching the Capture Plate {J2} should allow **10 bolts** to be used.

CAUTION: When using kit #331703 on slightly larger pin boxes, it may be necessary to trim the plates for proper fit—when installed, the provided trailer plate adapter (3317) should be flush against the bottom of the trailer's king pin plate.

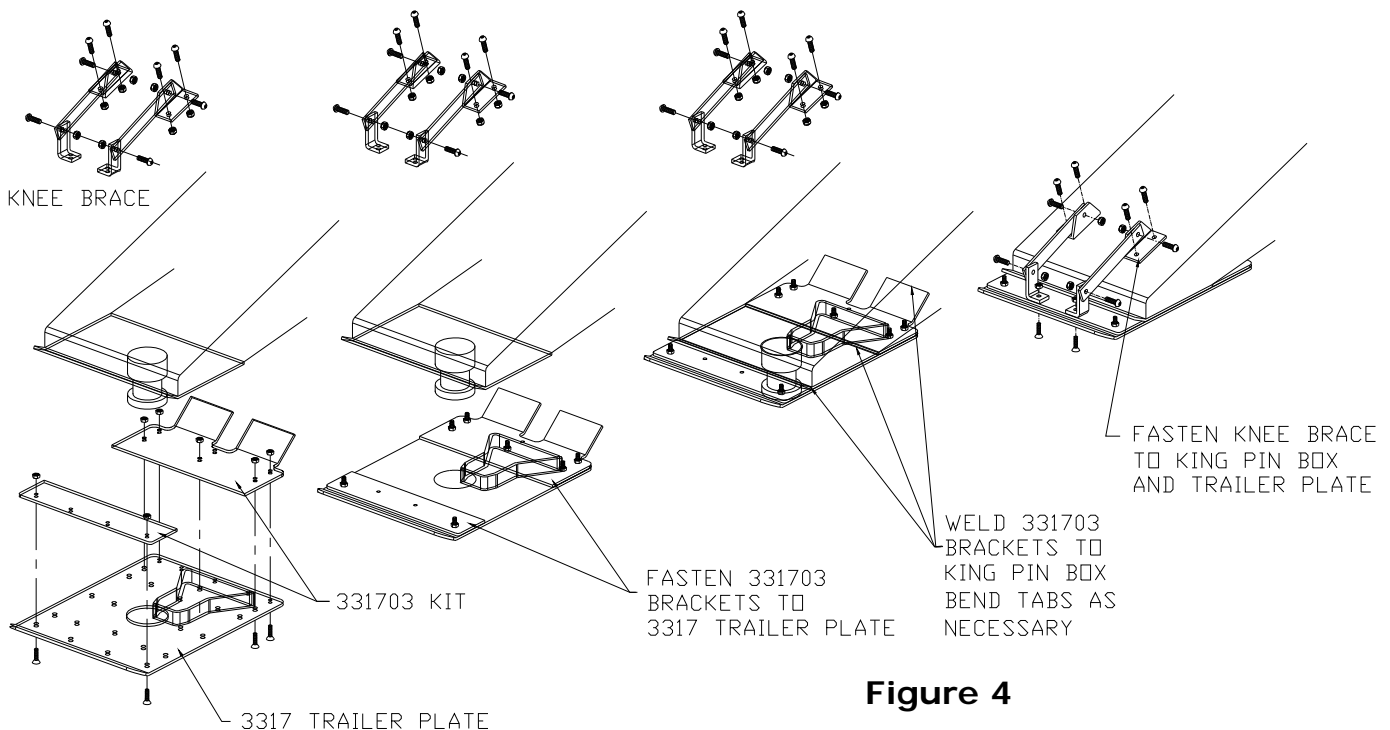
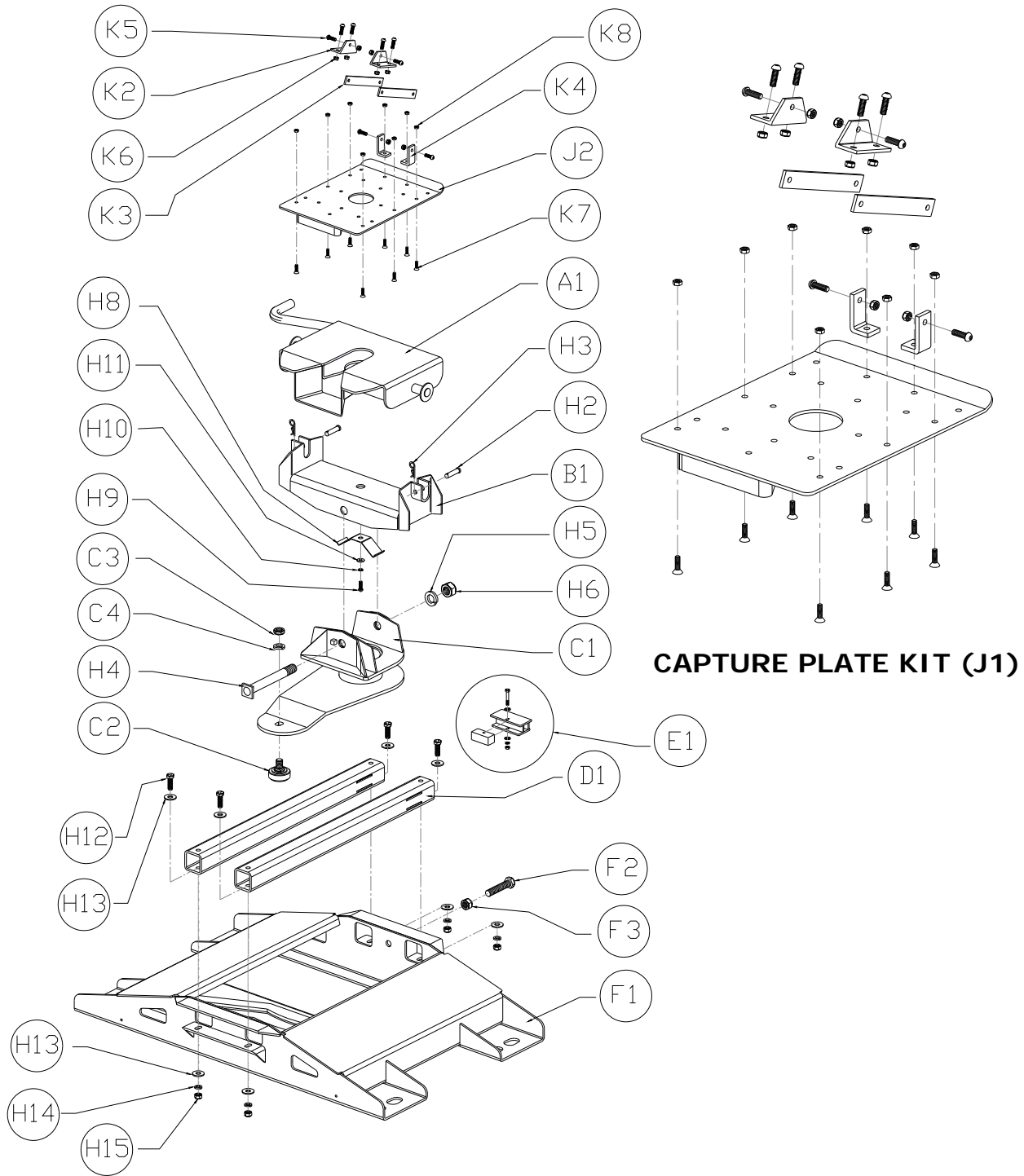

Figure 4

Parts Listing

<u>Item #</u>	<u>Assemblies / Kits</u>	<u>Number</u>	<u>Qty.</u>	<u>Material</u>
A1	5th Wheel Plate Asm.	3601		
B1	Rocker Arm Asm.	3502		
C1	Turntable Cam Arm Asm.	3603		
C2	Roller	6901	1	
C3	Lock Washer	98200124	1	3/4" Lock Washer
C4	Jam Nut	98150142	1	3/4" Nut
D1	Turntable Ways (Set)	3604		
E1	Forward Shaft Stop Asm.	3606		
E2	Nylon Stop Block	33050105	1	
E3	Bolt	98410238	1	1/4"-20 x 1 3/4" HHCS, GRD 2
E4	Flat Washer	98250130	2	1/4" Flat Washer
E5	Lock Washer	98200160	1	1/4" Lock Washer
E6	Nut	98150209	1	1/4"-20 Hex Nut
F1	Base Assembly	3305		
F2	Shaft Stop Set Screw	98010128	1	3/4"-10 x 2 1/2" HHCS
F3	Set Screw Jam Nut	98150131	1	3/4" -10 Hex Nut
H1	Hardware Kit	3610		
H2	Rocker Arm , Clevis Pin	98410111	2	1/2" x 2" Clevis Pin
H3	Clevis Pin Clip	98410127	2	#3 Cotter Pin
H4	Rocker Arm Pivot Bolt	140501	1	1" – 8 x 9 1/2" HHCS
H5	Pivot Bolt Lock Washer	98200115	1	1" Zinc Plated Split Lock Washer
H6	Pivot Bolt Hex Nut	98150120	1	1" – 8 SAE Zinc Hex Nut
H8	Rocker Arm Spring	35100001	1	16 GA Spring Steel
H9	Rocker Arm Spg Bolt	98010243	1	5/16"-18 x 3/4" Button Head Cap Screw
H10	Spring Bolt Lock Wash	98200159	1	5/16" Zinc Split Lock Washer
H11	Spring Flat Washer	98250160	1	5/16"-18 Flat Washer
H12	Way Tube Bolt	98010167	4	1/2"-13 x 1 1/2" HHCS GRD 5
H13	Way Tube Flat Washer	98250160	4	1/2" Flat Washer
H14	Way Tube Lock Washer	98200142	4	1/2" Lock Washer
H15	Way Tube Nut	98150153	4	1/2"-13 Hex Nut
J1	Universal Capture Plate Kit	3317 (sold separately) (* denotes– included in Kit)		
J2	*Capture Plate	331701	1	
K1	*Capture Plate Hd. Kit	331702	1	
K1	Capture Plate Hardware Kit	331702		
K2	Support Angle	35170002	2	3/16" x 1.5" x 1.5" Angle
K3	Support Bar	35170003	2	3/16" x 1" Flat
K4	Support "L" Bracket	35170004	2	3/16" x 1" Flat
K5	Support Brkt Bolts	98010243	8	5/16" -18 x 3/4" Button Head Cap Screw
6	Support Bracket Nuts	98150202	8	5/16" –18 Nylock Nut
K7	Capture Plate M Bolts	98010240	10	1/4" –20 x 1 1/4" Flat Head Allen
K8	Capture Plate M Nut	98410255	10	1/4" – 20 Nylock Nut

PARTS LIST ILLUSTRATION



3511 MOUNTING BRACKET KIT

Description	Part No.	Qty. Used	Material
(1) FRAME BRACKET ASSEMBLY	351101	1 SET	DRIVER/PASSENGER FRAME BRACKETS
(2) MOUNTING POST TUBE ASSEMBLY	351102	4	
(5) MOUNTING POST ASSEMBLY	351103	4	
97 HD FORD MOUNTING HARDWARE KIT	351104	1	

Description	Part No.	Qty. Used	Material
3/8" -16 x 1 1/4" CARRIAGE BOLT	98050137	8	3/8"-16 x 1 1/4" CARRIAGE BOLT GRD 5
3/8" SPLIT LOCK WASHER	98250160	8	3/8" SPLIT LOCK WASHER
3/8" FLAT WASHER	98250175	8	3/8" FLAT WASHER
3/8"-16 HEX NUT	98150211	8	3/8-16 HEX NUT

351104 HARDWARE KIT

Description	Part No.	Qty. Used	Material
(3) LARGE FRAME CLIP	35110401	2	
(4) SMALL FRAME CLIP	35110402	8	
1/2" x 2 1/2" FRAME BOLT	98010179	2	1/2"-13 x 2 1/2" HHCS GRD 5
1/2"x 4" FRAME BOLT	98010191	4	1/2"-13 x 4" HHCS GRD 5
1/2" x 4 1/2" FRAME BOLT	98010195	4	1/2"- 13 x 4 1/2" HHCS GRD 5
1/2" SPLIT LOCK WASHER	98200142	10	1/2" SPLIT LOCK WASHER
1/2" HEX NUT	98150153	10	1/2"-13 HEX NUT
5/8"x 1 1/2" LOCATOR BOLT	98010231	2	5/8"-11 x 1 1/2" HHCS GRD 5
5/8" SPLIT LOCK WASHER	98200133	2	5/8" SPLIT LOCK WASHER
5/8" HEX NUT	98150175	2	5/8" - 11 HEX NUT
(6) MOUNTING POST KEEPER	351001	4	10 GA
(7) MOUNTING POST KEEPER PIN	35100003	4	1/2"RD
(7) #3 HITCH PIN CLIP	98410127	4	

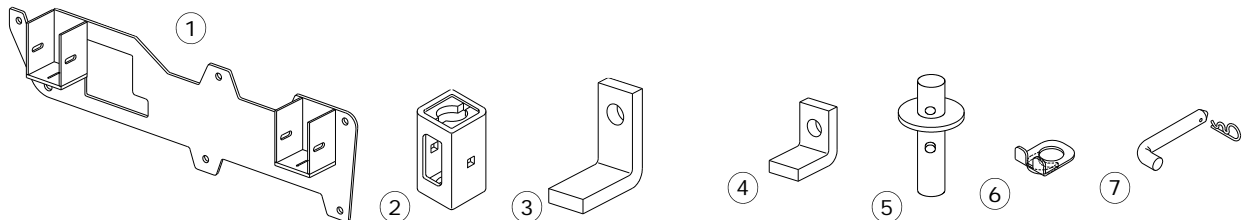

Mounting Bracket Installation

Truck Preparation

1. Check part quantities using the Parts List on Page 6 and 8.
2. Raise the rear of the truck.
3. Remove wheels.
4. Remove the exhaust hanger from the passenger's side of the frame.

Mounting Bracket Installation

1. Loosen all 3/8" bolts holding post holders so they will move in and out.
2. See figure 1. The bolt holes and appropriate bolts are listed and labeled by letters.

Driver's Side Mounting Brackets:

1. Position the bracket on the frame using the locator hole (D) seen in figure 1. The large square hole installs around the overload bracket.
2. Install fastener (A) using a frame clip and tighten by hand. See enlarged drawing in Figure 2.
3. Install fasteners (B) using a small frame clips and 1/2" x 4-1/2" bolts. Tighten by hand.

Passengers Side Mounting Brackets:

1. Make certain the post holder fasteners are loosened then install bolts using the directions for the driver's side.

Marking the Bed for Drilling

1. See figure 3. Measure and mark from the back of the bed forward 47-5/32". Do this at any point on both sides of the bed.
2. Draw a line across the bed from mark to mark.
3. Measure 24" from the line towards the rear of the bed and mark on both sides.
4. Draw a line from mark to mark
5. Find the centerline of the bed. Draw a line down the middle of the bed from front to rear. See Figure 3.
6. Measure out from the centerline 21" on each side at the front and the rear of the bed and make a mark. Draw a line on each side (parallel to the centerline), from mark to mark. See figure 3.
7. Drill a 1/16" pilot hole where the lines cross, beginning with the driver's side front mark. The bit should come down through the post holder in the mounting bracket, centered front to rear. Don't worry about centering from side to side since the post holder can move in and out.
8. If the pilot hole is off center (front to rear) to the post holder, adjust the drill placement and re-drill.

NOTE: If you have to re-drill in order to be centered, remember to adjust the other three holes accordingly.

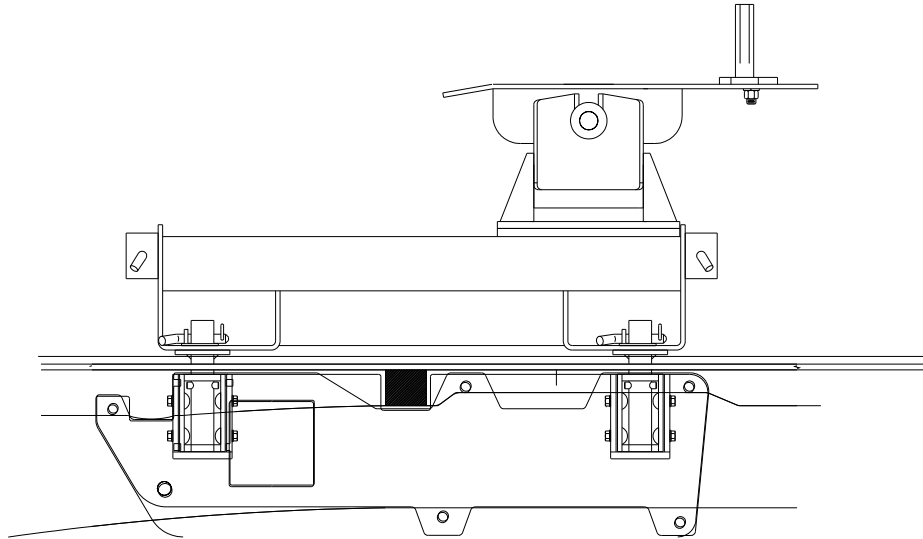

9. After locating the center front to rear, adjust the post holders in and out using the drill bit through the hole as a visual aid to find the center.
10. Finger tighten fasteners (E) to hold the post holder in the center position. Repeat steps 1-9 for the other three hole locations.
11. Using a 2-1/8" hole saw, centered over the 1/16" pilot hole, cut the bed for the mounting posts.

NOTE: You may want to remove the post holders when you drill so the saw does not catch on the holder.

12. Deburr inside the holes, use a paint stick to touch up the edges.
13. Install the mounting posts through the bed into the post holders. Rotate the posts a quarter turn.

NOTE: The post is tall enough to clear most bed mats, bed liners may require taller posts to seat into the post holders properly.

14. Position the hitch on the post and install keepers and pins.

NOTE: You may have to slide the hitch base to the rear of the vehicle to seat the keepers in place.

15. Now you can tighten all mounting bracket bolts.
 - (a) Tighten brackets to frame.
 - (b) Tighten post holders to brackets.
16. Please follow these torque values for each bolt:

3/8" Bolt — 31 ft. lbs.
1/2" Bolt — 75 ft. lbs.
5/8" Bolt — 151 ft. lbs.

17. Drill holes on the passenger side to reinstall the exhaust bracket.

NOTE: You may need to cut an inch or so off the overload spring to keep it from hitting the mounting brackets.

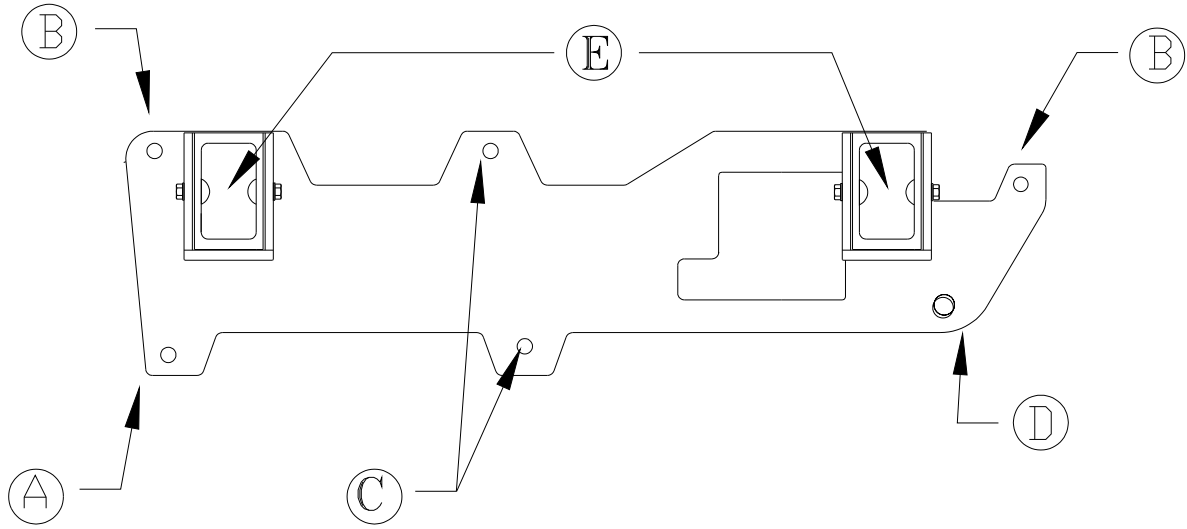

Figure 1

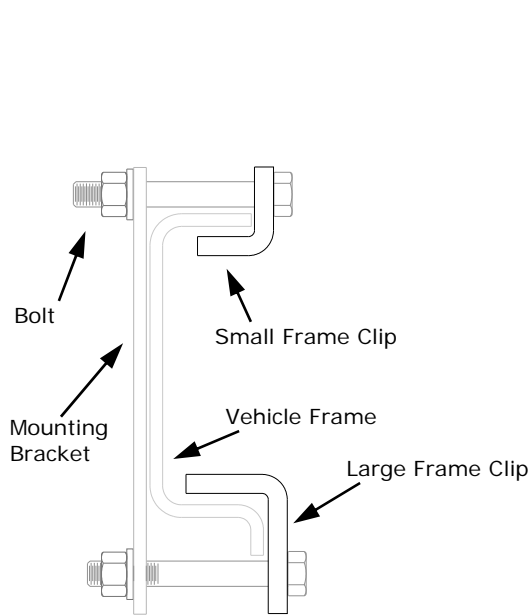

Figure 2

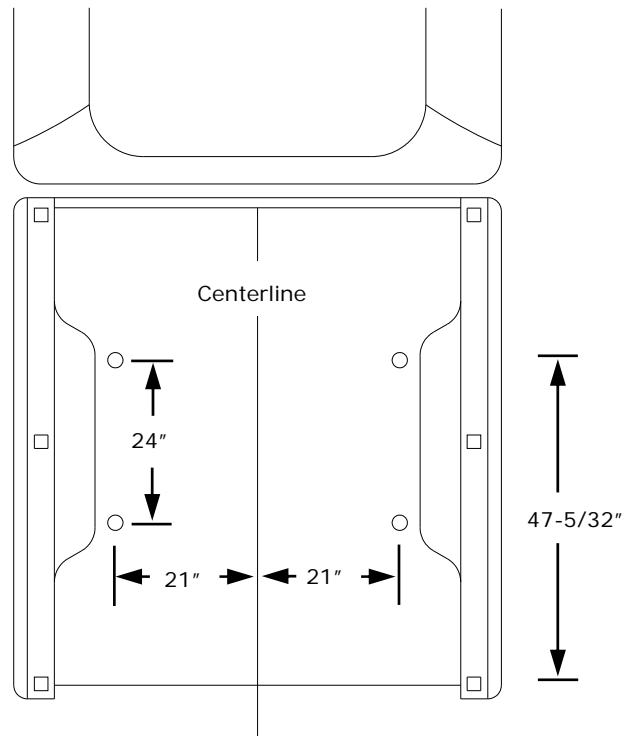

Figure 3

FIVE YEAR LIMITED WARRANTY

PULLIAM ENTERPRISES, INC. hereinafter referred to as "**PULLIAM**", warrants to the first retail owner only, this PullRite towing system to be free from defects in materials and workmanship for a period of five (5) years after the installation on purchaser's vehicle.

To validate this warranty, the first retail owner must mail the provided warranty card to **PULLIAM** within ten (10) days after installation of said towing system on his vehicle.

The owner is responsible for all normal and preventive maintenance described in the Owner's Instructions.

If any defect occurs which the owner believes is covered by this warranty within said five (5) year period, the owner shall contact **PULLIAM** immediately, either in writing or by telephone call, Attention Customer Service Department.

The owner will be instructed to return the vehicle at his expense either to an authorized PullRite dealer or to **PULLIAM** to repair or replace any parts necessary to correct defects in material or workmanship.

Repair or replacement shall be at the sole option of **PULLIAM** and shall be completed by or on behalf of **PULLIAM** free of charge for materials and labor.

This warranty gives you specific legal rights, and you may also have other right's which vary from state to state.

THIS WARRANTY SPECIFICALLY EXCLUDES EACH OF THE FOLLOWING:

1. Defects in the product resulting from misuse, neglect, accident, loading beyond the vehicle's capacity, failure to comply with instructions contained in the Owner's Instruction or unauthorized repairs, replacements, alterations or modifications. "Unauthorized repair, replacements, alterations" are those made without **PULLIAM'S** prior knowledge and consent.
2. Any incidental or consequential damage including, but not limited to, loss of use of the vehicle, towing charges, vehicle rental, loss of time, inconvenience, travel, gasoline, lodging and telephone expenses, loss of revenue and damages on account of personal injury and property damage. (Some states do not allow the exclusion or limitation of incidental or consequential damages, so these limitations may not apply to you).
3. Repairs or replacements of defects in any PullRite towing system, or part thereof, installed on any vehicle which has been rented, leased or used for any commercial purpose.
4. Any representation, warranty of undertaking made by any dealer or third party beyond the scope of the warranty herein expressed.
5. Any problem resulting in normal deterioration due to wear or exposure.

TO THE EXTENT PERMITTED BY LAW, IMPLIED WARRANTIES OF MERCHANTABILITY AND FITNESS FOR A PARTICULAR PURPOSE ARE LIMITED IN DURATION TO ONE YEAR FROM THE DATE OF INSTALLATION ON THE FIRST OWNER'S VEHICLE. (SOME STATES, HOWEVER, DO NOT ALLOW LIMITATIONS AS TO DURATION OF IMPLIED WARRANTY, SO THOSE LIMITATIONS MAY NOT APPLY TO YOU)

PULLRITE TRAILER TOWING SYSTEMS

MANUFACTURED BY:

PULLIAM ENTERPRISES, INC.
13790 East Jefferson Blvd.
Mishawaka, IN 46545
(574) 259-1520 or (800) 443-2307
info@pullrite.com • www.pullrite.com

