



SuperRail Mounting Kit

#0841, #0842, #0843 & #0844



#1200 SuperGlide
(16K)

Gross Trailer Weight (Maximum) 16,000 lbs.
Vertical Load Weight (Max. Pin Weight) 4,000 lbs.



#0800 SuperGlide
(20.5K)

Gross Trailer Weight (Maximum) 20,500 lbs.
Vertical Load Weight (Max. Pin Weight) 5,125 lbs.

Installation Instructions

SPECIFICATIONS

- #0841 fits 1999-2011 Ford F250 & F350
- #0842 fits 1995-2002 Ford (except '02-'04 1500)
- #0843 fits 2001-2010 Chevy 2500 & 3500 HD
- #0844 fits 2003-2010 Dodge 2500 & 3500 (except 2WD 3500)

Table of Contents

	<u>PAGE #</u>
#0800 & #1200 - Parts List	3
Hitch Assembly	4
Installation - Marking & Drilling Bed	5-7
#0841 - Ford Custom Installation Instructions	8-12
#0842 - Dodge Custom Installation Instructions	13-16
#0843 - Chevy Custom Installation Instructions	17-19
#0844 - Dodge Custom Installation Instructions	20-24

20,500 PARTS LIST

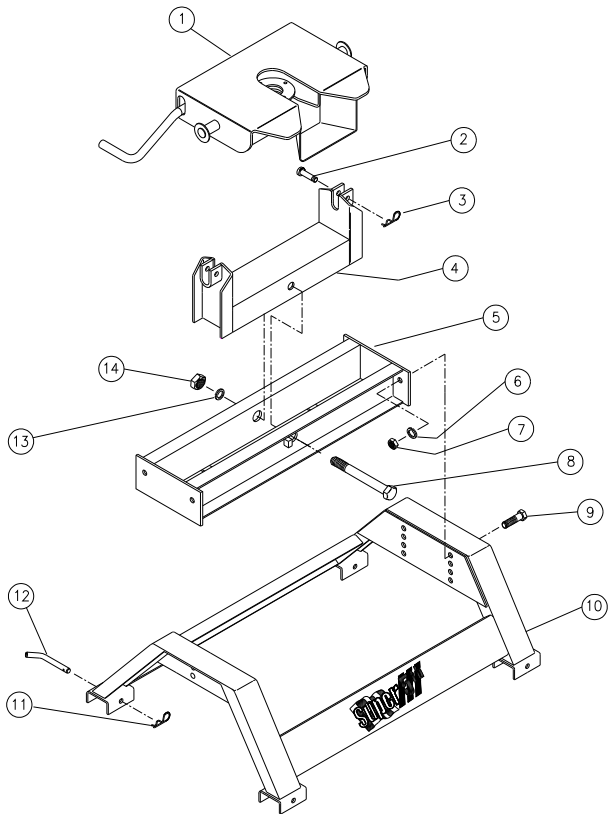

Figure 1

Ref.	Part #	Part Name
1	3601	Plate
2	98410111	Clevis Pin
3	98410127	Clevis Pin Clip
4	0802	Rocker Arm
5	0803	Crossmember
6	98200142	1/2" Lock Washer
7	98150153	1/2"-13 Hex Nut
8	98010147	Rocker Arm Pivot Bolt
9	98010167	1/2"-13 x 1 1/2" HHCS
10	0804	Base
11	98410127	Clevis Pin Clip
12	08060001	Base Rail Hinge Pin
13	98200124	3/4" Split Lock Washer
14	98150131	3/4"-10 Hex Nut

Table 1

16,000 PARTS LIST

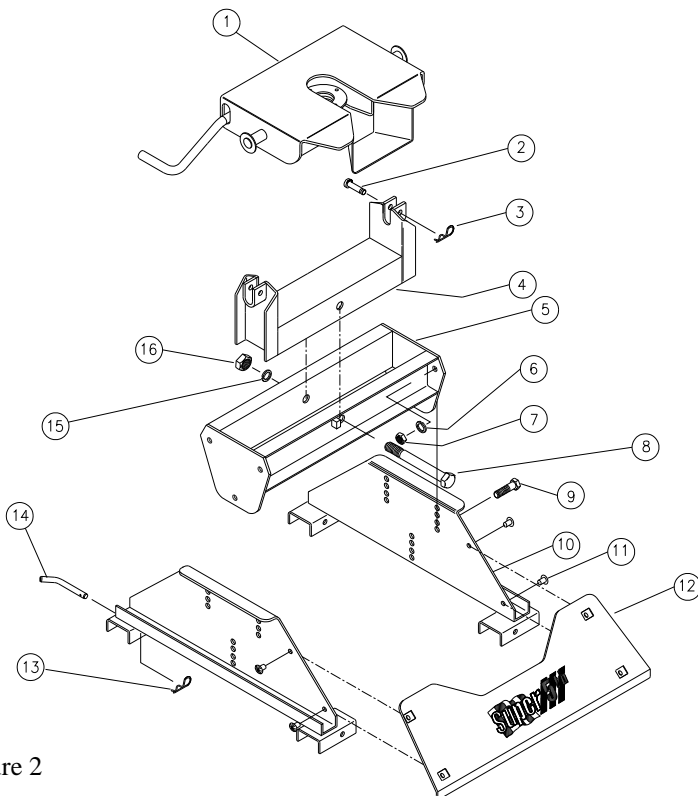

Figure 2

Ref.	Part #	Part Name
1	3601	Plate
2	98410111	Clevis Pin
3	98410127	Clevis Pin Clip
4	0802	Rocker Arm
5	1202	Crossmember
6	98200142	1/2" Lock Washer
7	98150153	1/2"-13 Hex Nut
8	98010147	Rocker Arm Pivot Bolt
9	98010167	1/2"-13 x 1 1/2" HHCS
10	1203	Base Sides (set)
11	98410560	Plastic Barbed Fastener
12	120302	Cover Assembly
13	98410127	Clevis Pin Clip
14	08060001	Base Rail Hinge Pin
15	98200124	3/4" Split Lock Washer
16	98150131	3/4"-10 Hex Nut

Table 2

Hitch Assembly

Hitch Assembly for 20,500#:

If the hitch type to be installed is a 20,500# (Part #0800), there is no assembly required except to attach the Base Rails to the base feet of the hitch Base using the four 1/2" Base Rail Pins and four #3 Pin Clips (See exploded drawing on page 3).

This hitch has four height settings and should be adjusted according to the directions found in the Operators Instructions found in the same box as the hitch. Be sure to torque all four 1/2" x 1 1/2" Bolts to 75 foot pounds after adjusting height.

Hitch Assembly for 16,000#:

If the hitch type to be installed is a 16,000# (Part #1200), it will be necessary to assemble the hitch first. Refer to page 3, the exploded view of this hitch and the parts list below the drawing then follow these steps:

1. Attach the Base Sides to the Base Rail Assembly using the four 1/2" Base Rail Pins and four #3 Pin Clips.
2. Remove the 3/4" x 7" Pivot Bolt from the Rocker Arm and Crossmember.
3. The Rocker Arm is shipped upside down in the Crossmember for better packaging and will need to be removed and reinstalled right side up in the Crossmember as shown in the exploded view drawing on page 3. Tighten the 3/4" x 7" Pivot Bolt only enough to flatten the 3/4" Lock Washer or enough so that the Rocker Arm will rotate stiffly. Lubricate the 3/4" Pivot Bolt with heavy grease before installing.
4. Fasten the Crossmember and Base Sides together using six each of the 1/2"-13 x 1 1/2" Bolts, 1/2" Lock Washers and 1/2"-13 Hex Nuts, tighten bolts to 75 foot pounds. This hitch has four height settings and should be adjusted according to the directions found in the Operators Instructions found in the same box as the hitch.
5. Fasten the Fifth Wheel Plate in the Rocker Arm using two each of the 1/2" Clevis Pins and #3 Pin Clips after installing the Release Handle and Main Spring as shown below. Be sure to install the Main Spring so that the end with the swivel hook is inserted **into** the open end of the Release Handle as shown below.

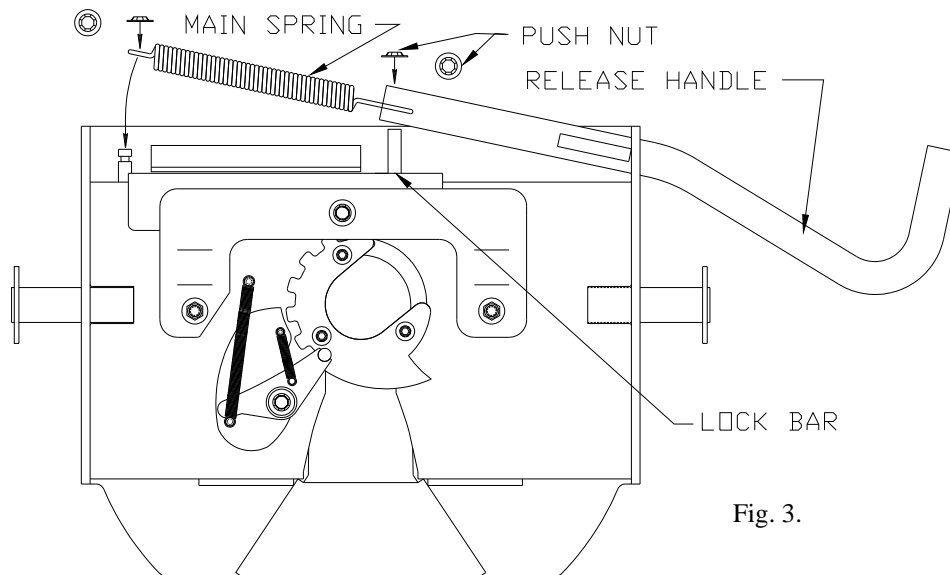

Fig. 3.

General Installation Instructions

1. NOTE: Refer to the Specific Vehicle's Figures and Reference information for all references made herein. The location of the Specific Vehicle can be found by referring to the Table of Contents.

Truck Preparation

1. Check part quantities using the **Parts List** for the specific vehicle type.
2. Block vehicle wheels. Some vehicles may require you to raise the rear of the truck in order to make it easier to drill for installing the Mounting Brackets on the truck frame.
3. You may wish to remove the wheels, to give yourself greater working room.
4. At this point, the bed should be laid out and marked for drilling using either the LAYOUT METHOD or the TEMPLATE METHOD.

Marking Bed for Drilling (layout method)

1. For layout using the Template method, see *Layout (Template Method)* on next page.
2. See **Truck Bed Layout Dimensions** table **pg. 7** for the dimension values for items **A - D** located in the 'LAYOUT METHOD' illustration. Measure and mark from the back of the bed forward the values for **A** and **B**. Do this at any point on both sides of the bed.
3. Draw a line across the bed from mark to mark.
4. Find the centerline of the bed. Draw a line down the middle of the bed from front to rear. See **Figure 5 on pg. 7**. Center the measurement of **C** across the centerline at the front most line you made in step 2, and mark the measurement on each side (parallel to the centerline). Center the measurement of **D** for the rear most line made in step 2, and again mark the measurement on each side (parallel to the centerline). This will locate the 4 drill holes.
5. Go to your truck's **SPECIFIC LISTING** (listed in the Index on pg.2) and perform the steps listed in **PART I**. The truck **Specific Listings** begin after **page 7** of these instructions.

Drilling the Bed

1. After you have removed the Mounting Brackets, use a **1 3/4"** hole saw, centered over the **1/16"** pilot hole, cut the bed for the mounting posts.
2. De-bur inside the holes, then use a paint stick to touch up the edges.
3. Re-install the Mounting Brackets and secure those that have no existing mounting holes in a temporary fashion, using 'C' clamps. Those that have holes, secure by lightly attaching with bolts (tighten sufficiently to where the Mounting Brackets lay flat against the truck frame).
4. Install the Mounting Posts through the bed into the Mounting Bracket Post Holders. Rotate the Posts a quarter turn. (**See the illustrations in the truck Specific Listings**).

NOTE: *The Mounting Post should be tall enough to clear most bed mats. Vehicles using bed liners may require taller Mounting Posts to seat into the Post Holders properly. A Tall Mounting Post (1" taller) is available under part # 330705. Four posts are required for installation.*

5. Remove the Base Rails from the shipping carton, leaving the Base Rail Extensions loose to allow lateral movement as you place the Rail assembly over the Mounting Posts. See drawing on next page.
6. Install the Base Rails in the bed of the truck, and center the Base Rails between the Base Rail Mounting Posts. Finger tighten the Base Rail mounting Bolts.
7. Set the 5th Wheel Hitch on the Base Rails, and align the Hitch Assembly with the Base Rail mounting holes, using a drift pin punch to aid your alignment. Install the Mounting Pins from the inside. Then install the Pin Clips, to secure the Hitch assembly to the Base Rails. See drawing on next page.
8. Center the Hitch assembly within the truck bed, from side to side. You might need to use a rubber mallet to get the unit to move while centering. Once the unit is centered, tighten the Base Rail Extension Bolts to 31 ft. lbs..
9. The 5th Wheel Hitch, and the Base Rails, must be removed to verify that the Mounting Post can be inserted and removed freely, without binding. A slight adjustment might be required to obtain unrestricted access.

10. Reinstall the Mounting Posts, the Base Rails, and the 5th Wheel Hitch assembly.
11. Complete the final steps needed to install the Mounting Brackets to the truck frame. Go to the truck **Specific Listings, Part II** at this time.
12. Due to slight inconsistency in manufacturing processes, it is recommended that you mark the Base Rails in such a manner that you will be able to re-install them into the same relative position as you have them presently installed.

Layout (Template Method)

A Template set containing all available Templates can be ordered, P/N 0840000, from your distributor. Templates do not come with the installation kit.

1. Lay the Template in the truck bed, centering it from side to side, and parallel to the end of the truck bed, using the dimension **X** listed in **Truck bed layout dimension** table on pg. 7.
2. Mark the 4 holes, while making sure the template does not move.
3. Go to the truck **SPECIFIC LISTING** and begin with the steps listed in **PART I**.

Torque Table

- 3/8" Bolt — 31 ft. lbs.
- 1/2" Bolt — 75 ft. lbs.
- 5/8" Bolt — 151 ft. lbs.
- 3/4" Bolt — 266 ft. lbs.

Fig. 4

SUPER RAIL BASE RAIL ASSEMBLY KIT PART NUMBER 0840

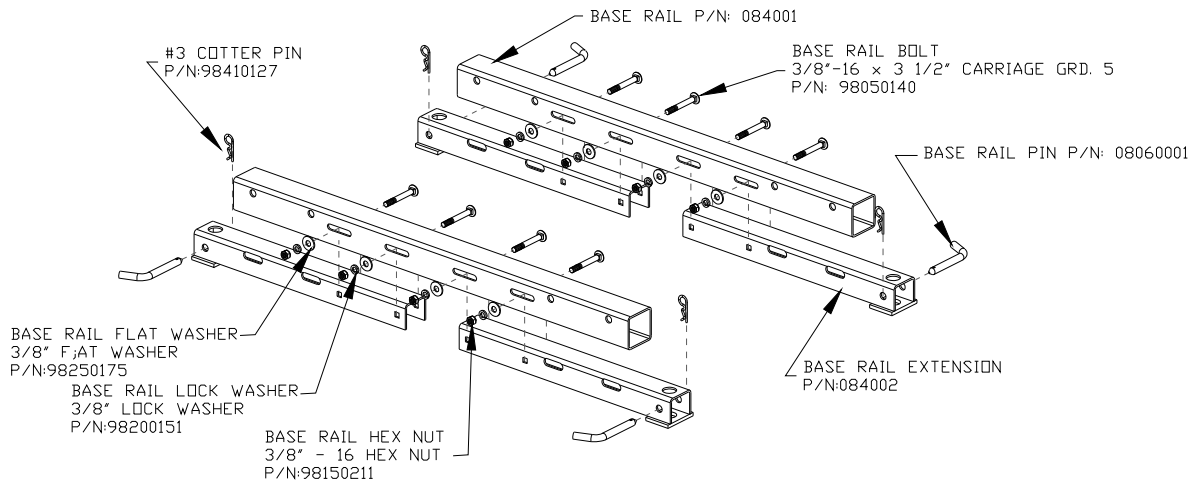

SUPER RAIL, BASE RAIL HARDWARE KIT PART NUMBER (if ordered seperately) IS 084003

Base Rail parts identification

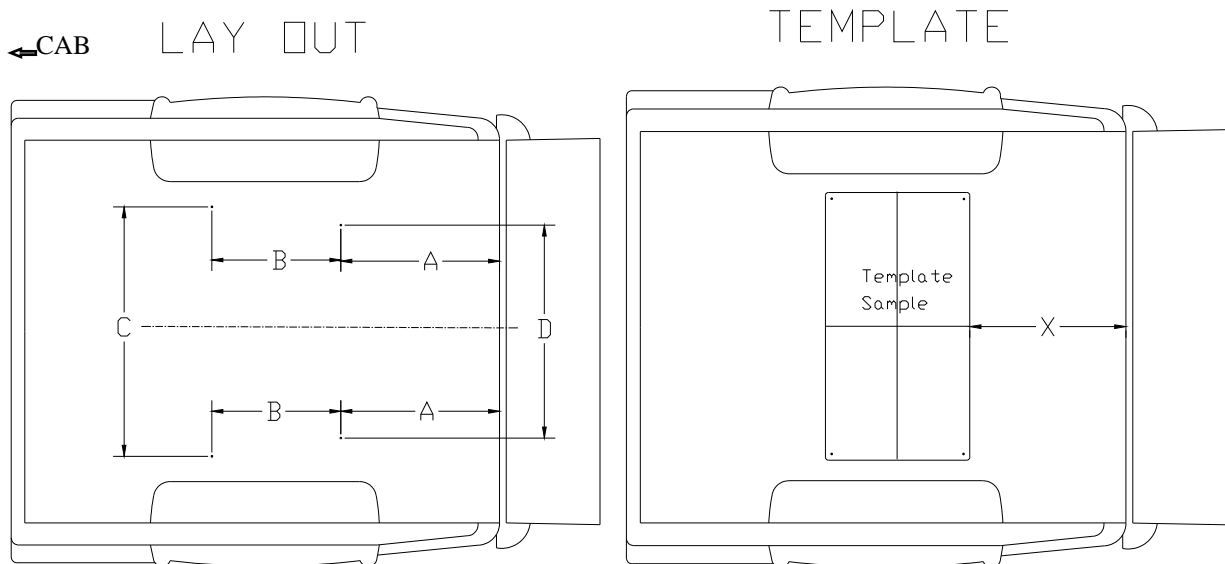

Figure 5

NOTES: The TEMPLATE should be orientated as shown in Figure 5 above after checking dimensions "C" and "D" in the table below.

INSTALLATION TIP: The template has a tendency to move when placed on the slick paint of new truck beds, and it may be helpful to place a small piece of NON-SKID matting, such as "SCOOT-GARD"™, to help keep the template from moving.

Truck Bed Layout Dimensions

Vehicle Type	Bed Length	"A"	"B"	"C"	"C" / 2	"D"	"D" / 2	Template Mode "X"	Template Part #	Distance Ahead of Axle
Chevy 1999-2010 HD 1999-2010 LD 0843	6 ft.	26 5/8"	24"	43 13/32"	21 23/32"	40"	20"	25 5/8"	085300	1/4"
	8 ft.	31 15/32"	24"	43 13/32"	21 23/32"	40"	20"	30 15/32"		
1995-2002 (except 02 1/2 ton) Dodge 0842	6 ft.	28 5/16"	24"	40 7/8"	20 7/16"	40 7/8"	20 7/16"	27 15/16"	085200	1/2"
	8 ft.	32 1/8"	24"	40 7/8"	20 7/16"	40 7/8"	20 7/16"	31 1/8"		
1999-2011 Ford SD 0841	6 ft.	31 5/32"	24"	41"	20 1/2"	41"	20 1/2"	30 5/32"	085100	1/2"
	8 ft.	31 5/32"	24"	41"	20 1/2"	41"	20 1/2"	30 5/32"		
2003-2010 Dodge, 3/4 2x4 & 4x4 & 1 Ton 4x4, 0844	6 ft.	29 11/16"	24"	42 7/16"	21 7/32"	41 13/32"	20 23/32"	28 11/16"	085400	1 3/8"
	8 ft.	31 9/16"	24"	42 7/16"	21 7/32"	41 13/32"	20 23/32"	30 9/16"		

FORD SD 1999 to 2008

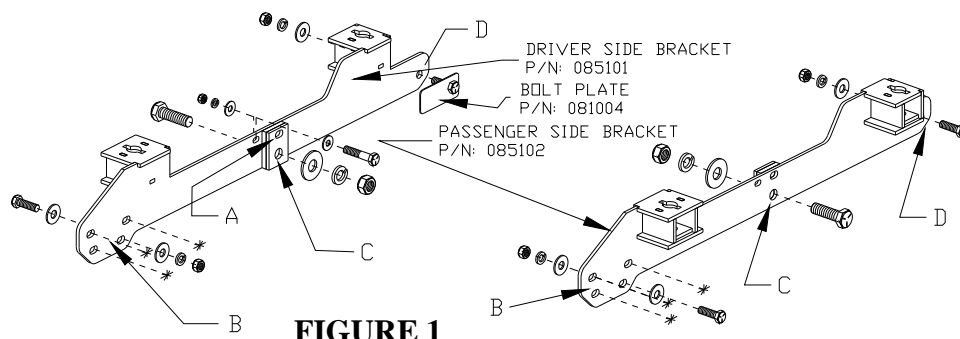

FIGURE 1

Hardware

A. 3/8" x 2"
Qty.= 1

C. 3/4" x 2 1/2"
Qty.=2

D, B. 1/2" x 1 1/2"
Qty.=9

Bolt Plate = 1

PART I Truck Preparation

1. Unfasten the emergency brake cable bolt (A) on the driver's side of the frame. (See drawing **Ford 1**). (B) is the overload spring bracket, if equipped, and must be removed at this time.

Mounting Bracket Installation.

1. Place the driver side Mounting Bracket against the truck frame, aligning the hole C, and the hole directly above hole C. (See **Ford 1**, as your guide for placement of the Mounting Bracket). Be sure to place the Mounting Bracket behind the emergency cable.
2. Temporarily attach the Mounting Bracket to the frame, using the 3/4" x 2 1/2" bolt in hole C, and the 3/8" x 2" bolt into the hole directly above C (**Figure 1** above). If the truck is equipped with overload springs, use one of the bolts that you removed when taking the overload bracket off, and place the bolt into a hole B. If the truck is NOT equipped with overload springs, use a 1/2" x 1 1/2" bolt provided (**Figure 1** above). (Some Mounting Brackets may have a slight warp to them due to the metal characteristics during the welding process. If the bracket has a warp, you will need to draw the bracket tight against the frame using either the bolts or by adding a clamp to assist in drawing the bracket against the frame.) Tighten sufficiently to hold the Mounting bracket tight against the frame.
3. Install the Mounting Bracket on the passenger side repeating steps 1-3, except there will not be the emergency brake cable to have to contend with.
4. **Figure Ford 2** illustrates the drilling of the truck bed, using a 1/16" drill.
5. Drill the first 1/16" hole in the truck bed over the rear Post Hole on the driver side Mounting bracket, where you made the mark during Truck Bed Layout. The bit should come down through the Post Holder of the Mounting Bracket, centered front to rear and side to side.
6. If the first pilot hole is off center (front to rear) to the post holder, adjust the drill placement and re-drill.

NOTE: If you have to re-drill in order to be centered, remember to adjust the other three holes accordingly.

7. Drill the remaining three pilot holes, again checking to be sure the hole is in the center of the Post Holder.
8. Remove the Mounting Bracket, and return to Drilling the Bed on pages 5 & 6 .

Ford 1

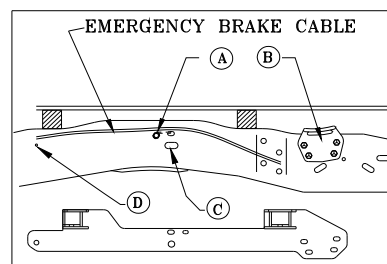

NOTE: Hole "D" does not exist on the 6' truck frame.

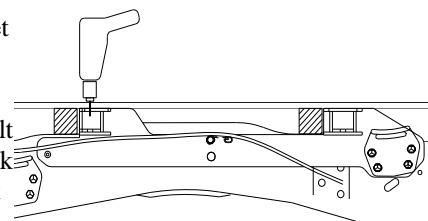

Ford 2

FORD SD continued

PART II ***Mounting Bracket installation continued.***

1. Attach the brake cable to the Mounting bracket using the 3/8" x 2" bolt through hole **A** (directly above hole **C** on the driver side). (See **Figure 1**).
2. Install bolts **B** (**Figure 1**), or use the bolts that were removed with the overload spring bracket into the **B** indicated holes, and tighten. (It may be necessary to drill these holes out to 1/2" to accept the 1/2" bolts).
3. Install the 3/4" bolt **C** shown in **figure 1**.
4. Drill hole **D** to 1/2", and fasten on the driver side with the Bolt Plate shown in **Figure 1**, and on the passenger side with 1/2" x 1 1/2" bolt **D**.
5. Torque all bolts per the table on pg. 6.

FORD SD continued

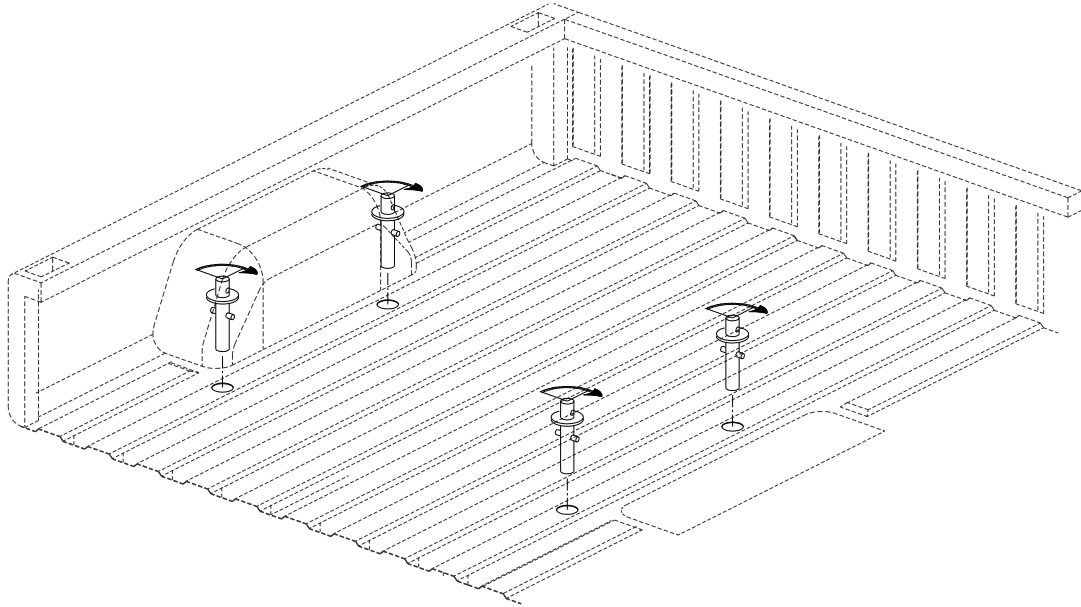

Ford Mounting Posts illustration

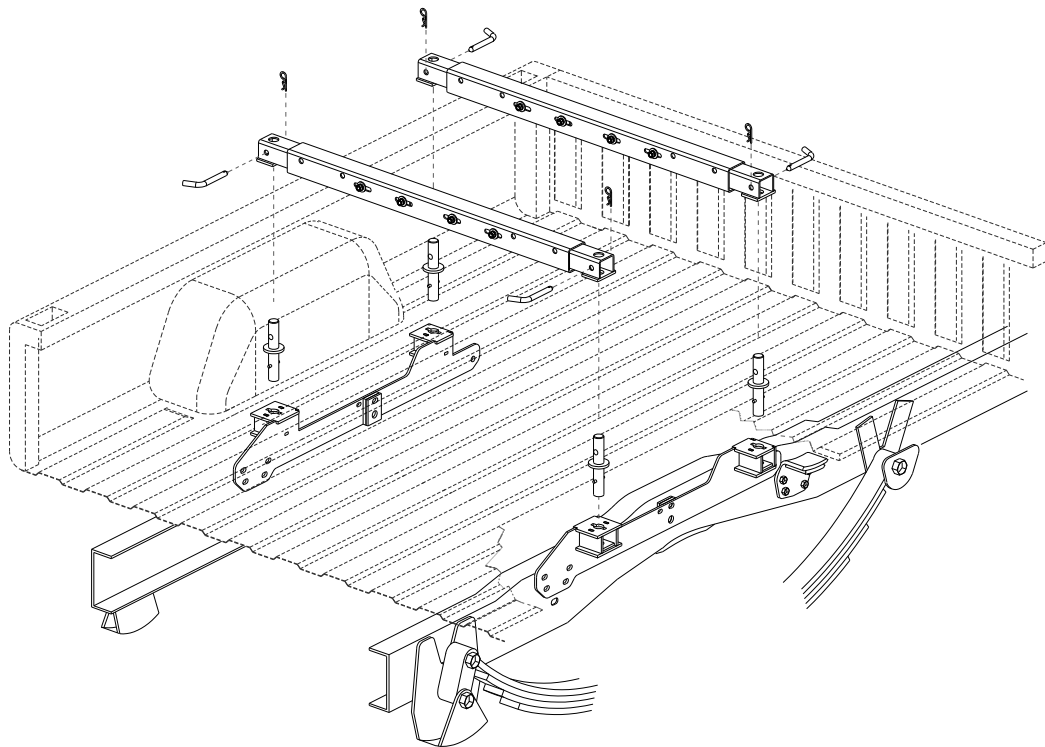

Ford Base Rail illustration

FORD SD continued

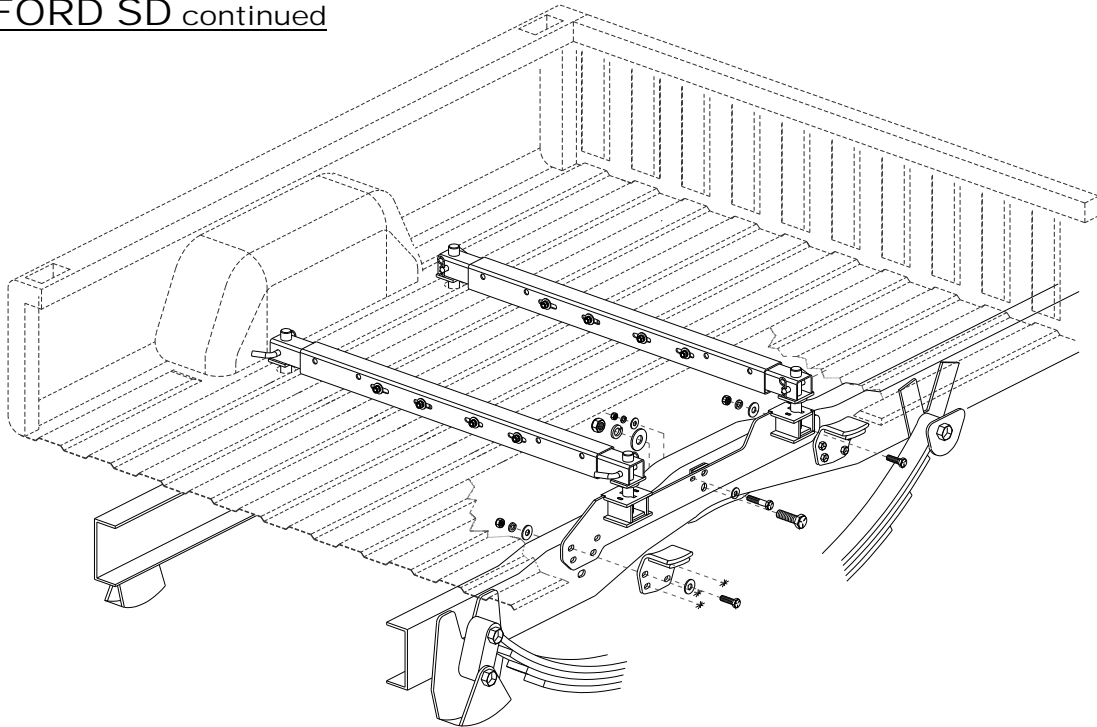

Cutaway view, of Mounting Plate installation

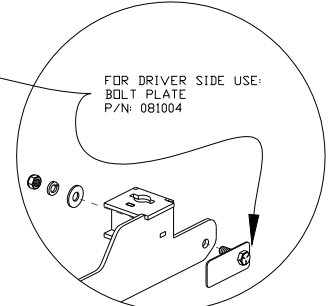
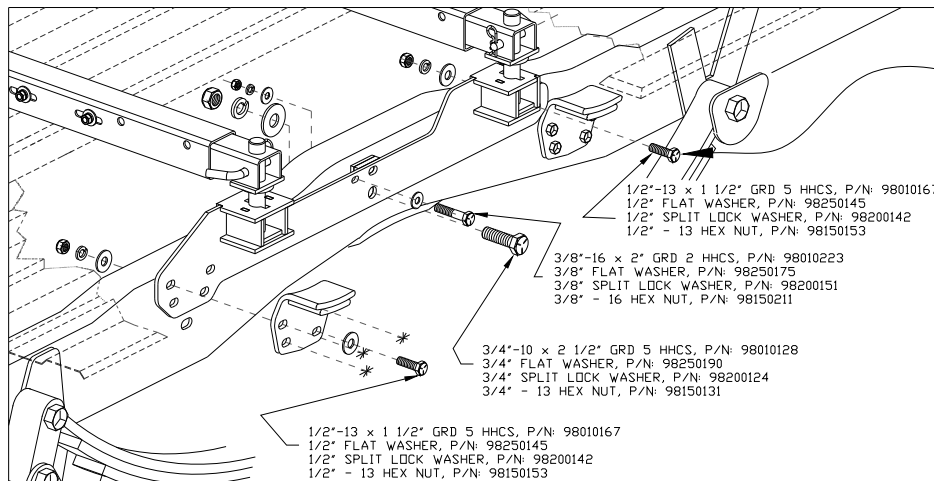

Note: The 3/8" x 2" bolt shown, is only present on the driver side of the vehicle. This bolt holds the brake cable.

The insert on the right side shows the use of a BOLT PLATE for the driver side mounting bracket. This plate is necessary because of the limited clearance between the truck frame and the gas tank.

Detail view of Mounting Plate installation

99-08 FORD SUPER DUTY				SUPER RAIL MOUNTING KIT
WEIGHT 84 LBS	P/N	0841		
MOUNTING POST	330701	4		BASE RAIL MOUNTING POSTS
** LAYOUT TEMPLATE	08510000	1		
MOUNTING BRACKET KIT	0851	1 KIT		MOUNTING BRACKET KIT
MOUNTING POST BRACKET	085101	1		DRIVERS SIDE
MOUNTING POST BRACKET	085102	1		PASSENGER SIDE
1/2" FRAME BOLTS	98010167	9		1/2"-13 x 1 1/2" HHCS GRD 5
1/2" FLAT WASHER	98250145	18		1/2" FLAT WASHER
BOLT PLATE	081004	1		DRIVER SIDE BOLT PLATE
1/2" SPLIT LOCK WASHER	98200142	10		1/2" SPLIT LOCK WASHER
1/2" - 13 HEX NUT	98150153	10		1/2" - 13 HEX NUT
3/8" BRAKE CABLE BOLT	98010223	1		3/8"-16 x 2" HHCS, GRD 5
3/8" FLAT WASHER	98250175	2		3/8" FLAT WASHER
3/8" LOCK WASHER	98200151	1		3/8" LOCK WASHER
3/8" - 16 HEX NUT	98150211	1		3/8" - 16 HEX NUT
3/4" FRAME BOLTS	98010128	2		3/4"-10x2 1/2" HHCS GRD 5
3/4" FLAT WASHER	98250190	2		3/4" FLAT WASHER
3/4" LOCK WASHER	98200124	2		3/4" LOCK WASHER
3/4"-10 HEX NUT	98150131	2		3/4"-10 HEX NUT
BASE RAIL ASSEMBLY KIT	0840	1 KIT		BASE RAIL ASSEMBLY KIT
BASE RAIL	084001	2		BASE RAIL
BASE RAIL EXTENSION	084002	4		BASE RAIL EXTENSION
BASE RAIL HARDWARE KIT	084003	1 KIT		BASE RAIL HARDWARE KIT
BASE RAIL PIN	08060001	4		BASE RAIL PIN
COTTER PIN	98410127	4		#3 COTTER PIN
BASE RAIL BOLT	98050140	8		3/8"-16 X 3 1/2" CARRIAGE GRD. 5
BASE RAIL FLAT WASHER	98250175	8		3/8" FLAT WASHER
BASE RAIL LOCK WASHER	98200151	8		3/8" LOCK WASHER
BASE RAIL HEX NUT	98150211	8		3/8" - 16 HEX NUT
NOTE: ** = NOT INCLUDED IN KIT.				

DODGE, 1995 to 2002 Except 2002 1/2 Ton

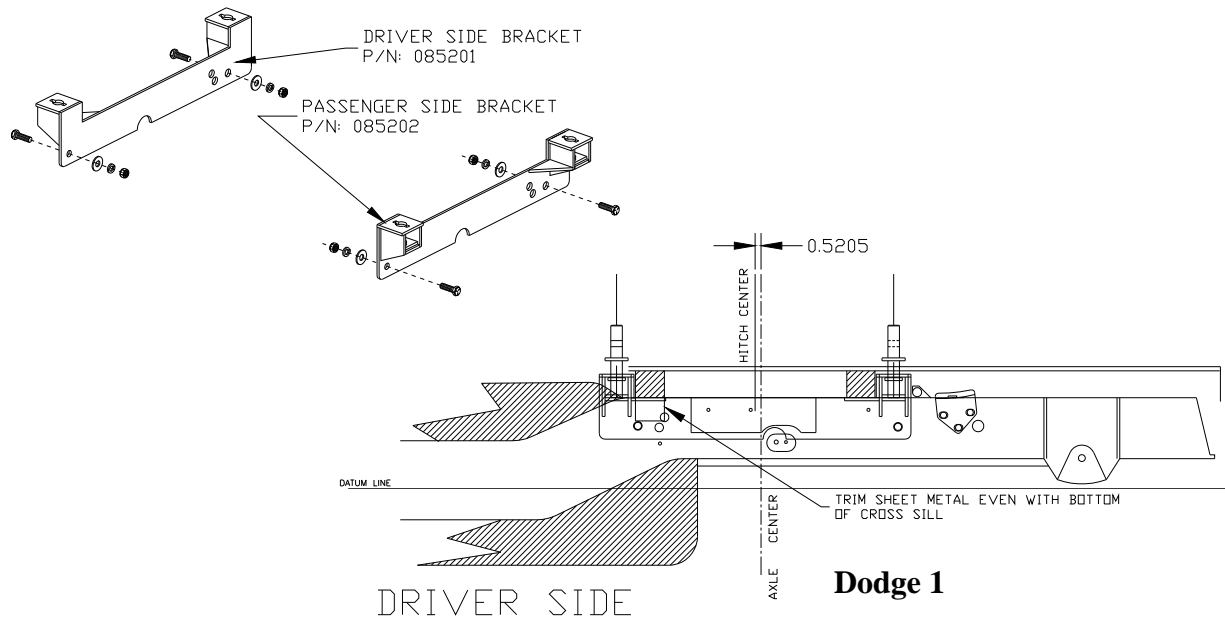

PART I Truck Preparation

1. For the 6' bed truck, cut off the lower sheet metal support as shown illustrated in figure **Dodge-1** on both the driver side and passenger side of the truck bed, if this sheet metal exists.

Mounting Bracket Installation.

1. Locate the two existing holes that are to be used to mount the front Mounting Bracket, as shown in the drawing of **Dodge 1**. Install the Mounting Bracket over the holes, using 5/8" x 1 1/2" bolts. Tighten sufficiently to hold the Mounting bracket tight against the frame.
2. Install the Mounting Brackets on the passenger side repeating steps 1.
3. Drill the four pilot holes in the truck bed where you marked the bed during Truck Bed Layout. Check each of the holes to be sure that the pilot hole is centered in the Mounting Post Hole. Adjust the drill holes if needed. Keep in mind that realigning any one hole will affect the relative spacing of the other pilot holes. The pilot hold should come down in the center of the Mounting Post hole of the bracket.
4. Remove the four Mounting Brackets, and return to the General Instructions on pages 5 & 6 continue with 'Drilling the Bed'.

PART II Mounting Bracket installation continued.

1. Install the Mounting brackets using the 5/8" x 1 1/2" bolts provided. The hardware is illustrated in the **Detail View of Mounting Plate Installation** on page 12 .
2. Tighten all the previous installed mounting bolts on the Mounting Brackets. Torque all bolts per the table on pg. 6.
3. You may wish to remove and install the 5th Wheel Hitch to be sure the hitch will go on and off freely.

DODGE, Continued

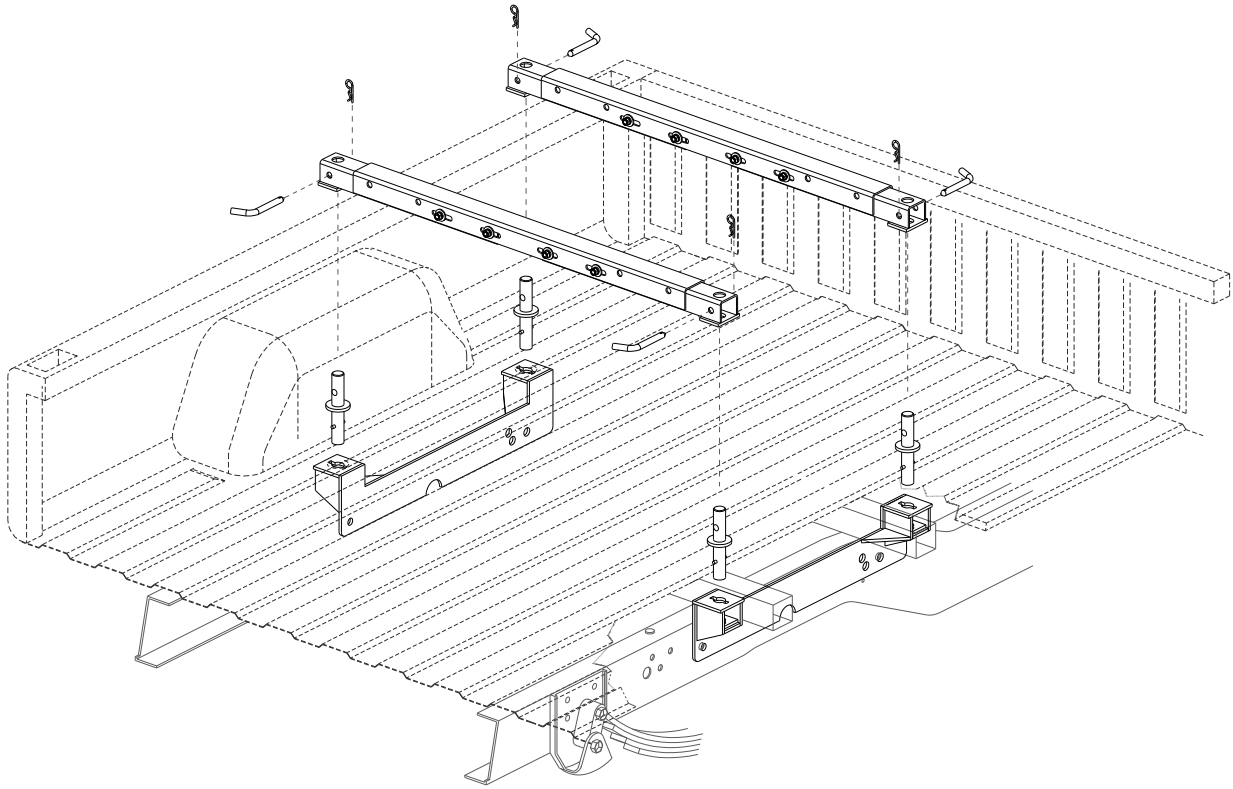

Cutaway view of Base Rail Installation

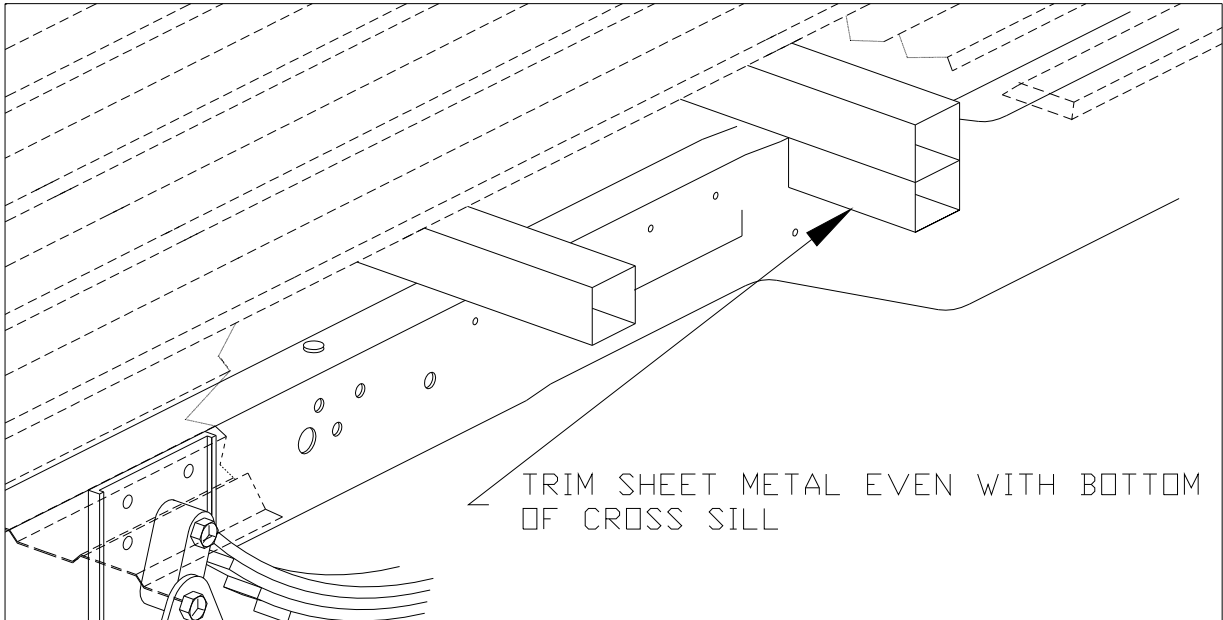

TRIM SHEET METAL EVEN WITH BOTTOM OF CROSS SILL

Enlarged Cutaway view of truck bed

DODGE, Continued

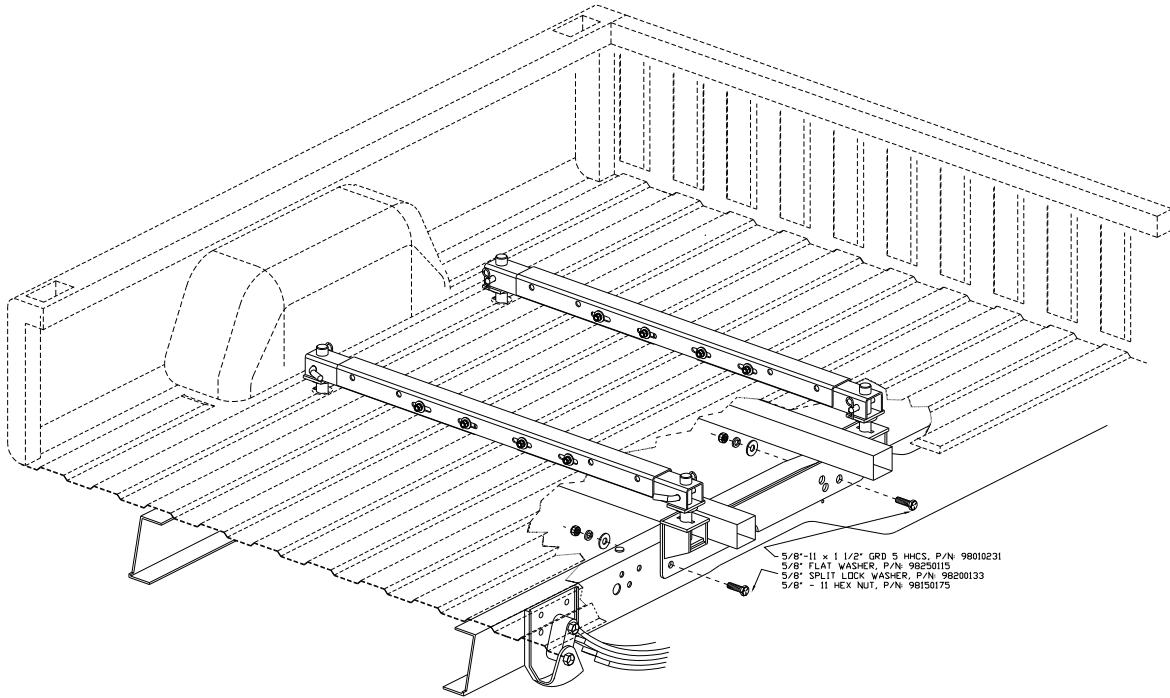

Dodge Base Rail Illustration

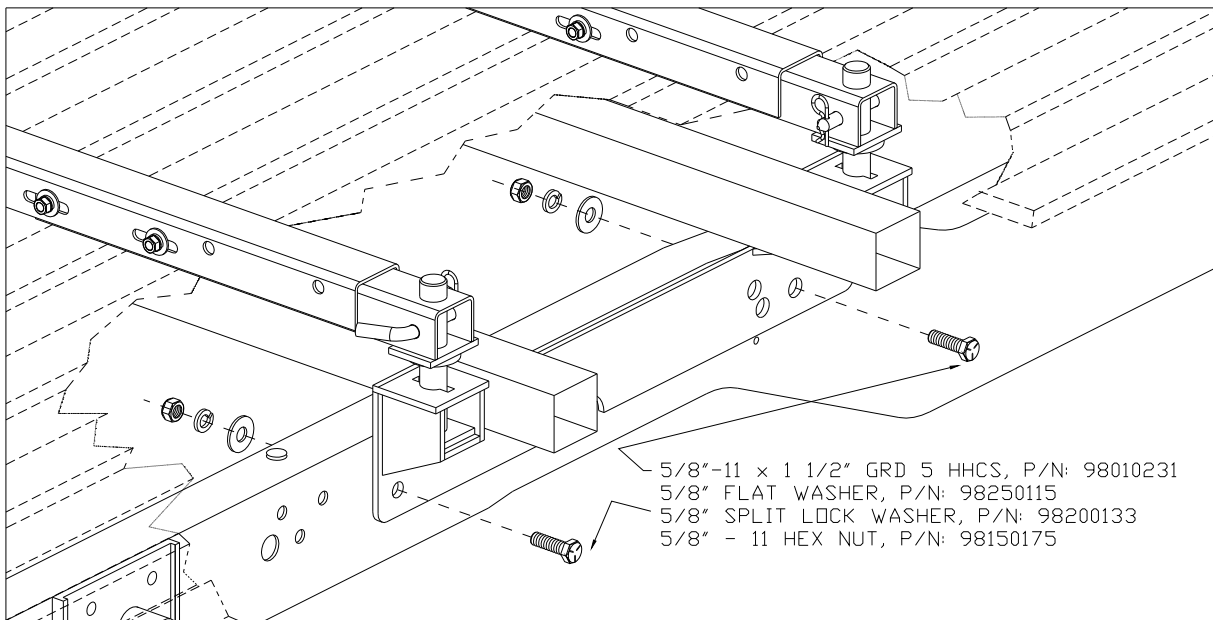

Dodge Detail Base Rail Illustration

DODGE				SUPER RAIL MOUNTING KIT
WEIGHT 77 LBS	P/N	0842		
MOUNTING POST	330701	4		BASE RAIL MOUNTING POST
*** LAYOUT TEMPLATE	08520000	1		
MOUNTING BRACKET KIT	0852	1 KIT		MOUNTING BRACKET KIT
MOUNTING POST BRACKET	085201	1		DRIVERS SIDE
MOUNTING POST BRACKET	085202	1		PASSENGER SIDE
5/8", FRAME BOLTS	98010231	4		5/8"-11 x 1 1/2" HHCS GRD 5
5/8" FLAT WASHER	98250115	4		5/8" FLAT WASHER
5/8" SPLIT LOCK WASHER	98200133	4		5/8" SPLIT LOCK WASHER
5/8" - 11 HEX NUT	98150175	4		5/8" - 11 HEX NUT
BASE RAIL ASSEMBLY KIT	0840	1 KIT		BASE RAIL ASSEMBLY KIT
BASE RAIL	084001	2		BASE RAIL
BASE RAIL EXTENSION	084002	4		BASE RAIL EXTENSION
BASE RAIL HARDWARE KIT	084003	1 KIT		BASE RAIL HARDWARE KIT
BASE RAIL PIN	08060001	4		BASE RAIL PIN
COTTER PIN	98410127	4		#3 COTTER PIN
BASE RAIL BOLT	98050140	8		3/8"-16 X 3 1/2" CARRIAGE GRD. 5
BASE RAIL FLAT WASHER	98250175	8		3/8" FLAT WASHER
BASE RAIL LOCK WASHER	98200151	8		3/8" LOCK WASHER
BASE RAIL HEX NUT	98150211	8		3/8" - 16 HEX NUT
NOTE: ** = NOT INCLUDED IN KIT.				

CHEVY 1999-2008 HD & 1999-2008 LD

HARDWARE

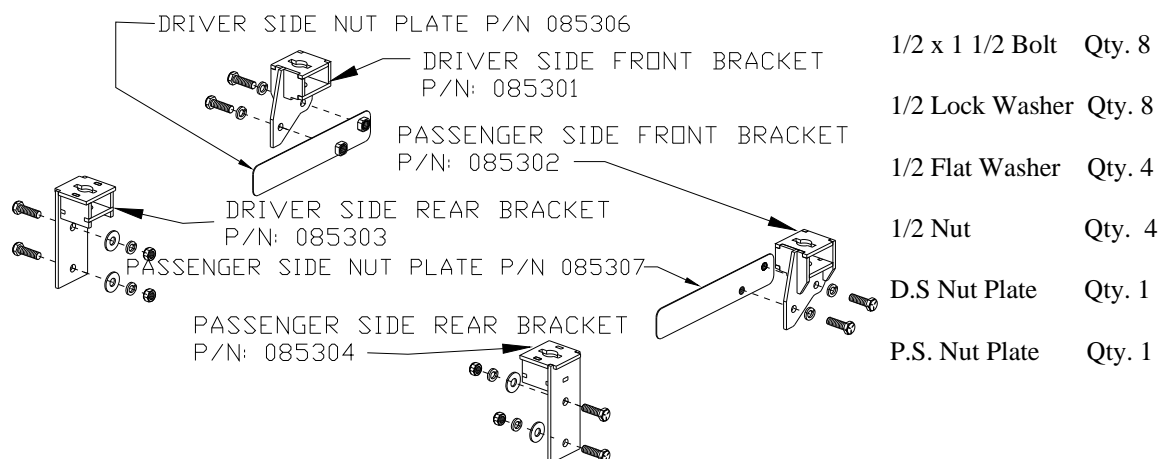

Part I Truck Preparation

1. Take note of drawing Chevy-1. It should help you position the Mounting Brackets.

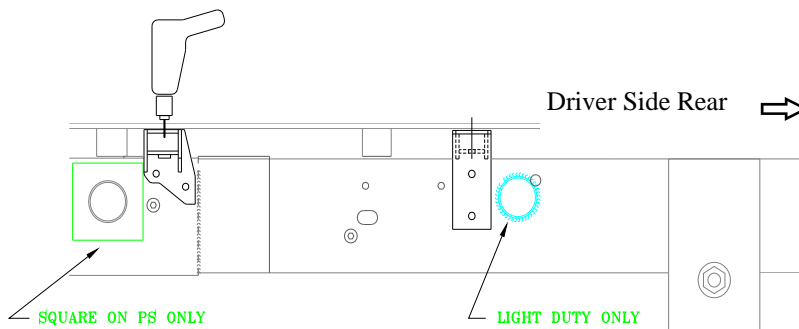

Chevy - 1

Mounting Bracket Installation.

1. From the truck bed, drill a 1/16" pilot hole over the forward most driver side hole that you marked during layout. Then slide the Front Driver Side Mounting Bracket up in place, holding it firmly against the truck frame. Check to see if the 1/16" hole aligns with the center of the Mounting Bracket Post Hole.
2. If the drill bit missed the center of the hole in the Mounting Bracket, check your measurements again. Re-drill the hole if necessary to get correct alignment. Adjust the other hole markings for the remaining three holes if needed. Drill the pilot holes for the remaining three hole and check each hole using it's appropriate Mounting Bracket. Once the alignment looks good, remove the brackets.
3. Go to "Drilling the Bed" on pages 5 & 6.

Part II. Mounting Bracket installation continued.

1. Drill the frame holes for the Mounting Brackets, using a 1/2" drill bit.
2. Install the 1/2 x 1 1/2" bolts to secure the Mounting Brackets to the frame. The front Mounting Brackets require Nut Plates, so start both bolts into the Nut Plate before you begin tightening the bolts. (Refer to the drawing above, and on page 18).
3. Tighten all bolts, torque all bolts per the table on page 6.

CHEVY HD & LD, Continued

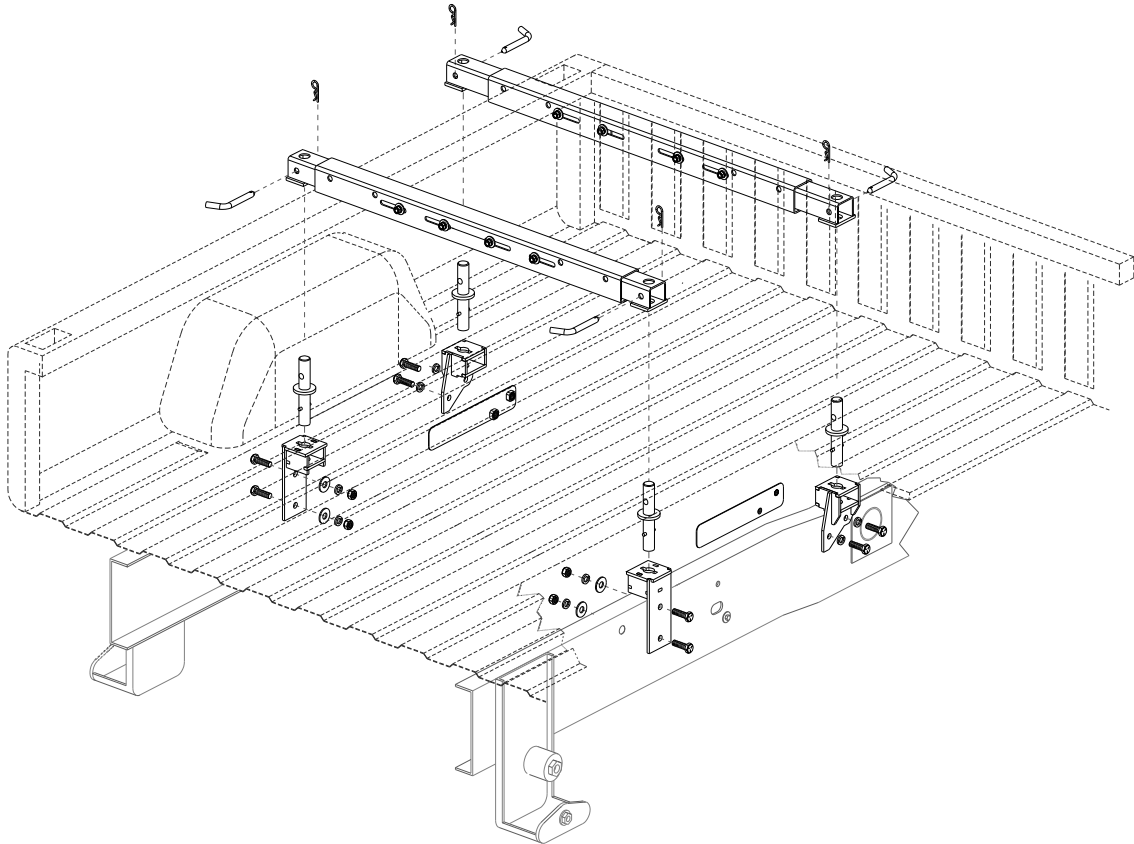

Base Rail Cutaway View Illustration

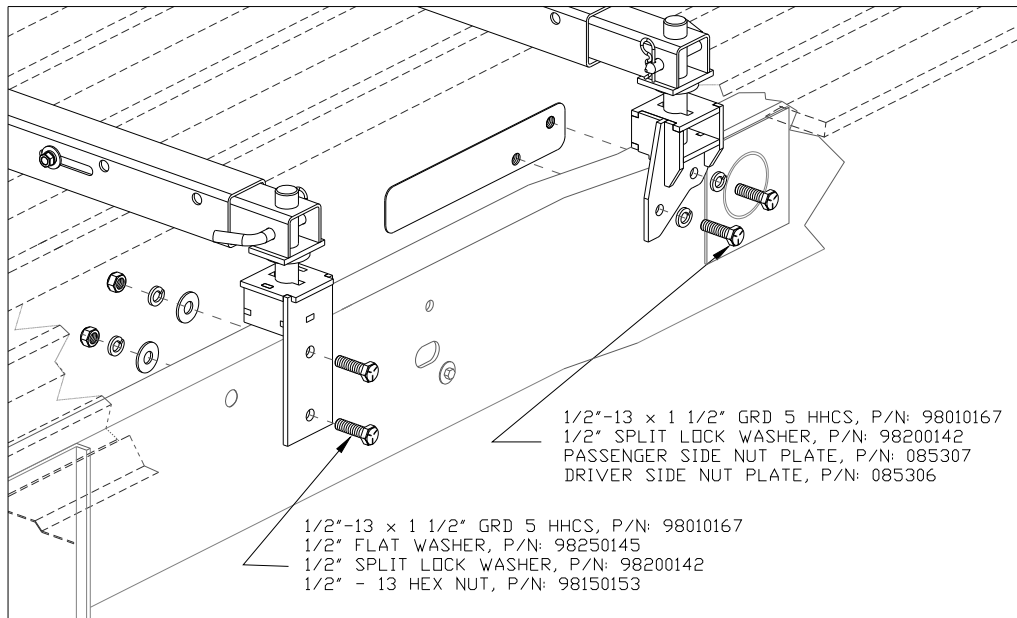

Base Rail Detail View Illustration

CHEVY				SUPER RAIL MOUNTING KIT
WEIGHT 65 LBS	P/N	0843		
MOUNTING POST	330701	4		BASE RAIL MOUNTING POST
** LAYOUT TEMPLATE	08530000	1		
MOUNTING BRACKET KIT	0853	1 KIT		MOUNTING BRACKET KIT
MOUNTING POST BRACKET	085301	1		DRIVERS SIDE FRONT BRACKET
MOUNTING POST BRACKET	085302	1		PASSENGER SIDE FRONT BRACKET
MOUNTING POST BRACKET	085303	1		DRIVERS SIDE REAR BRACKET
MOUNTING POST BRACKET	085304	1		PASSENGER SIDE REAR BRACKET
1/2", FRAME BOLTS	98010167	8		1/2"-13 x 1 1/2" HHCS GRD 5
1/2" FLAT WASHER	98250145	4		1/2" FLAT WASHER
1/2" SPLIT LOCK WASHER	98200142	8		1/2" SPLIT LOCK WASHER
1/2" - 11 HEX NUT	98150153	4		1/2" - 13 HEX NUT
DRIVER SIDE NUT PLATE	085306	1		DRIVER SIDE NUT PLATE
PASSENGER SIDE NUT PLATE	085307	1		PASSENGER SIDE NUT PLATE
BASE RAIL ASSEMBLY KIT	0840	1 KIT		BASE RAIL ASSEMBLY KIT
BASE RAIL	084001	2		BASE RAIL
BASE RAIL EXTENSION	084002	4		BASE RAIL EXTENSION
BASE RAIL HARDWARE KIT	084003	1 KIT		BASE RAIL HARDWARE KIT
BASE RAIL PIN	08060001	4		BASE RAIL PIN
COTTER PIN	98410127	4		#3 COTTER PIN
BASE RAIL BOLT	98050140	8		3/8"-16 X 3 1/2" CARRIAGE GRD. 5
BASE RAIL FLAT WASHER	98250175	8		3/8" FLAT WASHER
BASE RAIL LOCK WASHER	98200151	8		3/8" LOCK WASHER
BASE RAIL HEX NUT	98150211	8		3/8" - 16 HEX NUT
NOTE: ** = NOT INCLUDED IN KIT.				

Dodge 2003-2008, 3/4 ton 2x4 & 4x4, & 1 Ton 4 x 4

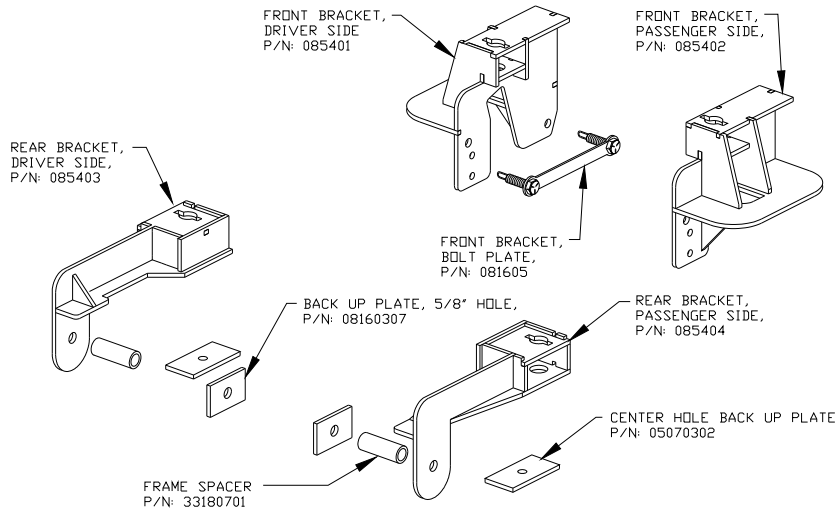

HARDWARE

1/2 x 7 1/2" Bolt	Qty. 2
1/2 Lock Washer	Qty. 6
1/2 Flat Washer	Qty. 4
1/2 Nut	Qty. 4
5/8" x 4 1/2" Bolt	Qty. 2
5/8" Lock Washer	Qty. 2
5/8" Nut	Qty. 2

PART I Truck Preparation

After blocking the front wheels, place jack stands under the frame so that the rear of the truck is high enough to allow the rear wheels to drop. This will give easy access to the frame area in the rear wheel well. Remove the emergency brake cable bracket located in the driver side wheel well, refer to figure 1 on this page. Replace this bracket after installing the hitch mounting brackets. If the truck is a **two wheel drive**, remove the axle jounce bumper located just above the axle on the bottom of the frame, replace after the hitch is installed. If the truck is a **two wheel drive one ton**, this mounting system will **not** work.

Refer to figure 1 this page, if the installation is for a six foot bed truck. Trim the cross sill extensions located under the front bed cross sill even with the bottom of the main cross sill as they will interfere with the installation of the Front Mounting Bracket.

Mounting Bracket Installation.

1. From the truck bed, drill a 1/16" pilot hole over the forward most Driver side hole that you marked during layout on page 7. Slide the Rear Driver Side Mounting Bracket up in place, holding it firmly against the truck frame. Check to see if the 1/16" hole aligns with the center of the Mounting Bracket Post Hole.
2. If the drill bit missed the center of the hole in the Mounting Bracket, check your measurements again. Re-drill the hole if necessary to get correct alignment. Adjust the other hole markings for the remaining three holes if needed. Drill the pilot holes for the remaining three holes and check each hole using it's appropriate Mounting Bracket. Once the alignment looks good, remove the brackets.
3. Go to "**Drilling the Bed**" on pages 5 & 6.

Fig. 1

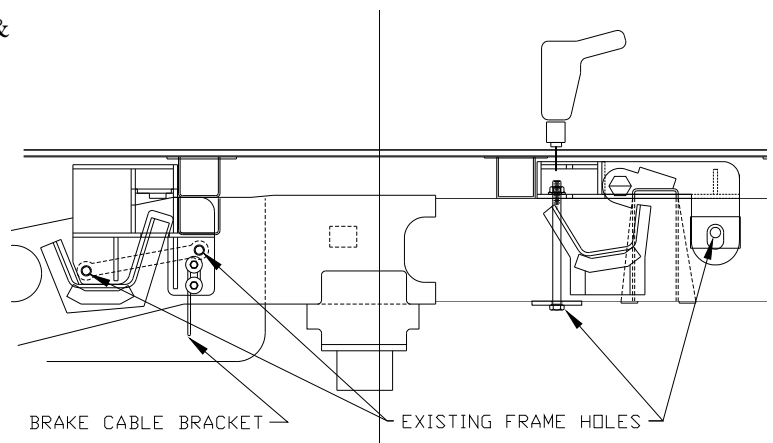

Dodge 2003-2008, 3/4 ton 2x4 & 4x4, & 1 Ton 4 x 4, Continued

Part II. Mounting Bracket installation continued.

1. Find the Bolt Plate with welded 1/2" bolts P/N: 081605 in the Hardware Kit. Make sure that the 1/2" Hex Nuts will thread on to the bolts and that the bolts will fit into the existing frame holes, see figure 2 this page.
2. Find the existing frame holes as shown in figure 3 this page. The 5/8" Front Bracket holes and the large round holes located on the bottom of the frame towards the rear of the truck.
3. Insert a "fish" wire into the front 5/8" existing frame hole and thread it towards the large hole located on the bottom of the frame at the rear, see the figure below. Use a short piece of wire, fashioned like a fish hook, to insert into the large hole to snare the "fish" wire down through the large hole.
4. Attach the "fish" wire to the eyelet welded to the bolt portion of the Bolt Plate P/N: 081605, also attach another wire to the small hole located in one end of the Bolt Plate to be used as a retrieval wire if the "fish" wire should break. Be sure the first wire is attached to the bolt welded to the opposite end of the retrieval wire hole.
5. Repeat steps 3 and 4 for the rear 5/8" existing frame hole and second bolt of the Bolt Plate. This wire should be attached to the bolt nearest the retrieval wire hole.
6. When running the "fish" wire through the passenger side frame be careful to avoid running the wire over the top of the muffler brackets. The muffler brackets are rods that run through the frame rail and welded in place. If the "fish" wire is run over the top of these rods the Bolt Plate will not pass over them. Remove axle jounce bumpers for two wheel drive trucks only.
7. Gently pull the Bolt Plate through the large rear hole and out through the front existing frame holes. Make sure the bolt nearest the retrieval wire goes through last.
8. Position the Mounting Bracket on the frame so that the 1/2" bolt of the Bolt Plate passes through the pre drilled holes in the Mounting Bracket. Secure the Mounting Bracket in place by threading the 1/2"-13 Hex Nuts, 1/2" Lock Washers and 1/2" Flat Washers on to the 1/2" bolt of the Bolt Plate, see figure 3 this page and figure 4 on page 22. Finger tighten only.

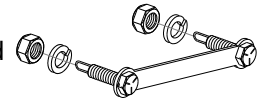
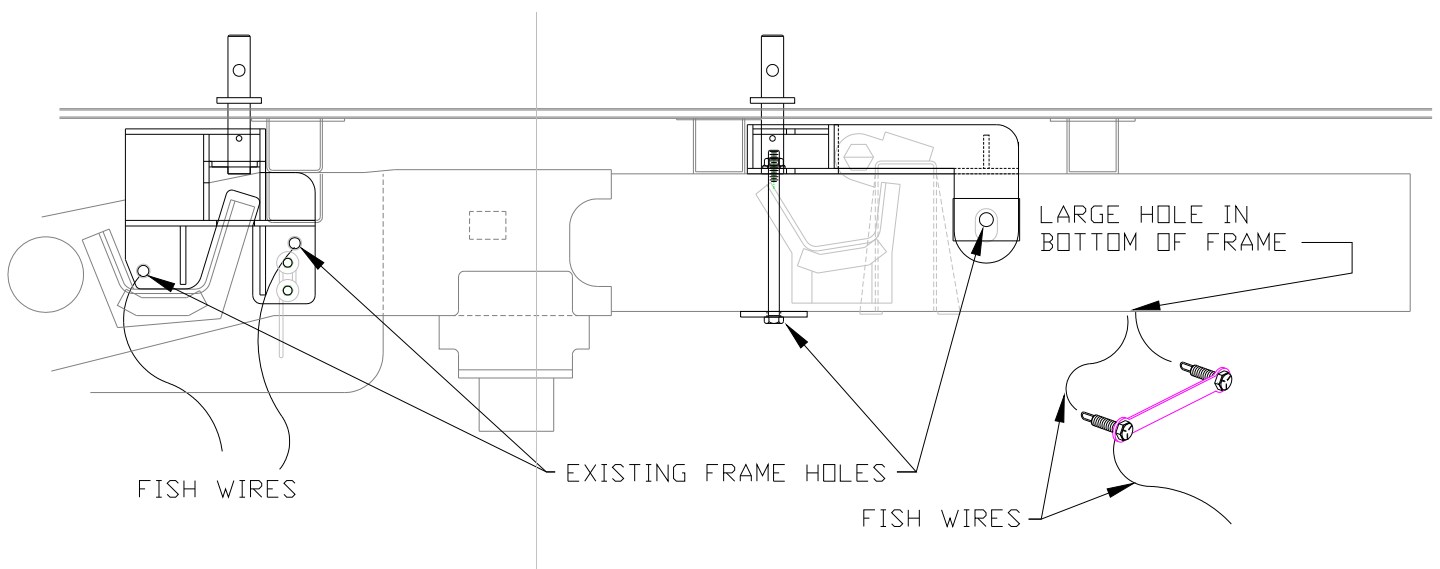

Fig. 2.

Fig. 3



Dodge 2003-2008, 3/4 ton 2x4 & 4x4, & 1 Ton 4 x 4, Continued

FRONT MOUNTING BRACKET INSTALLATION

Fig. 4

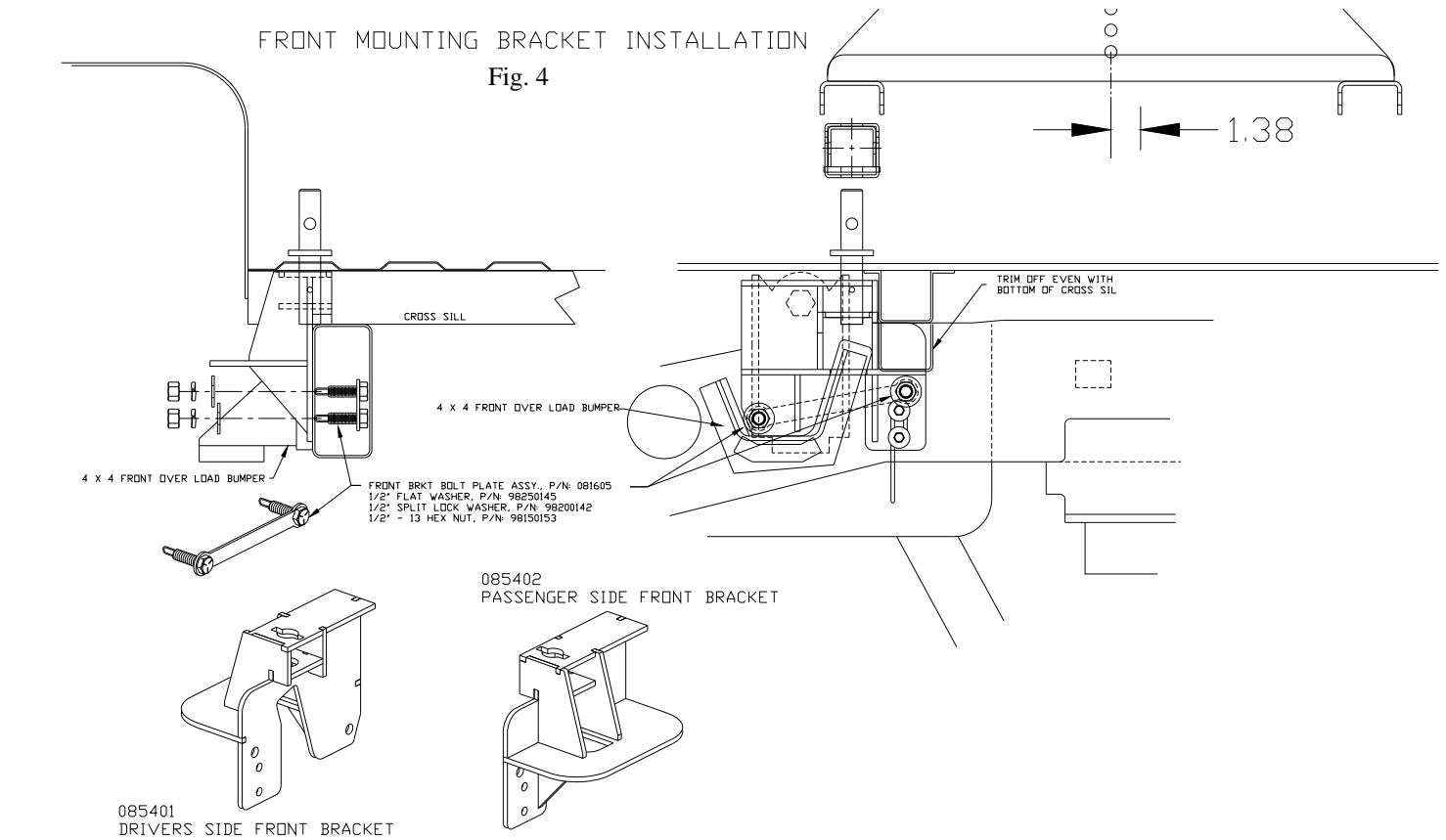

REAR MOUNTING BRACKET INSTALLATION

Fig. 5

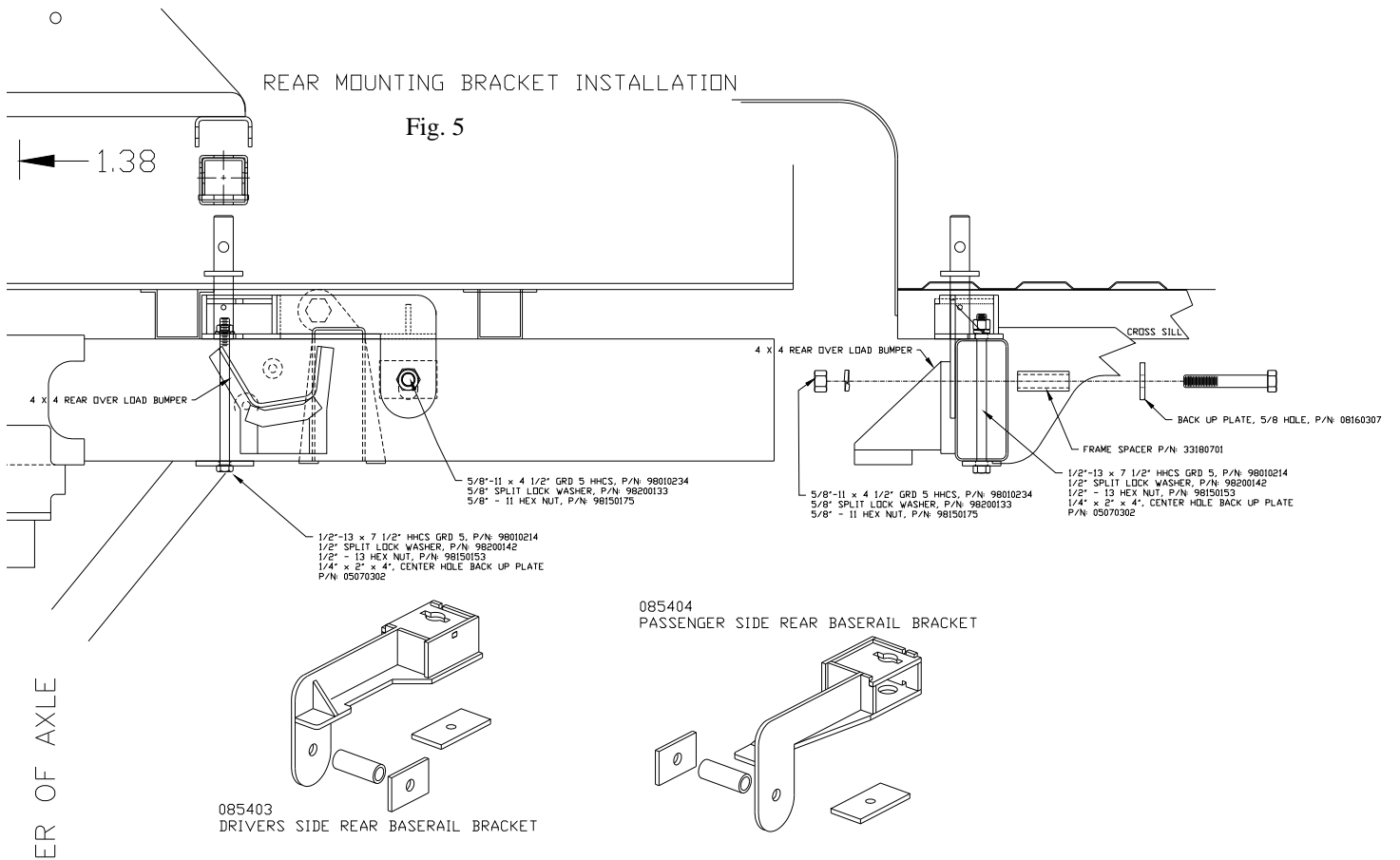

Dodge 2003-2008, 3/4 ton 2x4 & 4x4, & 1 Ton 4 x 4, Continued

- 1) Referring to figure 5 on page 22, install the Rear Mounting Brackets P/N: 085403 and 085404. When fastening the Rear Mounting Bracket rear hole location, make sure that the Frame Shim P/N: 33180701 is installed so that it does not extend past the side wall of the frame. This will insure that the 5/8"-11 x 4 1/2" Bolt will fasten the Rear Mounting Bracket tightly to the frame. If the Frame Shim **does** extend past the side wall of the frame, it is either made too long or it is not seated properly against the Mounting Bracket through the opposite obround hole. Finger tighten the 5/8"-11 Hex Nut and 5/8" Split Lock Washer.
- 2) To fasten the Rear Mounting Bracket front hole location, find the obround hole located in the bottom of the frame rail just below and slightly behind the cross sill located just ahead of the Rear Mounting Bracket position. Referring to figures 5 and 6, fasten the Rear Mounting Bracket at this location using the 1/2"-13 x 7 1/2" Bolt, Center Hole Back Up Plate P/N: 05070302 and 1/2" Lock Washer (nut is welded to the bracket). Finger tighten only.
- 3) Return to pages 5 & 6 steps 4 through 12 to complete installation of hitch.
- 4) Torque all bolts per Torque Table specifications located on page 6

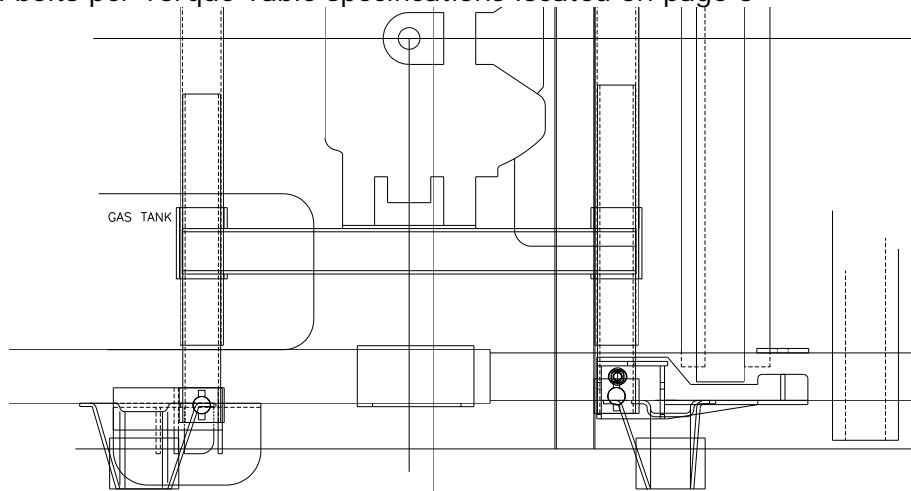
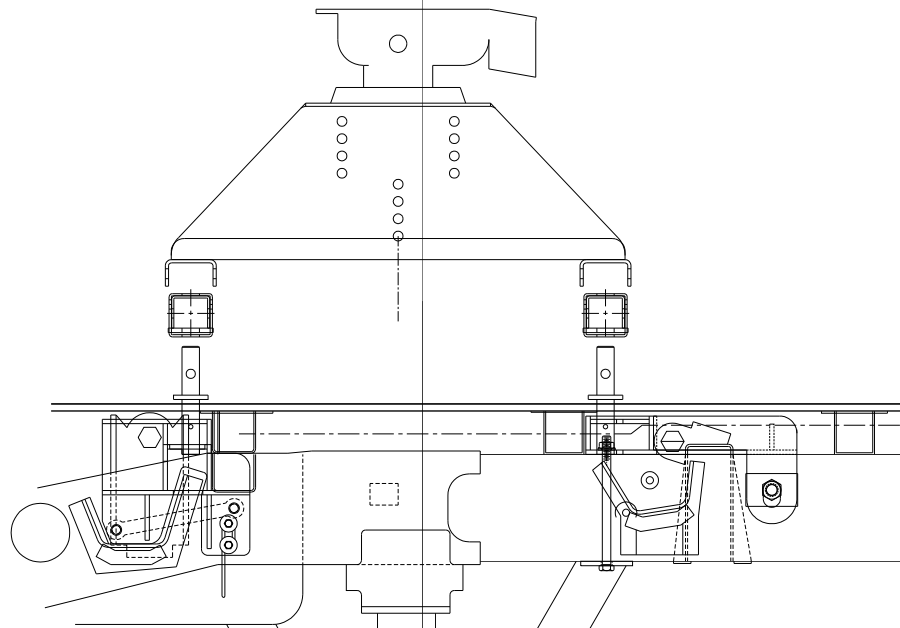

Fig. 6



2003-2008 DODGE	P/N	0844	SUPER RAIL MOUNTING KIT
WEIGHT 89 LBS			
MOUNTING POST	330701	4	BASE RAIL MOUNTING POST
*** LAYOUT TEMPLATE	08540000	1	
MOUNTING BRACKET KIT	0854	1 KIT	MOUNTING BRACKET KIT
FRONT MOUNTING BRACKET	085401	1	DRIVER SIDE
FRONT MOUNTING BRACKET	085402	1	PASSENGER SIDE
REAR MOUNTING BRACKET	085403	1	DRIVER SIDE
REAR MOUNTING BRACKET	085404	1	PASSENGER SIDE
FRONT BRACKET BOLT PLATE	081605	2	
REAR BRKT., 5/8" HLOE, BACK UP PLATE	08160307	2	1/4" x 3" x 1 7/8", WITH 5/8" HOLE
REAR BRACKET, FRAME SPACER	33180701	2	1" RD. TUBING x 2 3/4"
BACK UP PLATE, CENTER HOLE	08070302	2	1/4" x 2" x 4", WITH 1/2" HOLE
1/2" FLAT WASHER	98250145	4	1/2" FLAT WASHER
1/2" SPLIT LOCK WASHER	98200142	6	1/2" SPLIT LOCK WASHER
FRONT BRACKET FRAME NUTS	98150153	4	1/2" - 13 HEX NUT
1/2", REAR FRAME BOLTS	98010214	2	1/2"-13 x 7 1/2" HHCS GRD 5
5/8" REAR FRAME BOLTS	98010231	2	5/8"-11 x 1 1/2" GRD. 5 HHCS
5/8" REAR FRAME BOLT, LOCK WASHER	98200133	2	5/8" SPLIT LOCK WASHER
5/8" REAR FRAME BOLT, HEX NUT	98150175	2	5/8"-11 HEX NUT
BASE RAIL ASSEMBLY KIT	0840	1 KIT	BASE RAIL ASSEMBLY KIT
BASE RAIL	084001	2	BASE RAIL
BASE RAIL EXTENSION	084002	4	BASE RAIL EXTENSION
BASE RAIL HARDWARE KIT	084003	1 KIT	BASE RAIL HARDWARE KIT
BASE RAIL PIN	08060001	4	BASE RAIL PIN
COTTER PIN	98410127	4	#3 COTTER PIN
BASE RAIL BOLT	98050140	8	3/8"-16 X 3 1/2" CARRIAGE GRD. 5
BASE RAIL FLAT WASHER	98250175	8	3/8" FLAT WASHER
BASE RAIL LOCK WASHER	98200151	8	3/8" LOCK WASHER
BASE RAIL HEX NUT	98150211	8	3/8" - 16 HEX NUT
NOTE: ** = NOT INCLUDED IN KIT.			



MANUFACTURED BY
PULLIAM ENTERPRISES, INC.
13790 East Jefferson Blvd.
Mishawaka, IN 46545
(574) 259-1520 • (800) 443-2307
info@pullrite.com • www.pullrite.com