



Super 5th Towing Solutions

INSTALLATION INSTRUCTIONS

SPECIFICATIONS:

16,000 Super 5th, (Part #1200)	
Gross Trailer Weight (Maximum).....	16,000 lbs.
Vertical Load Weight (Max. Pin Weight).....	4,000 lbs.
20,500 Super 5th, (Part #0800)	
Gross Trailer Weight (Maximum).....	20,500 lbs.
Vertical Load Weight (Max. Pin Weight).....	5,125 lbs.

FOR USE WITH
'95-'01 DODGE 1500, 2500, 3500 TRUCKS
2002 DODGE 2500 & 3500 TRUCKS
HITCH IS LOCATED 1.63" AHEAD OF AXLE
CUSTOM MOUNTING BRACKETS (Part # 0812)
CUSTOM MOUNTING KIT (PART # 0824)

Introduction

The following steps provide several pages of general instruction for the installation of the **16,600# (part number 1200)** and **20,500# (part number 0800) SUPER 5TH** towing system. Should you have any questions, please call the factory at (800) 443-2307 for installation assistance.

Index

Page

Introduction	1
Parts List For 20,500# Hitch	2
Parts List For 16,000# Hitch	3
Parts List For Custom Mounting Brkt & Tools Needed for Installation	4
Super 5th Preparation, Vehicle Preparation & Laying Out and Marking the Bed	5
Installation Tip & Drilling the Bed	6
Hitch Assembly & Hitch Installation	7
Installation Tips & General Comments	8

Parts List For 20,500 Super 5th Hitch

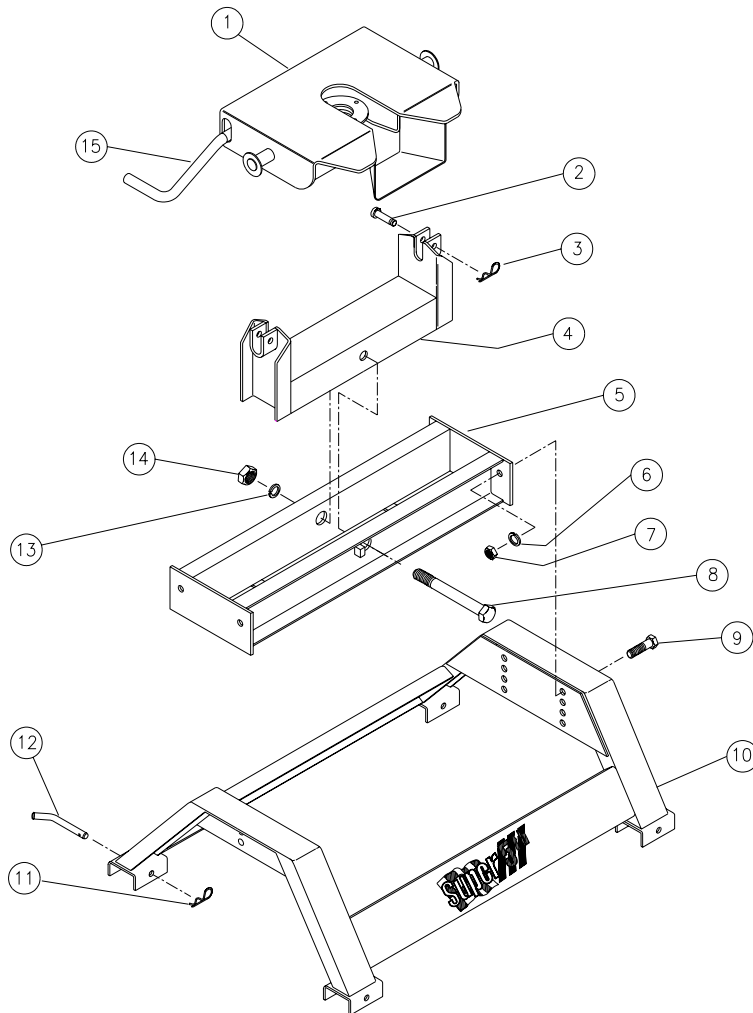

Ref	Item	Part #	Qty
1.	Fifth Wheel Plate	3601	1
2.	1/2 Clevis Pin	98410111	2
3.	#3 Pin Clip	98410127	2
4.	Rocker Arm	0802	1
5.	Crossmember	0803	1
6.	1/2" Lock washer	98200142	4
7.	1/2"-13 Hex Nut	98150153	4
8.	3/4" x 7" Pivot Bolt	98010147	1
9.	1/2"-13 x 1 1/2" Bolt	98010167	4
10.	Base	0804	1
11.	#3 Pin Clip	98410127	4
12.	1/2" Base Rail Pin	08060001	4
13.	3/4" Lock washer	98200124	1
14.	3/4"-10 Hex Nut	98150131	1
15.	Release Handle	350104	1

Parts List For 16,000 Super 5th Hitch

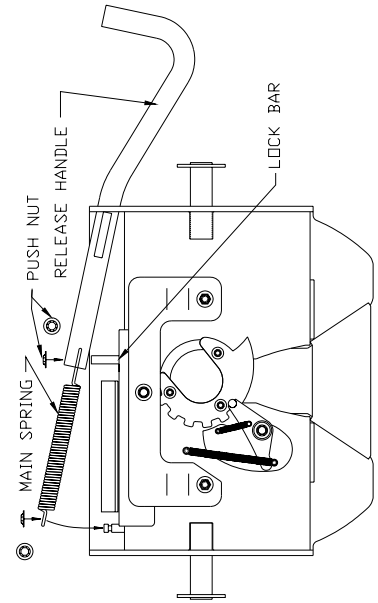
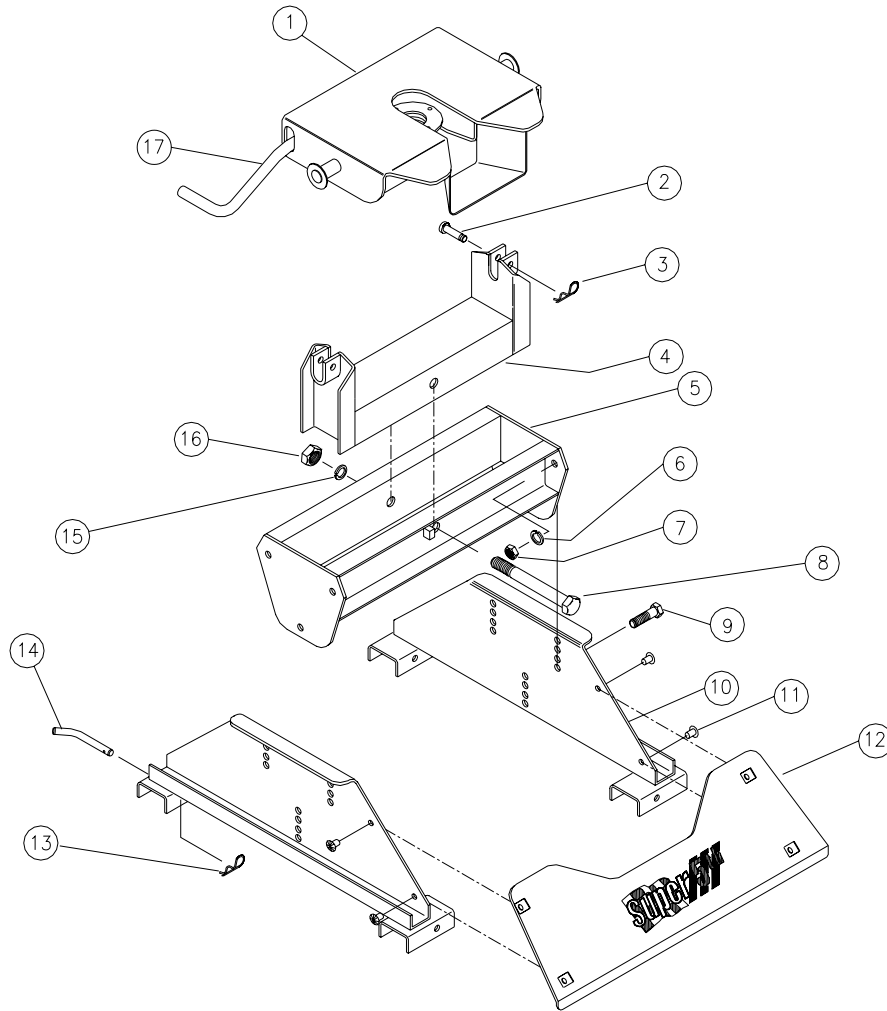

Ref	Item	Part #	Qty
1.	Fifth Wheel Plate	3601	1
2.	½ Clevis Pin	98410111	2
3.	#3 Pin Clip	98410127	2
4.	Rocker Arm	0802	1
5.	Crossmember	1202	1
6.	½" Lock washer	98200142	6
7.	½"-13 Hex Nut	98150153	6
8.	¾" x 7" Pivot Bolt	98010147	1
9.	½"-13 x 1 ½" Bolt	98010167	6
10.	Base Side	120301	2
11.	Plastic Xmas Tree		4
12.	Base Cover	120302	1
13.	#3 Pin Clip	98410127	4
14.	½" Base Rail Pin	08060001	4
15.	¾" Lock washer	98200124	1
16.	¾"-10 Hex Nut	98150131	1
17.	Release Handle	350104	1

Parts List For Dodge Super 5th Custom Mounting Brackets

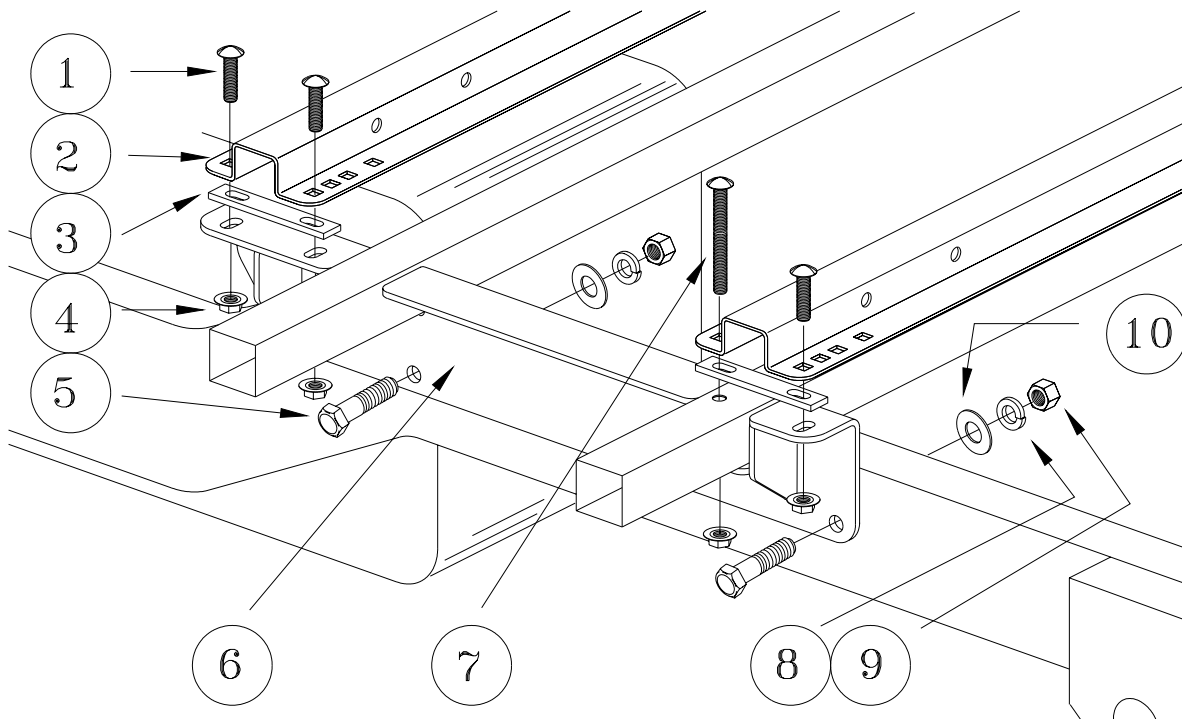

Ref.	Item	Part #	Qty
1.	1/2"-13 x 2" Carriage Bolt	98050110	6
2.	Base Rails	08050001	2
3.	Bed Channel Spacer [dbl. slot, 1/4" x 1" x 6"]	05070301	4
4.	1/2"-13 Flange Nut	98150201	8
5.	5/8"-11 x 1 1/2" Hex Bolt	98010231	4
6.	Mounting Brackets	0812	1 set
7.	1/2"-13 x 5" Carriage Bolt	98050128	2
8.	5/8" Lock Washer	98200133	4
9.	5/8"-11 Hex Nut	98150175	4
10.	5/8" Flat Washer	98250115	4
	Hardware Kit (Fasteners & Spacers)	081203	
	Custom Mounting Bracket Set (Brkts. & Hwd.)	0812	
	Installation Kit (Brackets, Rails & Hardware)	0824	

Tools Needed For Installation

1/2" Drill Motor
 1/8" & 1/16" Drill Bit
 1/2" Drill Bit
 3/4" Step Drill Bit

15/16" & 3/4" Socket
 1 1/8" Socket
 Torque Wrench
 Measuring Tape

1/2" Drive Impact Gun or 1/2"
 Drive Ratchet Wrench 3/4"
 Combination Wrench
 Felt Tipped Marker
 Hammer

Vehicle Preparation

After blocking the front wheels, place jack stands under the frame so that the rear of the truck is high enough to allow the rear wheels to drop. This will give easy access to the frame area in the rear wheel well.

Laying Out and Marking the Bed

Template method to mark bed:

1. Place the rear edge of the template 30-7/16" (8' bed), 26-3/8" (6' bed)
2. forward of the rear edge of the truck bed.
3. Center template in bed from left and right. Lineup the etched centerline with the centerline of the truck bed.
4. While standing on the template, use an 1/16" drill bit to mark the bed at each hole location (See figure 3 below).

Ask your distributor sales representative about hole pattern templates (P/N: 0899).

Layout method to mark bed:

Using the dimensions shown below (see figure 2 below), draw layout lines in the bed using a straight edge and marker or chalk line. At intersections of dashed lines, use a center punch to mark the bed.

Layout Method Fig. 2.

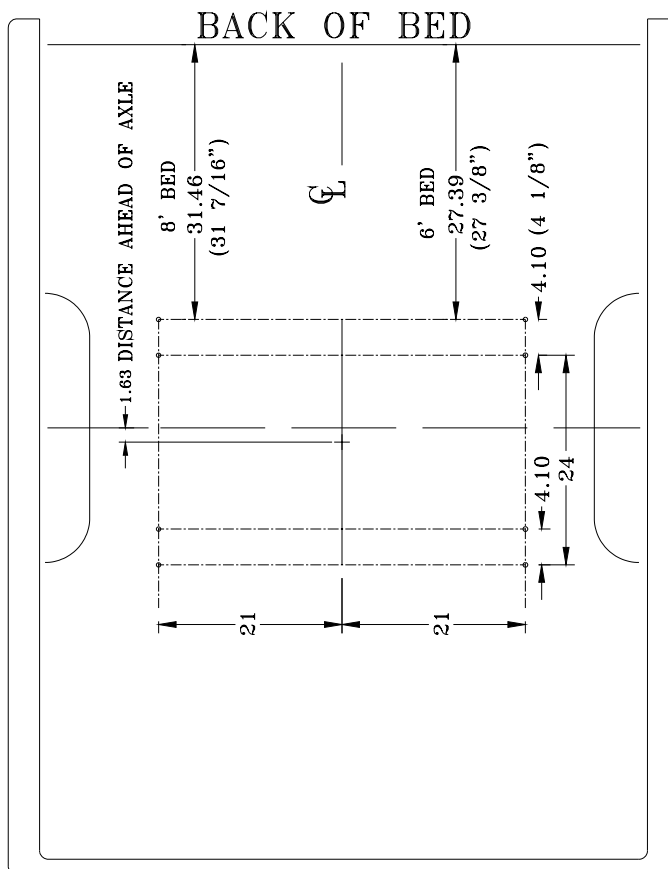

Template Method

Fig. 3.

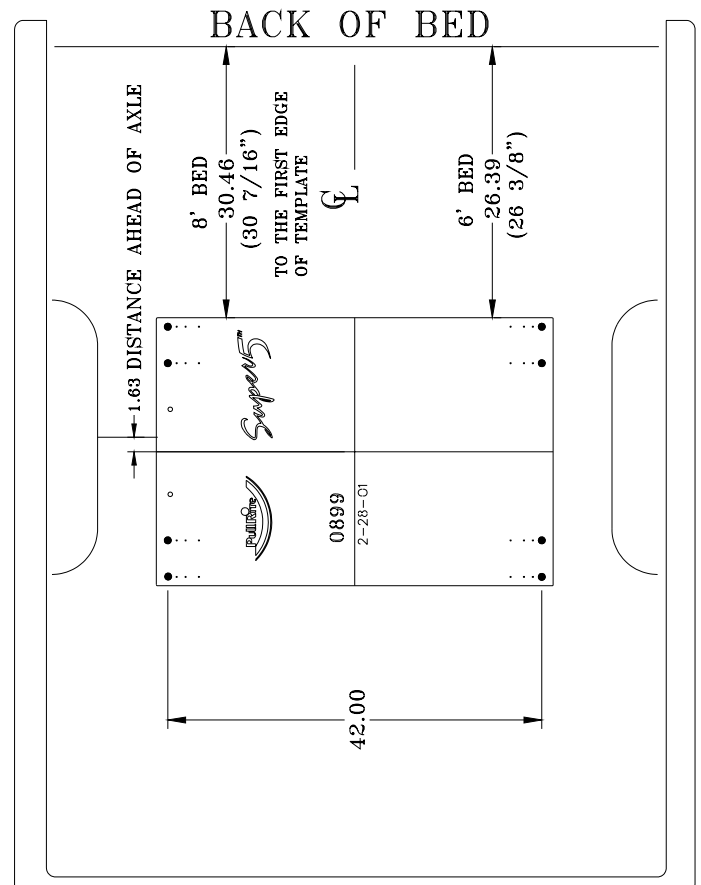

Installation Tips

To avoid drilling holes in error from out of tolerance bed to frame dimensions, mark the hole locations as lightly as possible if a center or transfer punched is used. Then use a very small diameter drill bit to drill one location on either side of bed. Place the Mounting Brackets against the frame to determine the correctness of the bed hole locations relative to the pre-punched holes in the Mounting Bracket (See figure below). Adjust the lay out or template pattern relative to the end of the bed, as necessary, to move the bed holes nearer the center of the mounting bracket holes.

Installers can keep a record of the adjustments that are found necessary to properly locate the bed holes. PullRite has performed numerous installations to develop these lay out dimensions, but encourages installers to satisfy themselves as to their accuracy. PullRite recommends using 3/4" holes through the bed to help accommodate tolerance variances that occur in the vehicle assembly. Experienced installers using PullRite custom brackets have been able to skip this step after several installations of a given model of truck.

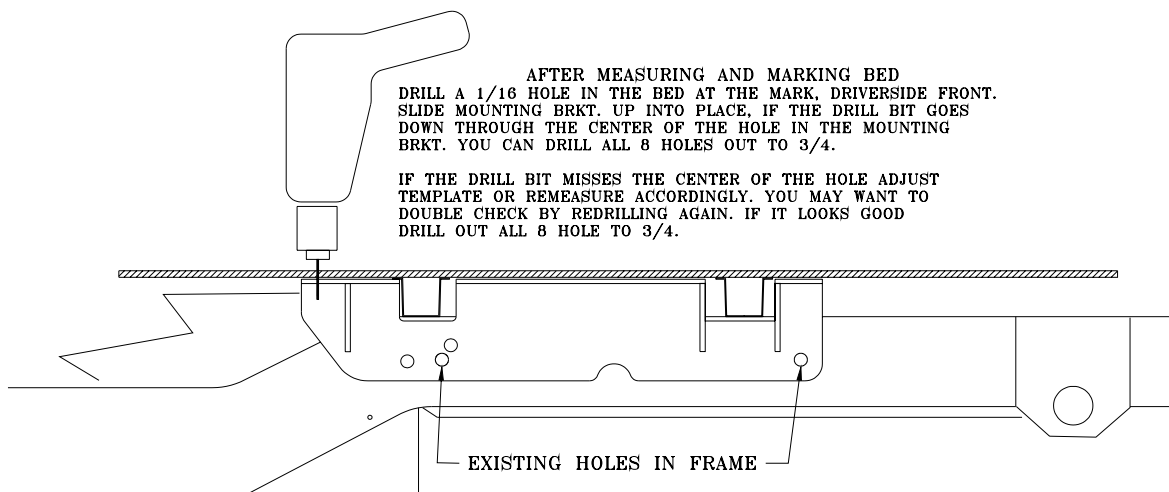

Drilling the Bed

1. Check all hole locations for any fuel lines or tanks and wiring that could become damaged in the drill process.
2. Once the bed hole pattern location is satisfactory, center punch all hole locations. If the template method is used, drill all eight indicated hole locations with an 1/16" drill bit using the template as a drill guide.
3. Drill all hole locations using a 3/4" drill bit. A step drill works best for drilling sheet metal.
4. Remove drill shavings from the bed and treat the raw edges of drill holes with a rust inhibitor.

Hitch Assembly

Hitch Assembly for 20,500#:

If the hitch type to be installed is a 20,500# (Part #0800), there is no assembly required except to attach the Base Rails to the base feet of the hitch Base using the four 1/2" Base Rail Pins and four #3 Pin Clips (See exploded drawing on page 2).

This hitch has four height settings and should be adjusted according to the directions found in the Operators Instructions found in the same box as the hitch. Be sure to torque all four 1/2" x 1 1/2" Bolts to 75 foot pounds.

Hitch Assembly for 15,500#:

If the hitch type to be installed is a 15,500# (Part #1200), it will be necessary to assemble the hitch first. Refer to page 3 and the exploded view of this hitch and the parts list below the drawing and follow these steps:

1. Arrange the Base Rails parallel to each other and attach the Base Sides using the four 1/2" Base Rail Pins and four #3 Pin Clips.
2. Remove the 3/4" x 7" Pivot Bolt from the Rocker Arm and Crossmember.
3. The Rocker Arm is shipped upside down in the Crossmember for better packaging and will need to be removed and reinstalled right side up in the Crossmember as shown in the exploded view drawing on page 3. Tighten the 3/4" x 7" Pivot Bolt only enough to flatten the 3/4" Lock Washer or enough so that the Rocker Arm will rotate stiffly. Lubricate the 3/4" Pivot Bolt with heavy grease before installing.
4. Fasten the Crossmember and Base Sides together using six each of the 1/2"-13 x 1 1/2" Bolts, 1/2" Lock Washers and 1/2"-13 Hex Nuts, tighten bolts to 75 foot pounds. This hitch has four height settings and should be adjusted according to the directions found in the Operators Instructions found in the same box as the hitch.
5. Fasten the Fifth Wheel Plate in the Rocker Arm using two each of the 1/2" Clevis Pins and #3 Pin Clips after installing the Release Handle and Main Spring as shown in Plate

Hitch Installation

(read instructions once completely before beginning actual installation)

1. Install Bed Channel Spacers directly above the mounting holes drilled in the bed (See the figure on page 8).
2. Set the hitch assembly in the bed so that the first set of square holes from the end of the Base Rails line up with the holes drilled in the bed.
3. Referring to the figure on page 8 and the exploded view on page 4, insert the six 1/2" - 13 x 2" Carriage Bolts through the Base Rail, Bed Spacers and bed.
4. Referring to the figure on page 8 and the exploded view on page 4, fit the Mounting Brackets over the Carriage Bolts and insert the 5/8"-11 x 1 1/2" Hex Bolts through the hole in the Mounting Bracket and the frame. Fasten the Mounting Bracket to the frame with 5/8" Flat Washers, 5/8" Lock Washers, and 5/8"-11 Hex Nuts. Torque all 5/8" fasteners to 150 foot pounds. The forward hole location varies per year of truck, use only the hole that matches, no drilling required.
5. Using the square hole in the Base Rail as a guide and using a 1/2" drill bit, drill a hole in the bottom of the cross sill located at the rear of the Mounting Bracket and insert the two 1/2"-13 x 5" Carriage Bolts (See the figure on page 4).
6. Using eight 1/2"- 13 Flanged Nuts provided, fasten all of the carriage bolts and torque

Installation Tips

Make sure that all of the Carriage Bolts are hanging straight down. If they are not, remove the Carriage Bolt and run a 1/2" drill bit through the hole so that they will. Bolts that do not hang straight may cause the Base Rails to shift and, in turn, make the removal and reattachment of the base more difficult.

Caution: As there is a void in the cross sill, when tightening the 5" Carriage Bolt, do not tighten to 75 foot pounds if the bed and Base Rail begins to "pull down".

General Comments

First installations of any product usually take longer than if they were practiced. Keeping a record of measurement adjustments for each vehicle, make, and model will speed future installations and aid others who are training to install hitches. For installers who are interested in a hole pattern template, contact your PullRite distributor sales representative. If you have any installation questions, contact PullRite customer service at 800/443-2307.

