



Super 5th Towing Solutions

INSTALLATION INSTRUCTIONS

SPECIFICATIONS:

25,500 Super 5th, (Part #0503)
 Gross Trailer Weight (Maximum).....25,500 lbs.
 Vertical Load Weight (Max. Pin Weight).....6,375 lbs.

FOR USE WITH
2001–2008 CHEVROLET/GMC HEAVY DUTY CUSTOM
MOUNTING BRACKET KIT (Part # 0527)

Introduction

The following steps provide several pages of general instruction for the installation of the **25,500# (part number 0503) SUPER 5TH** towing system. Should you have any questions, please call the factory at (574) 259-1520 for installation assistance.

Index

Page

Introduction	1
Parts List For Hitch	2
Parts List For Custom Mounting & Tools Needed for Installation	3
Super 5th Preparation, Vehicle Preparation & Bracket Installation	4
Laying Out and Marking the Bed	5
Drilling the Bed & Hitch Installation & Tips	6
Installation Tips & General Comments	7

Parts List For 25,500 Super 5th Hitch

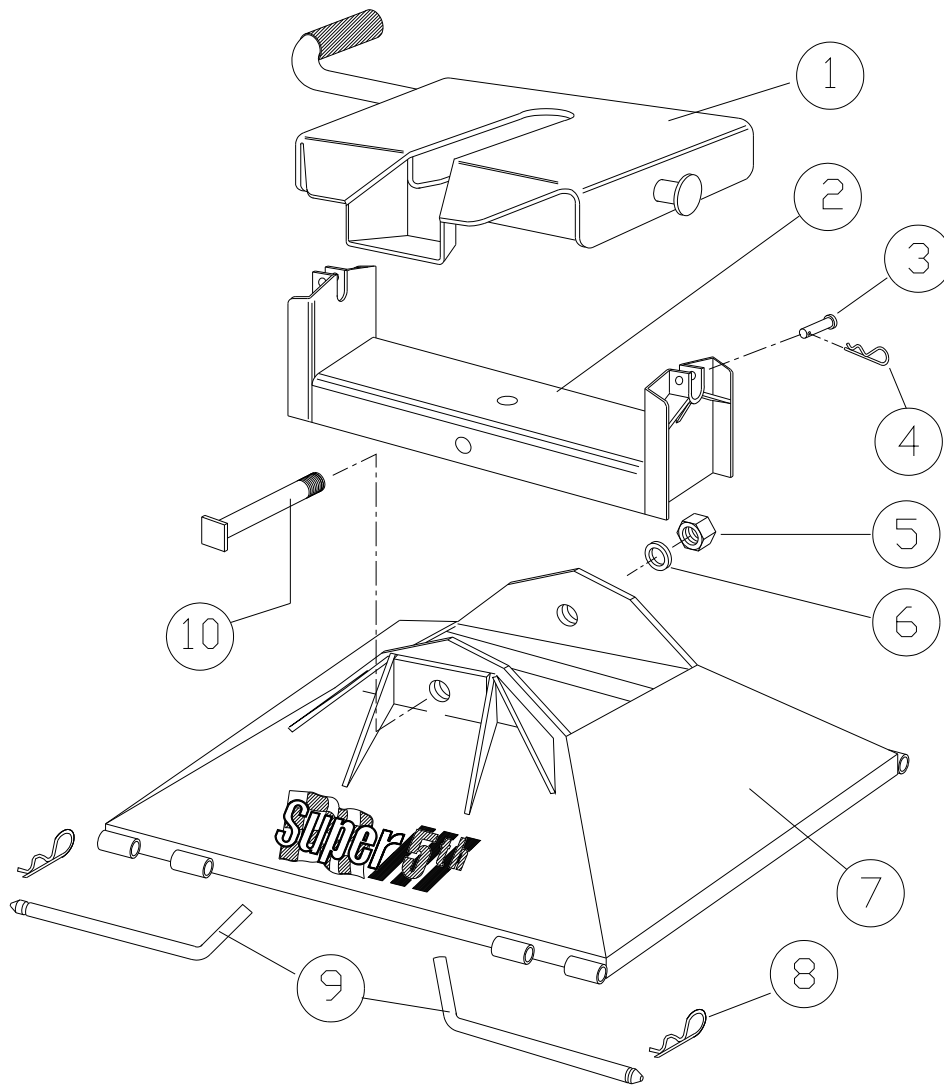

Ref.	Description	Part #	Qty.
1)	Plate	3601	1
2)	Rocker Arm	050403	1
3)	1/2" Clevis Pin	98410111	2
4)	#3 Pin Clip	98410127	2
5)	1" -8 Hex Nut	98150120	1
6)	1" Lock Washer	98200115	1
7)	Base Pedestal	050402	1
8)	#9 Pin Clip	98410143	4
9)	3/4" Rd. Base Rail Hinge Pins	05010601	4
10)	1" -8 x 7-1/2" HHCS Pivot Bolt	140501	1

Parts List For 25,500 Super 5th Custom Mounting Bracket Kit Part # 0527

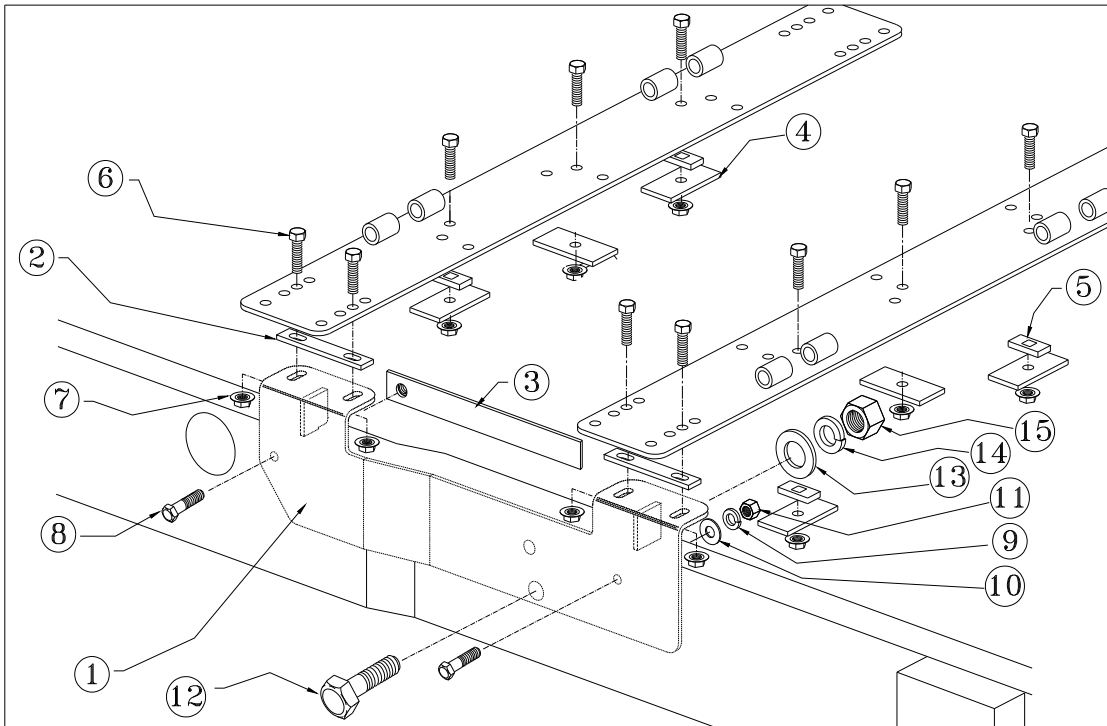

Ref.	Description	Part #	Qty.
1)	1 set Chevy HD Custom Brkts	0510	1
2)	5/16" x 1" Bottom Bed Shim (two hole)	05100301	4
3)	Front Hole Nut Plate	051004	2
4)	Center Hole Back-up Plate	05070205	6
5)	5/16" x 1" Bottom Bed Shim (one hole)	05100302	4
6)	1/2" x 2" HHCS Mounting Bolts	98010175	14
7)	1/2" - 13 Flange Nut	98150201	14
8)	1/2" x 1-1/2" HHCS Frame Bolts	98010167	4
9)	1/2" Lock Washer	98200142	4
10)	1/2" Flat Washer	98200145	2
11)	1/2" - 13 Hex Nuts	98150153	2
12)	1" - 8 HHCS Bolt	98010109	2
13)	1" Flat Washer	98250100	2
14)	1" Lock Washer	98200115	2
15)	1"-8 Hex Nut	98150120	2

Tools Needed For Installation

1/2" Drill Motor
1/16" Drill Bit
1/2" Drill Bit
3/4" Step Drill Bit

3/4" Socket
1 1/8" Socket
Torque Wrench
Measuring Tape

1/2" Drive Impact Gun or 1/2"
Drive Ratchet Wrench 3/4"
Combination Wrench
Felt Tipped Marker
Hammer

Super 5th Preparation

Before the Super 5th is used, the following preparations should be followed:

1. A zerk grease fitting is assessable through a hole located on the top side of the Rocker Arm. Three to five pumps with a grease gun, using a quality axle type grease, should be adequate lubrication for the Rocker Arm Pivot Bolt. All remaining moving parts should be coated with light machine oil.
2. The Plate and it's moving parts should be lubricated with a light lubricant such as WD-40, 3-in-1 oil, or Silicone Spray Lubricant, before each trip or as needed. Be sure the Plate is free of dirt and old oil buildup.

Vehicle Preparation

After blocking the front wheels, place jack stands under the frame so that the rear of the truck is high enough to allow the rear wheels to drop. This will give easy access to the frame area in the rear wheel well.

Bracket Installation

Drivers Side

Directly above the wheel, there are two 1/4" holes with plastic fasteners holding a wire loom to the frame of the truck. Remove the plastic fastener in the rear 1/4" hole. Enlarge the 1/4" hole to a 1/2" hole.

Place the bracket onto the side of the frame, positioning the flange of the bracket over the top of the truck frame so that it rests flush with the side of the frame. Using the slotted 1" hole located above the wheel as a locator point, slide the bracket to align the rear of the predrilled 1/2" hole in the bracket with the rear of the slotted 1" hole. Another predrilled 1/2" hole in the bracket should line up with the enlarged 1/4" hole you had just drilled.

Clamp the bracket into place. Using the forward-most predrilled hole in the bracket as a guide, drill a 1/2" hole in the frame. Place bolts into the holes, and finger tighten.

Passenger Side

Place the bracket onto the side of the frame, positioning the flange of the bracket over the top of the truck frame so that it rests flush with the side of the frame. Using the slotted 1" hole located above the wheel as a locator point, slide the bracket to align the rear of the predrilled 1" hole in the bracket with the rear of the slotted 1" hole.

Clamp the bracket into place. Using the forward most predrilled hole in the bracket as a guide, drill a 1/2" hole in the frame. Also drill a 1/2" hole in the frame using the rear most predrilled hole as a guide. Place bolts into the holes, and finger tighten.

Laying Out and Marking the Bed

Template method to mark bed:

1. Place the rear edge of the template 29-29/32" forward of the rear edge of the truck bed.
2. Center template in bed from left and right. Lineup the etched centerline with the centerline of the truck bed.
3. While standing on the template, use a 1/8" drill bit to lightly mark the bed at each hole location (See figure below).

Ask your distributor sales representative about hole pattern templates (P/N: 0589).

Layout method to mark bed:

Using the dimensions shown below, draw layout lines in the bed using a straight edge and marker or chalk line. At intersections of dashed lines, use a center punch to mark the bed.

Layout Method 8' Bed

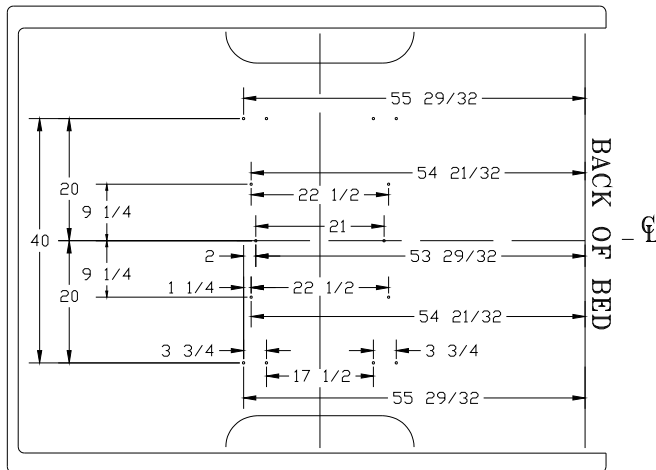

Template Method 8' Bed

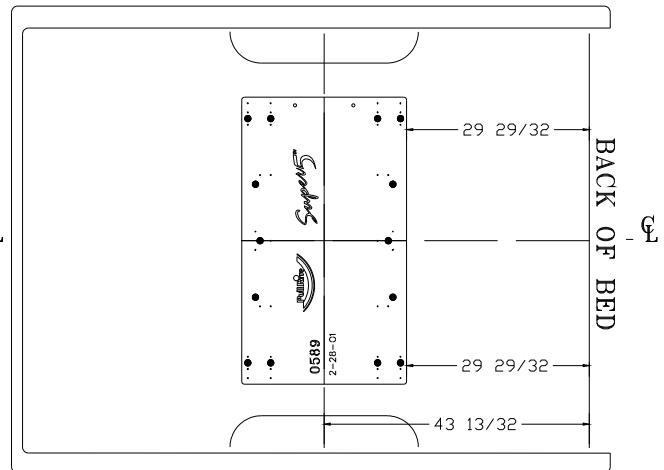

NOTE: Even though the 0527 Mounting Kit will fit the short bed Chevrolet / GMC trucks, PullRite does not recommend the use of standard 5th wheel hitches in short bed trucks. PullRite produces the SuperGlide 5th wheel hitch that automatically slides to the rear of the truck as turns are made allowing the trailer to pass the cab with out contact.

Layout Method 6' Bed

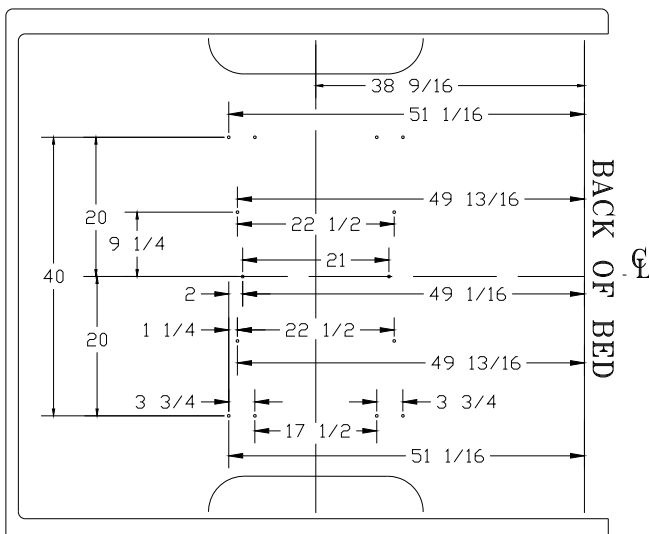

Template Method 6' Bed

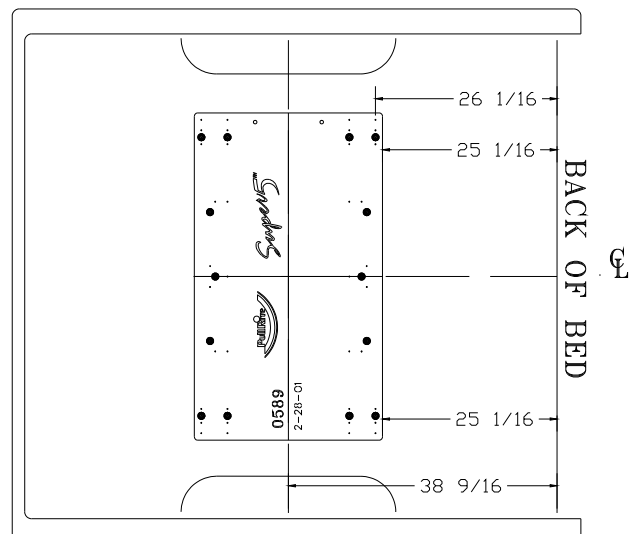

Installation Tips

To avoid drilling holes in error from out of tolerance bed to frame dimensions, mark the hole locations as lightly as possible. Then use a very small diameter drill bit to drill one location on either side of bed. Determine the correctness of the bed hole locations relative to the pre-punched holes in the horizontal flange of the mounting bracket. Adjust the lay out or template pattern relative to the end of the bed, as necessary, to move the bed holes nearer the center of the mounting bracket holes.

Installers can keep a record of the adjustments that are found necessary to properly locate the bed holes. PullRite has performed numerous installations to develop these lay out dimensions, but encourages installers to satisfy themselves as to their accuracy. PullRite recommends using 3/4" holes through the bed to help accommodate tolerance variances that occur in the vehicle assembly. Experienced installers using PullRite custom brackets have been able to skip this step after several installations of a given model of truck.

Drilling the Bed

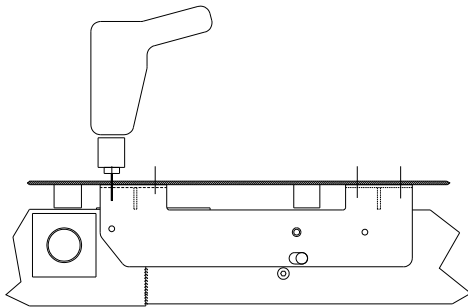

1. Remove bracket from frame.
2. Check all hole locations for any fuel lines or tanks and wiring that could become damaged in the drill process.
3. Once the bed hole pattern location is satisfactory, center punch all the hole locations.
4. Drill all hole locations using a 3/4" drill bit. A step drill works best for drilling sheet metal.
5. Remove drill shavings from the bed and treat the raw edges of the drill holes with a rust inhibitor.

Hitch Installation

(read instructions once completely before beginning actual installation)

1. Attach the **Base Pedestal** (PN: 050402) to the **Base Rail** (PN: 050404) loops using the four **3/4" Base Rail Hinge Pins** (PN: 050110) and four **#9 Pin Clips** (PN: 98410143).
2. Install **Bed Shims** (PN: 05070301) directly above the mounting holes drilled in the bed. (see figure next page)
3. Set the hitch assembly in the bed so that the first set of holes from the end of the **Base Rails** (PN: 050404) line up with the holes drilled in the bed.
4. Referring to the upper left figure on page 7, use a suitable tool to pry up each of the Flange Nut Retaining Tabs then insert a **1/2"-13 Flange Nut** (PN: 98150201) in the slot as shown. Push the Retaining Tab back into place.
5. Referring to the above figure, the exploded view drawing on page 3 and the figures on page 7, fit the **Mounting Brackets** (PN: 0510) over the frame and insert four of the **1/2" x 1-1/2" HHCS** (PN: 98010167) through the holes in the **Mounting Bracket** (PN: 0510) and the frame. Fasten the **Mounting Bracket** (PN: 0510) to the frame with **1/2" Lock Washers** (PN: 98200142) and **1/2" - 13 Hex Nuts** (PN: 98150153). Also fasten with two of the **1"-8 HHCS** (PN: 98010109), **1" Flat Washer** (PN: 98250100), **1" Lock Washer** (PN: 98200115) and **1"-8 Hex Nut** (PN: 98150120). Leave all these fasteners finger tight.
6. Referring to the exploded view drawing on page 3 and the figures on page 7, fasten the **Base Rails** (PN: 050404) to the **Mounting Bracket** (PN: 0510) with eight **1/2"-13 x 2" HHCS** (PN: 98010175) after sliding each **1/2"-13 Flange Nut** (PN: 98150201) directly under each holes in the **Base Rails** (PN: 050404). Tighten these bolts to 75 foot pounds.
7. Remove two of the **3/4" Base Rail Hinge Pins** (PN: 050110) then lift that edge of the **Base Pedestal** (PN: 050402) to expose the center of the **Base Rails** (PN: 050404). Referring to the upper right hand figures on page 7, fasten the center portion of the **Base Rails** (PN: 050404) to the bed using six, **1/2"-13 x 2" HHCS**, **1/2"-13 Flange Nuts** (PN: 98150201), **Bed Shims** (PN: 05070301) and **Back-up Plates** (PN: 05070205) provided, torque all 1/2" bolts to 75 foot pounds and 1" bolts to 200 foot pounds.

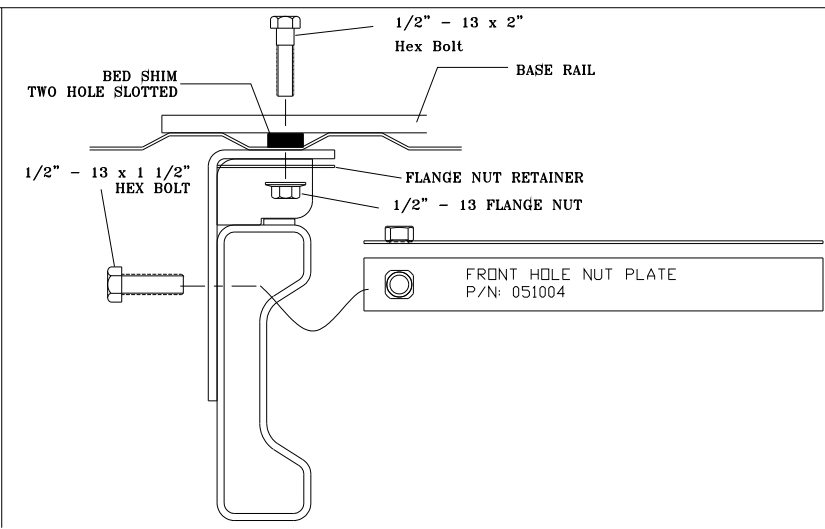
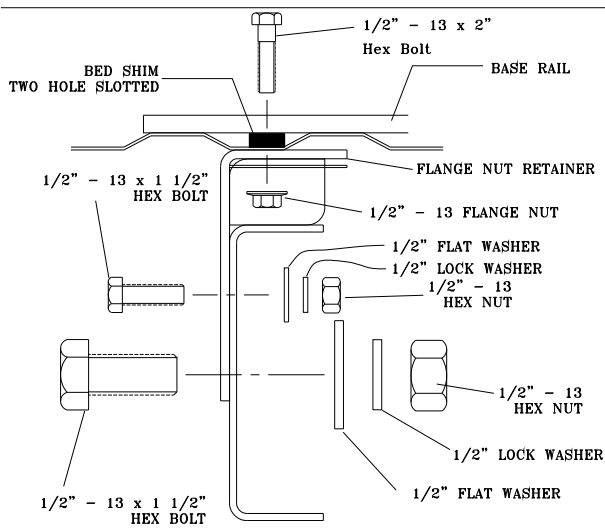
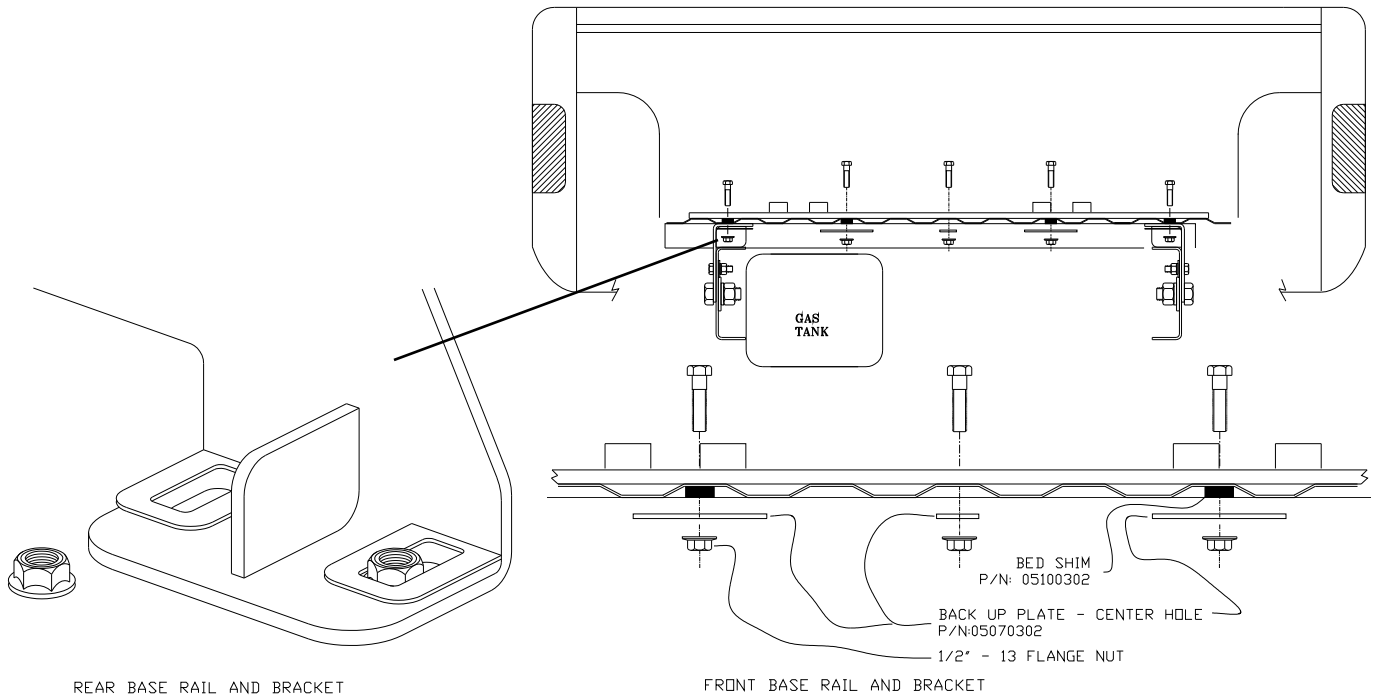

Installation Tips

Make sure that all of the Hex Bolts are hanging straight down. If they are not, remove the Hex Bolt and run a 1/2" drill bit through the hole so that they will. Bolts that do not hang straight may cause the Base Rails to shift and, in turn, make the removal and reattachment of the base more difficult.

In order to place the Flange Nuts for locations that are hard to reach, place a spray adhesive on the Bottom Bed Shim, Center Hole Back-up Plate, and Flange Nut. Then, position them in place. The actual placement of these pieces could be difficult to reach. In order to do this, a tool can be fashioned from a piece of material with the approximate dimensions of 1/4" x 2" x 20", with a 7/8" hole cut about 2 to 3 inches from one end. Place the nut, which is now attached to the backup plate and bed shim with spray adhesive, in the 7/8" hole and position it through the wheel well. Spray adhesive can be applied to underside of bed as well.

General Comments

First installations of any product usually take longer than if they were practiced. Keeping a record of measurement adjustments for each vehicle, make, and model will speed future installations and aid others who are training to install hitches. For installers who are interested in a hole pattern template, contact your PullRite distributor sales representative. If you have any installation questions, contact PullRite customer service at 800/443-2307.