



Super 5th Towing Solutions

INSTALLATION INSTRUCTIONS

SPECIFICATIONS:

25,500 Super 5th, (Part #0503)

Gross Trailer Weight (Maximum).....25,500 lbs.

Vertical Load Weight (Max. Pin Weight).....6,375 lbs.

FOR USE WITH

**1995-2002 (except '02 1/2 ton) DODGE HEAVY DUTY CUSTOM
MOUNTING BRACKETS (Part # 0511/0524)**

Revision 1.02, Date 5/24/01

Introduction

The following steps provide several pages of general instruction for the installation of the **25,500# (part number 0503) SUPER 5TH** towing system. Should you have any questions, please call the factory at (800) 443-2307 for installation assistance. The **SUPER 5TH** towing systems have been tested to VESC-19 specifications.

Index

Page

Introduction	1
Parts List For Hitch	2
Parts List For Custom Mounting Brkts & Tools Needed for Installation	3
Super 5th Preparation, Vehicle Preparation & Laying Out and Marking the Bed	4
Installation Tip & Drilling the Bed	5
Hitch Assembly & Hitch Installation	6
Installation Tips & General Comments	7

Parts List For 25,500 Super 5th Hitch

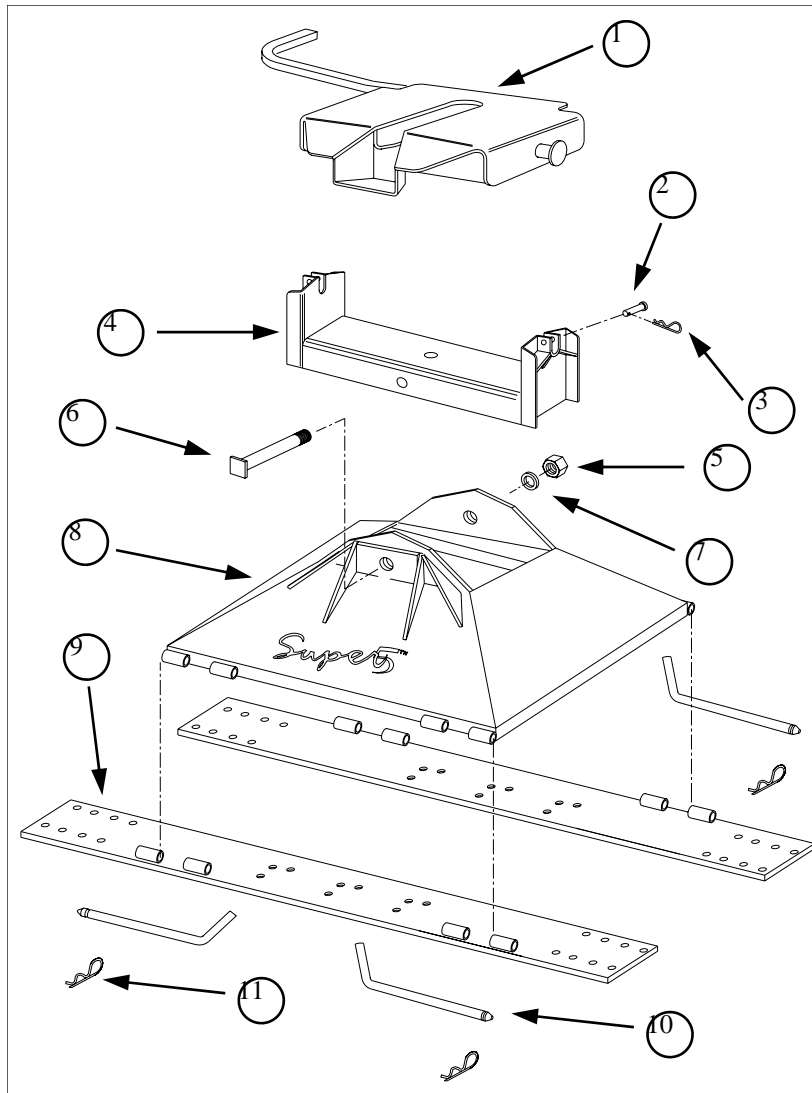

Ref.	Description	Part #	Qty.
1)	Plate	3601	1
2)	1/2" Clevis Pin	98410111	2
3)	#3 Pin Clip	98410127	2
4)	Rocker Arm	050403	1
5)	1" -8 Hex Nut	98150120	1
6)	1" -8 x 7-1/2" HHCS Pivot Bolt	140501	1
7)	1" Lock Washer	98200115	1
8)	Base Pedestal	050402	1
9)	Base Rails	050404	2
10)	3/4" Rd. Base Rail Hinge Pins	05010601	4
11)	#9 Pin Clip	98410143	4

Parts List For 25,500 Super 5th Custom Mounting Brackets

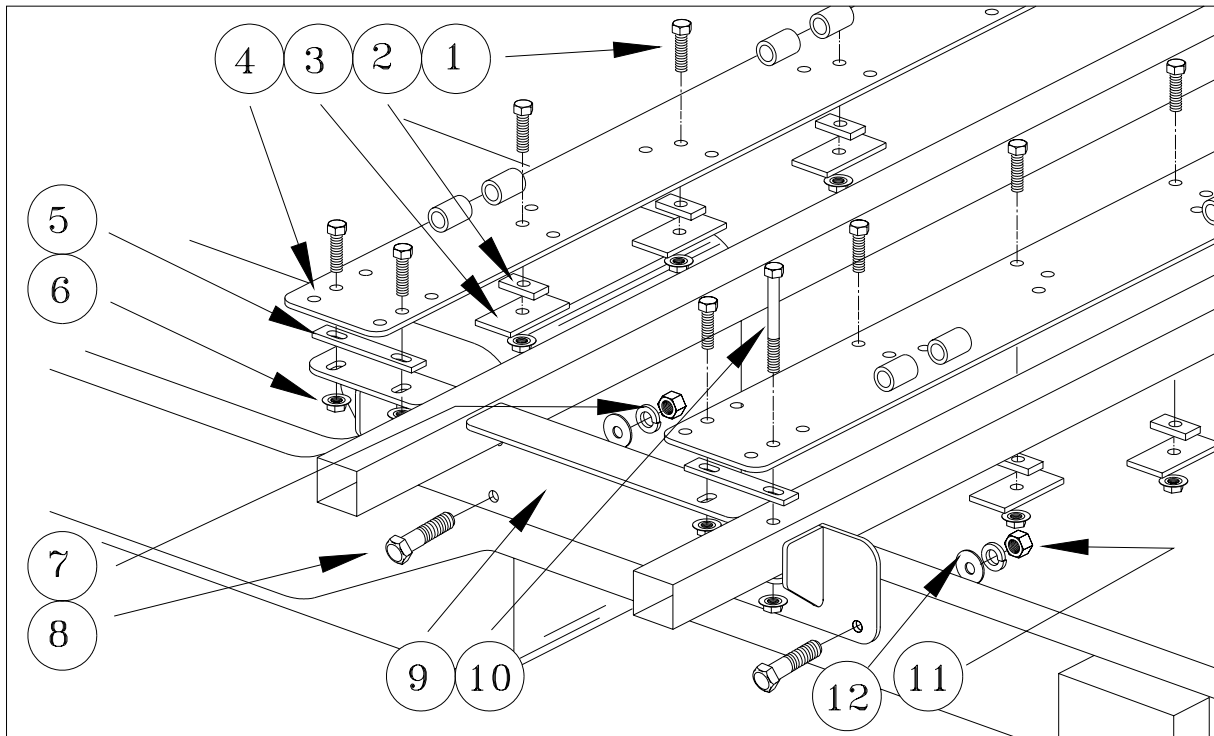

Ref.	Description	Part #	Qty.
1)	1/2" x 2" HHCS Mounting Bolts	98010175	12
2)	1/4" x 1" Bottom Bed Shim (one hole)	08070003	6
3)	Center Hole Back-up Plate	05070205	6
4)	Base Rails	050404	2
5)	1/4" x 1" Bottom Bed Shim (two hole)	05070301	4
6)	1/2" - 13 Flange Nut	98150201	14
7)	5/8" Lock Washer	98200133	4
8)	5/8" x 1-1/2" HHCS Frame Bolts	98010231	4
9)	1 set Dodge HD Custom Brkts	0511	1 set
10)	1/2" x 5" HHCS Mounting Bolts	98010199	2
11)	5/8" - 13 Hex Nuts	98150175	4
12)	5/8" Flat Washer	98250115	4

Hardware Kit (Fasteners, Spacers & Backing Plates) 051103

Installation Kit (Brkt., Rails & Hardware) 0524

Tools Needed For Installation

1/2" Drill Motor
 1/16" Drill Bit
 1/2" Drill Bit
 3/4" Step Drill Bit

3/4" Socket
 1 1/8" Socket
 Torque Wrench
 Measuring Tape

1/2" Drive Impact Gun or 1/2"
 Drive Ratchet Wrench 3/4"
 Combination Wrench
 Felt Tipped Marker
 Hammer

Super 5th Preparation

Before the Super 5th is used, the following preparations should be followed:

1. A zerk grease fitting is located on the bottom side of the rocker arm, accessible after installation by tilting the base forward or back, rotating on either set of 3/4" round base rail hinge pins. Three to five pumps with a grease gun, using an axle type grease, should be adequate lubrication for the grease zerk fitting. All remaining moving parts should be coated with light machine oil.
2. The Plate and it's moving parts should be lubricated with a light lubricant such as WD-40, 3-in-1 oil, or Silicone Spray Lubricant, before each trip or as needed. Be sure the Plate is free of dirt and old oil buildup.

Vehicle Preparation

After blocking the front wheels, place jack stands under the frame so that the rear of the truck is high enough to allow the rear wheels to drop. This will give easy access to the frame area in the rear wheel well.

Remove the spare tire and loosen the heat shield. This will allow easy access to the underside of the truck bed.

Laying Out and Marking the Bed

Template method to mark bed:

1. Place the rear edge of the template 32-27/32" forward of the rear edge of the truck bed.
2. Center template in bed from left and right. Lineup the etched centerline with the centerline of the truck bed.
3. While standing on the template, use a 3/8" transfer punch to mark the bed at each hole location (See figure below).

Ask your distributor sales representative about hole pattern templates (P/N: 0589).

Layout method to mark bed:

Using the dimensions shown below, draw layout lines in the bed using a straight edge and marker or chalk line. At intersections of dashed lines, use a center punch to mark the bed.

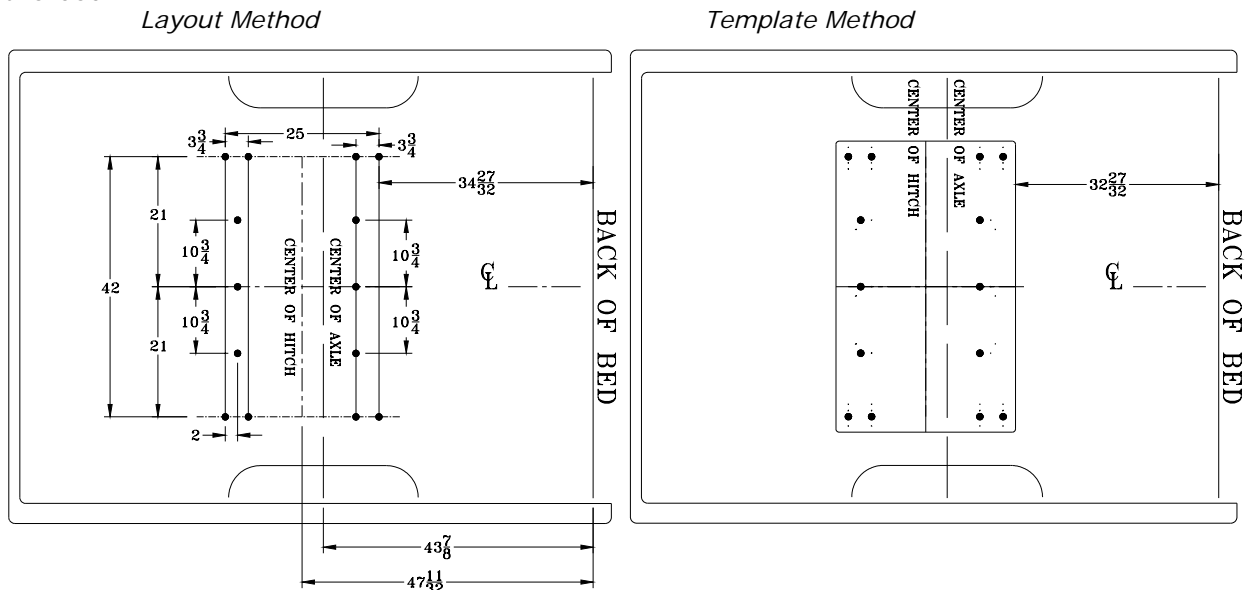

Installation Tips

To avoid drilling holes in error from out of tolerance bed to frame dimensions. Use a very small diameter drill bit to drill one location on either side of bed. Determine the correctness of the bed hole locations relative to the pre-punched holes in the mounting bracket (See figure below). Adjust the lay out or template pattern relative to the end of the bed, as necessary, to move the bed holes nearer the center of the mounting bracket holes.

Installers can keep a record of the adjustments that are found necessary to properly locate the bed holes. PullRite has performed numerous installations to develop these lay out dimensions, but encourages installers to satisfy themselves as to their accuracy. PullRite recommends using 3/4" holes through the bed to help accommodate tolerance variances that occur in the vehicle assembly. Experienced installers using PullRite custom brackets have been able to skip this step after several installations of a given model of truck.

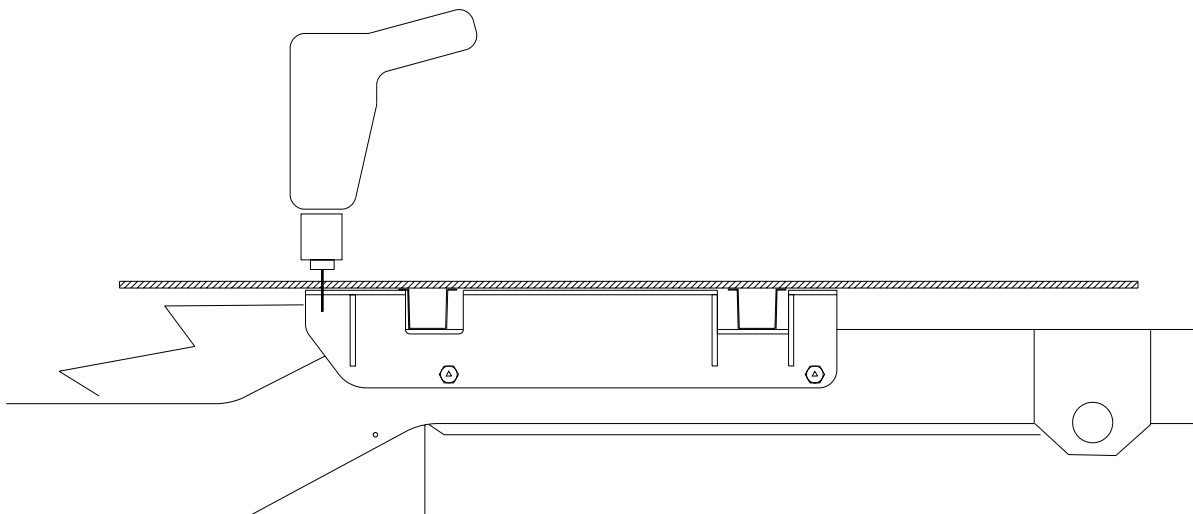

Drilling the Bed

1. Verify that mounting brackets are removed.
2. Check all bed hole locations for any fuel lines or tanks and wiring that could become damaged in the drill process.
3. Proceed only after bed hole pattern location are satisfactory, and all hole locations are drilled with a 1/16" drill. This will reduce complications in installation.
4. Drill all hole locations using a 3/4" drill bit. A step drill works best for drilling sheet metal.
5. Remove drill shavings from the bed and treat the raw edges of the drill holes with a rust inhibitor.

Hitch Assembly

There is no assembly required except to attach the Base Rails to the hitch Base using the four 3/4" Base Rail Pins and four #3 Pin Clips.

Be sure to torque all 1/2" Bolts to 75 foot pounds and 5/8" Bolts to 150 foot pounds.

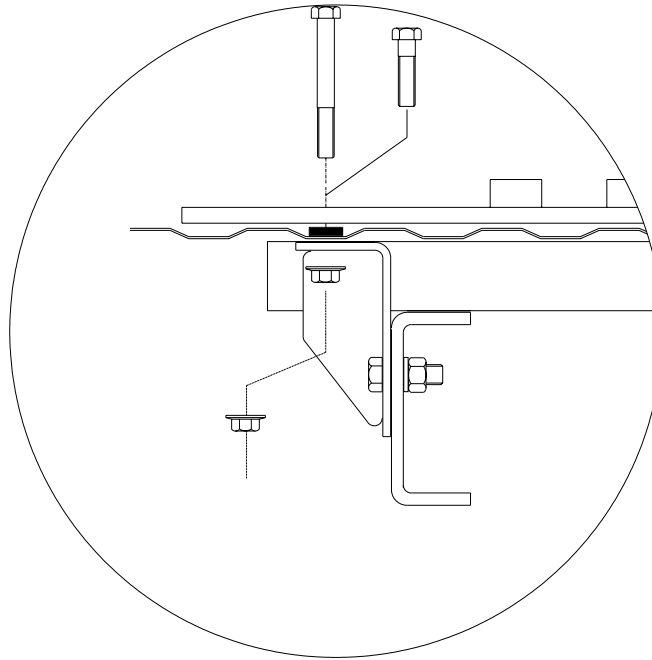

Hitch Installation

(read instructions once completely before beginning actual installation)

1. Install Bed Channel Spacers directly above the mounting holes drilled in the bed (See the figure above and next page).
2. Set the hitch assembly in the bed so that the second set of holes from the end of the Base Rails line up with the holes drilled in the bed.
3. Referring to the figure on page 7 and the exploded view on page 4, insert the twelve 1/2" x 2" Mounting Bolts through the Base Rail, Bed Spacers and bed, excluding the rear-most outside holes.
4. Referring to the figure on page 7 and the exploded view on page 4, fit the Mounting Brackets over the Mounting Bolts and insert the 5/8" x 1 1/2" Hex Bolts through the hole in the Mounting Bracket and the frame. Fasten the Mounting Bracket to the frame with 5/8" Flat Washers, 5/8" Lock Washers, and 5/8" Hex Nuts. Torque all 5/8" fasteners to 150 foot pounds.
5. Using the hole in the Base Rail as a guide and using a 1/2" drill bit, drill a hole in the bottom of the cross sill located at the rear of the Mounting Bracket and insert the two 1/2" x 5" Mounting Bolts (See the figure on page 3).
6. Using eight 1/2" Flanged Nuts provided, fasten all of the Mounting Bolts and torque to 75 foot pounds.

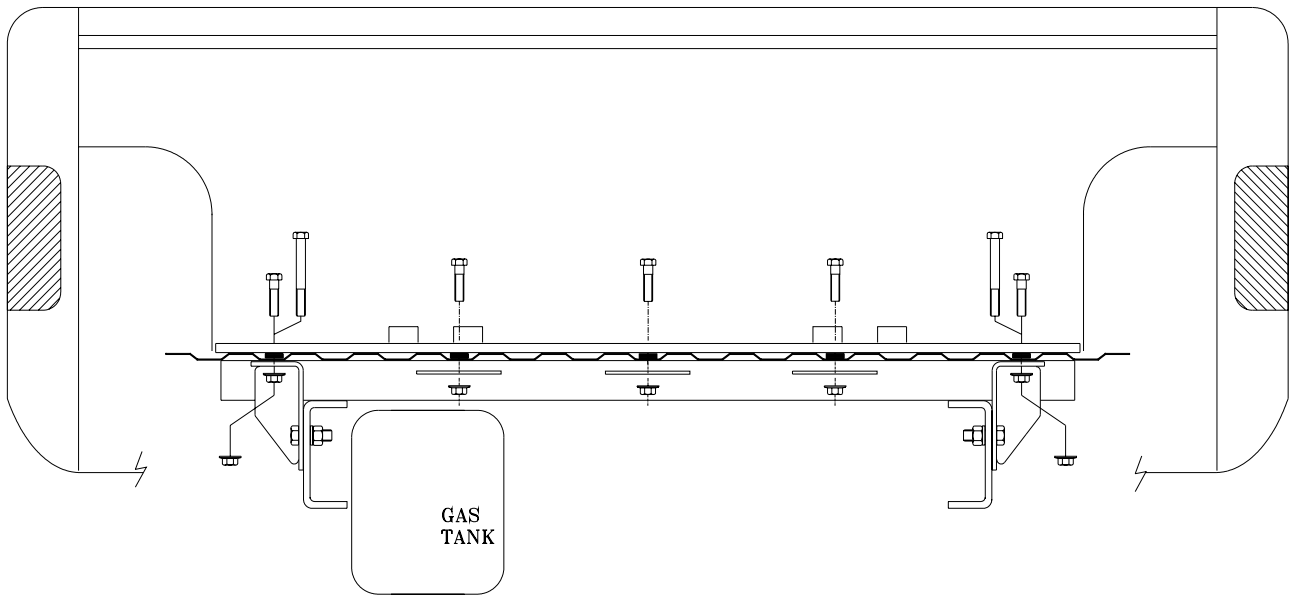

Installation Tips

Make sure that all of the Hex Bolts are hanging straight down. If they are not, remove the Hex Bolt and run a 1/2" drill bit through the hole so that they will. Bolts that do not hang straight may cause the Base Rails to shift and, in turn, make the removal and reattachment of the base more difficult.

In order to place the Flange Nuts for locations that are hard to reach, place a spray adhesive on the Bottom Bed Shim, Center Hole Back-up Plate, and Flange Nut. Then, position them in place. The actual placement of these pieces could be difficult to reach. In order to do this, a tool can be fashioned from a piece of material with the approximate dimensions of 1/4" x 2" x 20", with a 7/8" hole cut about 2 to 3 inches from one end. Place the nut, which is now attached to the backup plate and bed shim with spray adhesive, in the 7/8" hole and position it through the wheel well. Spray adhesive can be applied to underside of bed as well.

Caution: As there is a void in the cross sill, when tightening the 5" Carriage Bolt, do not tighten to 75 foot pounds if the bed and Base Rail begins to "pull down".

General Comments

First installations of any product usually take longer than if they were practiced. Keeping a record of measurement adjustments for each vehicle, make, and model will speed future installations and aid others who are training to install hitches. For installers who are interested in a hole pattern template, contact your PullRite distributor sales representative. If you have any installation questions, contact PullRite customer service at 800/443-2307.