



Super 5th Towing Solutions

INSTALLATION INSTRUCTIONS

SPECIFICATIONS:

25,500 Super 5th, (Part #0503)
 Gross Trailer Weight (Maximum).....25,500 lbs.
 Vertical Load Weight (Max. Pin Weight).....6,375 lbs.

FOR USE WITH

UNIVERSAL MOUNTING BRACKETS (Part # 0512/0520)

Revision 1.01, Date 5/29/01

Introduction

The following steps provide several pages of general instruction for the installation of the **25,500# (part number 0503) SUPER 5TH** towing system. Should you have any questions, please call the factory at (800) 443-2307 for installation assistance. The **SUPER 5TH** towing systems have been tested to VESC-19 specifications.

Index

Page

Introduction	1
Parts List For Hitch	2
Parts List For Universal Mounting Brkts & Tools Needed for Installation	3
Super 5th Preparation, Vehicle Preparation & General Installation Instructions	4-7

Parts List For 25,500 Super 5th Hitch

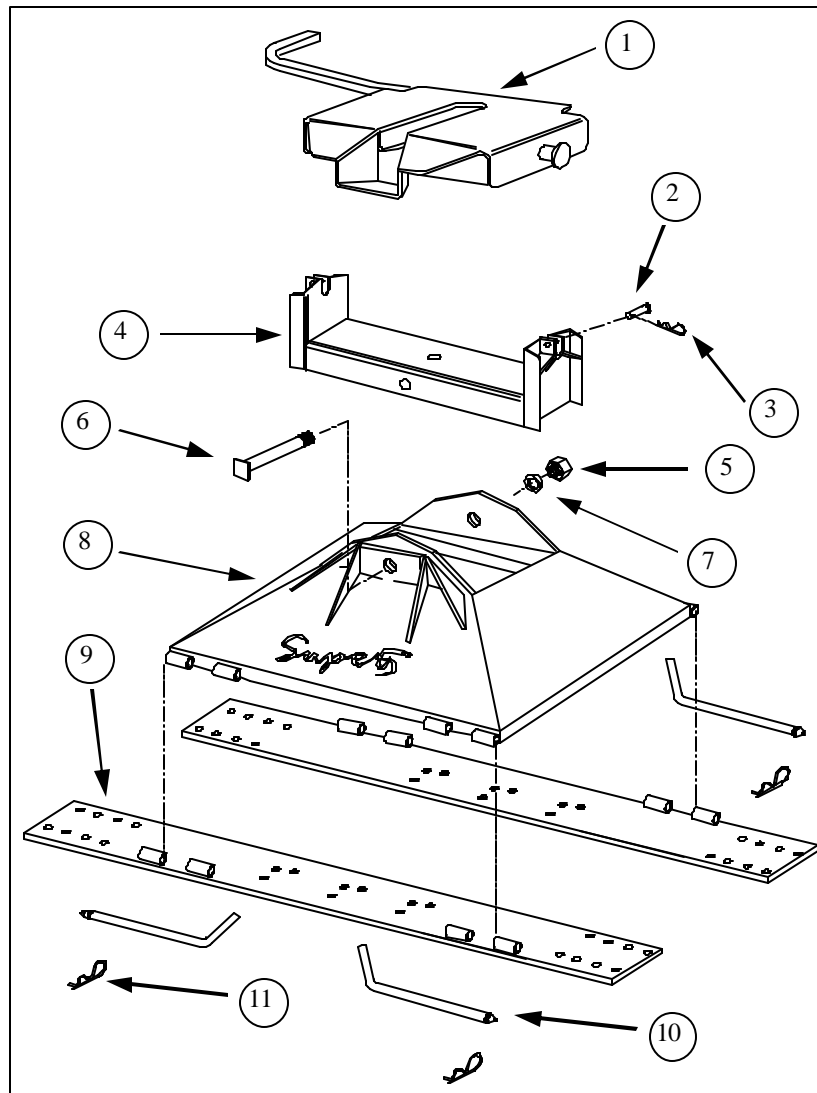

Ref.	Description	Part #	Qty.
1	Plate	1201	1
2	1/2" Clevis Pin	98410111	2
3	#3 Pin Clip	98410127	2
4	Rocker Arm	050403	1
5	1" -8 Hex Nut	98150120	1
6	1" -8 x 7-1/2" HHCS Pivot Bolt	140501	1
7	1" Lock Washer	98200115	1
8	Base Pedestal	050402	1
9	Base Rails	050404	2
10	3/4" Rd. Base Rail Hinge Pins	05010601	4
11	#9 Pin Clip	98410143	4

Parts List For 25,500 Super 5th Universal Mounting Brackets

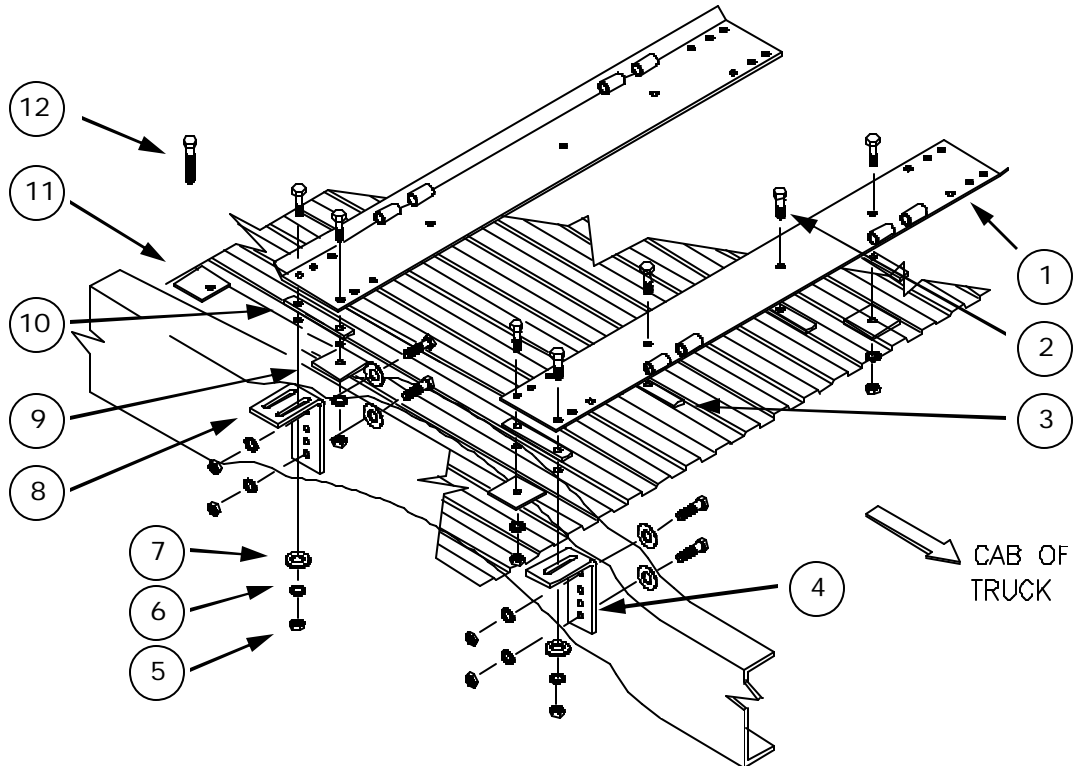

Ref.	Description	Part #	Qty.
1	Base Rails	050404	2
2	1/2" x 2" HHCS Mounting Bolts	98010175	14
3	1/4" x 1" Bottom Bed Shim (one hole)	08070003	6
4	Single Slot UMK Mounting Brkt	08070001	2
5	1/2" - 13 Hex Nuts	98150153	22
6	1/2" Lock Washer	98200142	22
7	1/2" Flat Washer	98250145	22
8	Double Slot UMK Mounting Brkt	08070002	2
9	Center Hole Back-up Plate	05070205	5
10	1/4" x 1" Bottom Bed Shim (two hole)	05070301	4
11	Offset Hole Back-up Plate	05070303	5
12	1/2" x 4" HHCS Mounting Bolts	98010191	4

Hardware Kit (Fasteners, Spacers & Backing Plates) 051202

Installation Kit (Brkt., Rails & Hardware) 0520

Tools Needed For Installation

- | | | |
|---------------------|----------------|---------------------------|
| 1/2" Drill Motor | 3/4" Socket | 1/2" Drive Impact Gun or |
| 1/16" Drill Bit | 1 1/8" Socket | 1/2" Drive Ratchet Wrench |
| 1/2" Drill Bit | Torque Wrench | 3/4" Combination Wrench |
| 3/4" Step Drill Bit | Measuring Tape | Felt Tipped Marker |
| | | Hammer |

Super 5th Preparation

Before the Super 5th is used, the following preparations should be followed:

1. A zerk grease fitting is located on the bottom side of the rocker arm, accessible after installation by tilting the base forward or back, rotating on either set of 3/4" round base rail hinge pins.
Three to five pumps with a grease gun, using an axle type grease, should be adequate lubrication for the grease zerk fitting. All remaining moving parts should be coated with light machine oil.
2. The Plate and it's moving parts should be lubricated with a light lubricant such as WD-40, 3-in-1 oil, or Silicone Spray Lubricant, before each trip or as needed. Be sure the Plate is free of dirt and old oil buildup.

Vehicle Preparation

After blocking the front wheels, place jack stands under the frame so that the rear of the truck is high enough to allow the rear wheels to drop. This will give easy access to the frame area in the rear wheel well.

Remove the spare tire and loosen the heat shield. This will allow easy access to the underside of the truck bed.

General Installation Instructions

Center of Axle Table:

<u>Year</u>	<u>Model</u>	<u>"B" Measurement</u>
1983-2001	Ford 8' Bed (old & New Body Style)	40-1/2"
	133" wb Std. Cab 155" wb Super Cab 168" Crew Cab	
1988-2001	Chevrolet/GMC—8' Bed	41-3/4"
	Tapered Frame Std. Cab Bonus Cab Crew Cab	
1983-1993	Dodge—8' Bed	42-1/4"
	Std. Cab Club Cab Crew Cab	
1994-2001	Dodge—8' Bed	44-1/8"
	Std. Cab Club Cab	

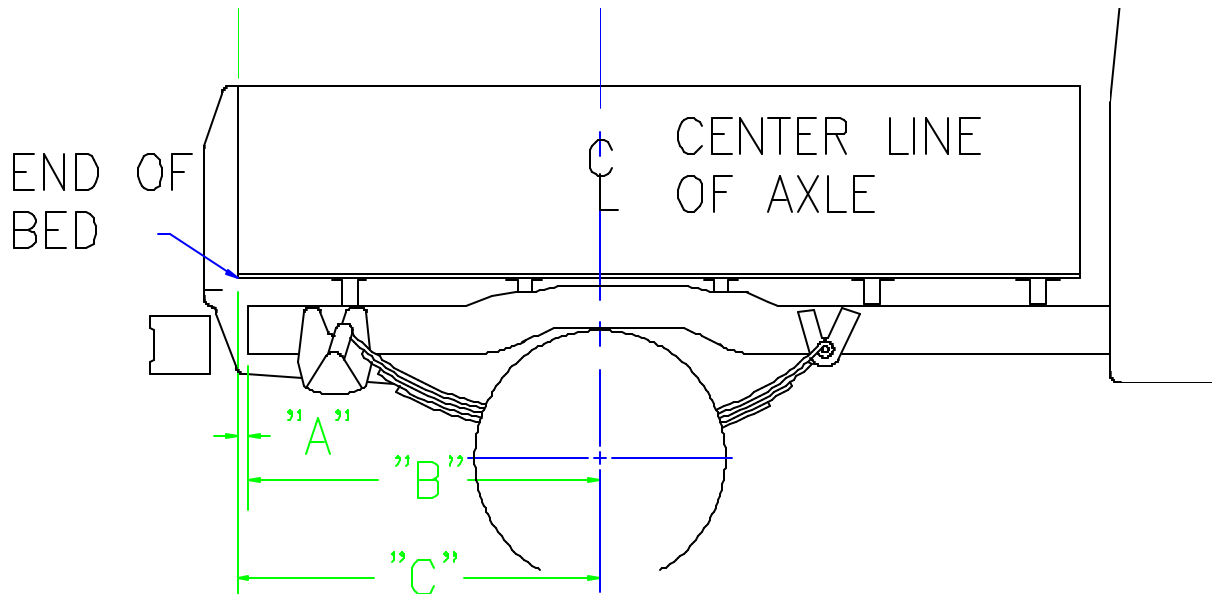

The following installation instructions will give you a general overview of how to position and mount the 5th wheel in the bed of the truck. Location of the 5th wheel in the bed of the truck is the responsibility of the installer and the truck owner.

1. Check the part quantities in the kit, using the parts list on pages 2 and 3.
2. Raise the rear of the truck high enough to allow jack stands to be placed under the rear spring hanger brackets at the rear of the frame. This should be high enough to allow the rear tires to just clear the ground. Block the front tires before lifting the truck so it cannot roll forward or back.
3. To position the 5th wheel over the axle, locate and mark the center of the axle on the side wall of the frame, as well as the bed of the truck.

Location Formula:

Step 1: "A" + "B" = "C" (See Figure Above)

Step 2: "C" + INCHES DESIRED AHEAD OF AXLE (12-1/2") = Location of Row 1

See Figure above, and select from the Center of Axle Table on Page 4, the "B" dimension that corresponds to your model truck. Mark the "B" dimension on the side of the frame.

Dimension "A" is the distance from the end of the frame to the back edge of the bed.

Add dimension "A" to dimension "B" to obtain the measurement from the end of the bed to the center of the axle, dimension "C".

If you centered the holes in row 1 over a line in the bed 12-1/2" ahead of the "center of axle" marks ("C" dimension), the 5th wheel center line would match the center line of the truck axle.

If you want the 5th wheel to be 2" ahead of the axle, center the holes in row 1 over a line in the bed 14-1/2" ahead of the "center of axle" marks ("C" dimension). **PLEASE NOTE THIS IMPORTANT STEP!!!**

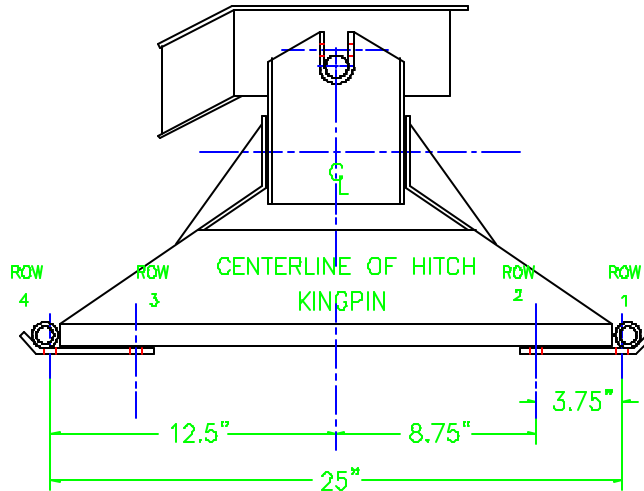

4. Before drilling any holes in the bed, check the bottom of the bed to see what might obstruct the drilling of holes for attaching the mounting brackets to the frame.

In order to know where the hole and bracket placements will be, you must follow the same instructions under the bed as you did on top of the bed to determine the best choice for mounting bracket placement.

Example: Measuring under the truck from the "center of the axle" ("B" dimension) drawn on the side of the frame, mark off the distance of each base rail hole location on the frame. You will then see where the holes will come through the bed in relation to any obstacles. By holding the mounting brackets in line with your marks, you can also see if there will be any obstructions.

NOTE: For a shortcut, make a "bracket template", label the center line on a piece of light weight material (i.e. wood, or aluminum), measure from the center line to where the holes would be located for the mounting brackets, label or notch the hole placement. Placing the template on the frame, match the center line marks, you will be able to see all the hole locations at one time enabling you to see drilling obstructions. See the figure below for hole layout, hole centers may vary + or - 1/16".

SCRIBE MARKS AT THE SHOWN DIMENSIONS
 ALLOWS YOU TO SEE WHERE THE HOLES CAN
 BE DRILLED IN RELATIONSHIP TO THE FRAME
 OR HITCH CENTERLINE.

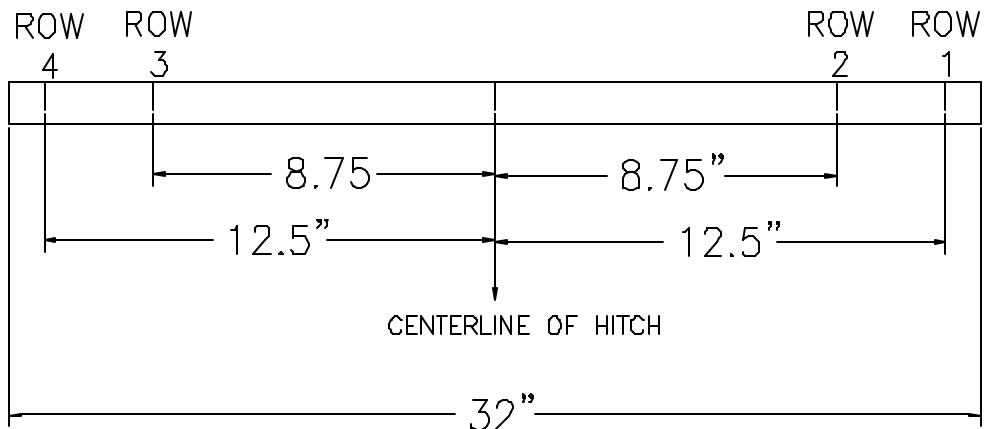

Adjusting the "distance ahead of the axle" you can find the best compromise between the "desired" and "easiest" positioning of the 5th wheel. Once this "compromised" location is found, relocate the 5th wheel on top of the bed using the new "distance ahead of the axle" and adding it to the 14-1/2" measurement.

5. Center the 5th wheel between the wheel wells.
6. Using a 9/16" transfer punch or 9/16" drill bit, mark the holes shown in the Figure below for the respective truck model.

NOTE: The 1988 and newer Chevrolet trucks with a tapered frame may require the use of different holes than those suggested. This is due to the varying width of the frame and may change as the 5th wheel is located at different distances ahead of the axle.

7. Remove the hitch from the bed of the truck. Drill a 9/16" hole through the bed of the truck using the punch marks as a guide. (If you have any doubt that you have located the hitch correctly, drill a very small pilot hole first.)
8. Place the hitch back over the top of the drilled holes after removing the drill shavings from the bed.
9. Install a 1/2" x 2" Mounting Bolt through each hole. Use the optional (longer) 1/2" x 4" Mounting Bolt for holes that may have been drilled through bed crossmembers.
10. See Figure on page 3, fasten the mounting brackets to the bottom of the bed using the 1" x 2" spacers to fill the bed channel (spacers keep the bed channels from collapsing when the bolts are tightened). Install the Mounting Bracket, Flat Washer, Lock Washer and Hex Nut underneath the truck. Clamp the bracket to the side of the frame to be certain that it will remain flush against it.

NOTE: Before drilling, check the inside of the frame to guard against drilling into wiring or lines. Be sure to protect the fuel tank from possible puncture.

11. Drill two 1/2" holes in the frame for each mounting bracket using the holes as a guide. Select holes that will result in the widest spread possible.
12. Torque all bolts to 75 foot pounds except those bolts that pass through bed crossmembers. Bolts passing through the crossmembers should be torqued to 40 foot pounds

